

# CNFT<sup>®</sup>

## OPERATOR'S MANUAL

### FT-3500

船载多系统无线电导航接收机

Multi-system Shipborne Radionavigation Receiver

---

福建飞通通讯科技股份有限公司

[FUJIAN FEITONG COMMUNICATION TECHNOLOGY CO., LTD.]

**Tel/** +86-595-88481988  
**Web/** www.cnfeitong.com  
**Version/** V1.0.0

**地址/** 福建省石狮市高新技术开发区电子信息园飞通科技大厦  
**Addr/** Feitong Technology Building, Electronic Information Park, Hi-Tech  
Industrial Development Zone, Shishi City, Fujian Province, China.

福建飞通通讯科技股份有限公司

FUJIAN FEITONG COMMUNICATION TECHNOLOGY CO., LTD.

# Safety Instruction

**! Danger!**

- If any object falls into the device or water splashes onto it, immediately turn off the power at the distribution panel.  
(Continued use may cause fire or electric shock)
- If the device emits smoke or catches fire, immediately turn off the power at the distribution panel.  
(Continued use may cause fire or electric shock)
- If the device operates abnormally, immediately turn off the power at the distribution panel.  
(Continued use may cause fire or electric shock; it is recommended to contact the agent/ distributor for consultation)

**! Warning!**

- Be sure to turn off the power at the distribution panel before starting installation.  
(Power-on during installation may cause fire or electric shock)
- Use only the specified power cable.  
(Using other cables may cause fire or electric shock)
- Do not install the device in locations where it may be exposed to rain or splashing water.  
(Water entering the device may cause fire or electric shock)

**! Warning!**

- Do not perform operations inside the device unless fully familiar with electrical circuits.
- Hazardous voltages exist inside the device that may cause electric shock.

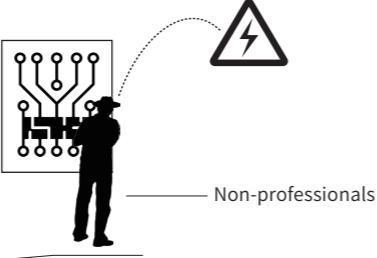

Non-professionals

- Before starting installation, turn off the power at the main distribution panel. Post a sign near the switch indicating that the power should not be turned on during installation. Failure to turn off or accidental activation of power during installation may result in fire, electric shock, or serious injury.

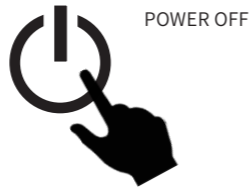

POWER OFF

**! Caution!**

- Ensure the power supply voltage is compatible with the device's rated voltage. Incorrect power connection may cause fire or equipment damage. The rated voltage is indicated on the label on the back of the display unit.
- Handle the grounding copper strap with care; its edges may injure your hands.
- Maintain a minimum compass safe distance of 70MM.
- Grounding the device: Ungrounded equipment may emit or receive electromagnetic interference, or cause electric shock.



# CONTENTS

- Safety Tips.....01
- PrefaceMain.....03
- Technical Specifications.....03
- Installation Instructions.....04-07
  - Connection Diagram and Interface Definitions.....04
  - Desktop Mounting.....05
  - Overhead Mounting.....05
  - Embedded Mounting.....06
  - GNSS Antenna.....07
- Overall.....08-09
  - Main Unit.....08
  - Front View.....09
  - Rear View.....09
- MAIN FUNCTION.....10-15
  - Power On/Off.....10
  - Brightness and Display Mode.....10
  - Main Interface Switching.....10
  - Parameter Settings.....12
  - System Settings.....13
  - Navigation List.....13
  - Alert Information.....14
  - Self-Test.....15
- System & Interfaces.....16-20
- Updates and Maintenance.....21
- 操作说明中文版.....22(起)

## PREFACE

Thank you for choosing our product, Model: FT-3500, Name: Multi-System Shipborne Radio-Navigation Receiver. The product includes the main unit and accessories provided as standard; please refer to the Packing List for details. Before installing and using this product, please carefully read the User Manual to prevent damage caused by improper operation or lack of professional handling, which may lead to equipment failure or personal safety risks. Our company does not assume any liability for consequences arising from improper use.

※ **Note: If product upgrades or updates result in discrepancies between the User Manual and actual device operation, the device specifications shall prevail.**

## MAIN TECHNICAL SPECIFICATIONS

Project Name	Technical Specifications
Frequency Range	GPS: L1(1575.42MHz) ; BDS: B1(1561.098MHz)
Positioning Accuracy	2.5≤ (95%)
Acquisition Sensitivity	≤-130dBm
Tracking Sensitivity	≤-140dBm
Time to First Fix (TTFF)	≤30S
Position Update Interval	≤1s for conventional vessels, ≤0.5s for high-speed vessels
SOG Accuracy	≤2% or 0.2 knots
COG Accuracy	≤±3° (1kt < S ≤ 17kt); ≤±1° (S > 17kt)
Display Unit	7"
Compass Safe Distance	70cm
Protection Rating	IP54
Antenna Impedance	50Ω
Power Supply	DC 13.8V(12.4V-18V)

## INSTALLATION INSTRUCTIONS

### ■ Connection Diagram and Interface Definitions

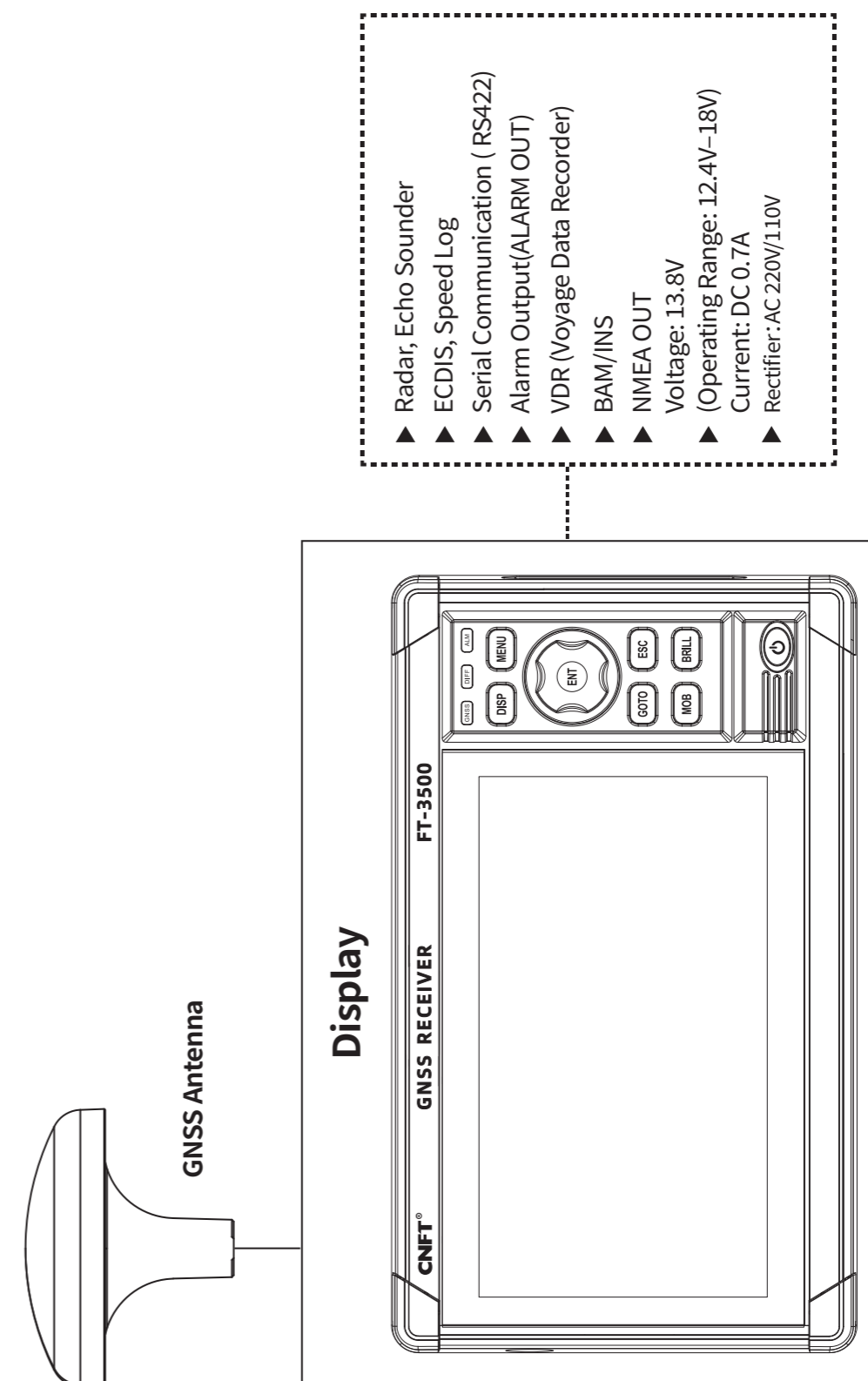

Desktop Mounting

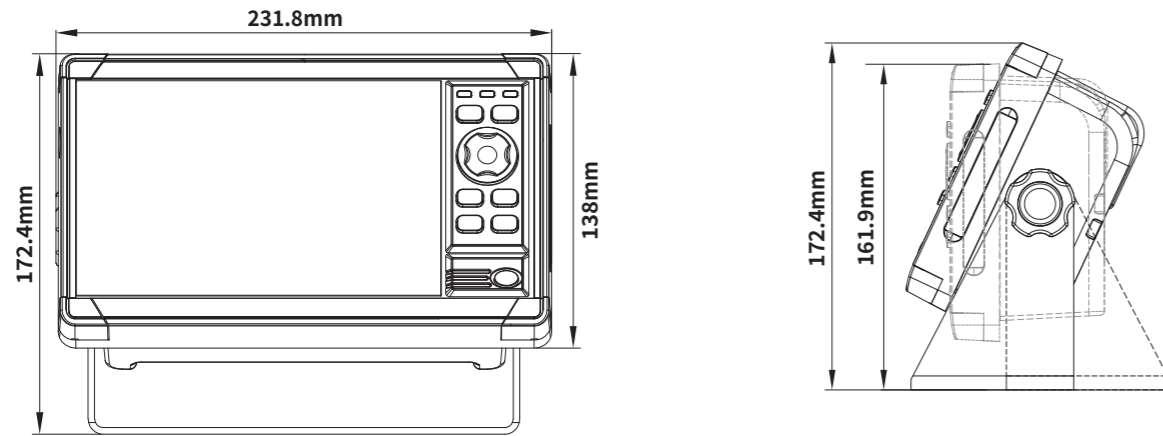

Overhead Mounting

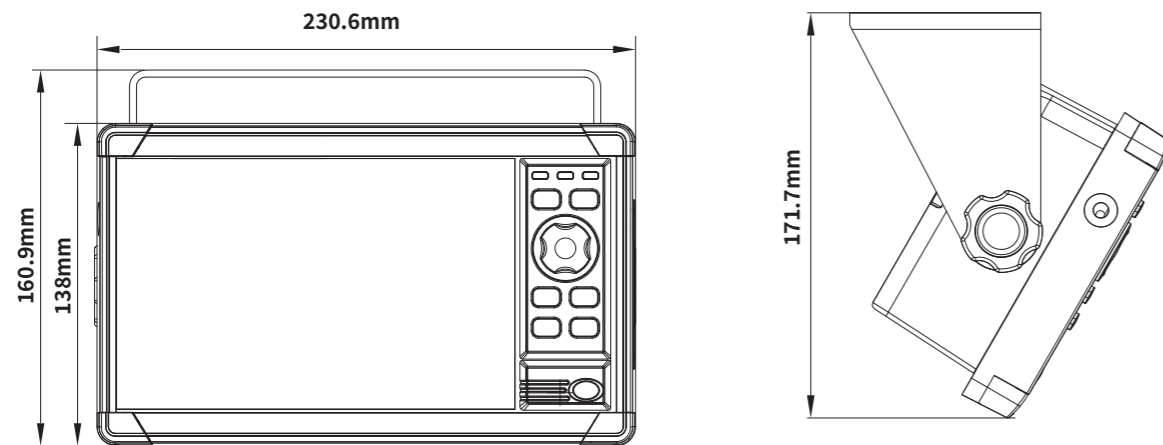

Embedded Mounting

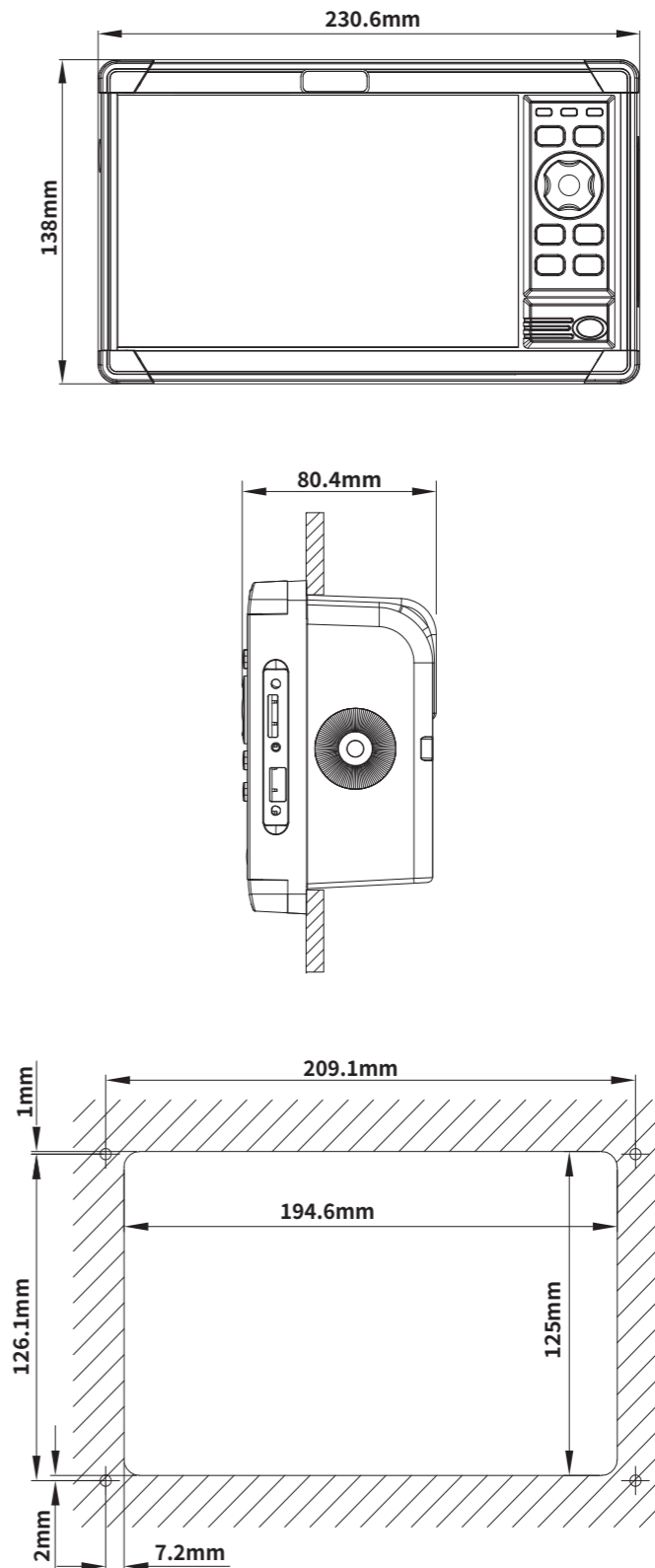

### GNSS Antenna

Positioning signals cannot be received indoors; the positioning antenna must be installed in an open, unobstructed outdoor location.

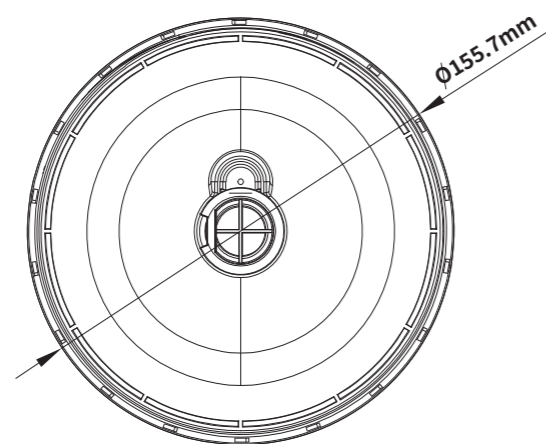
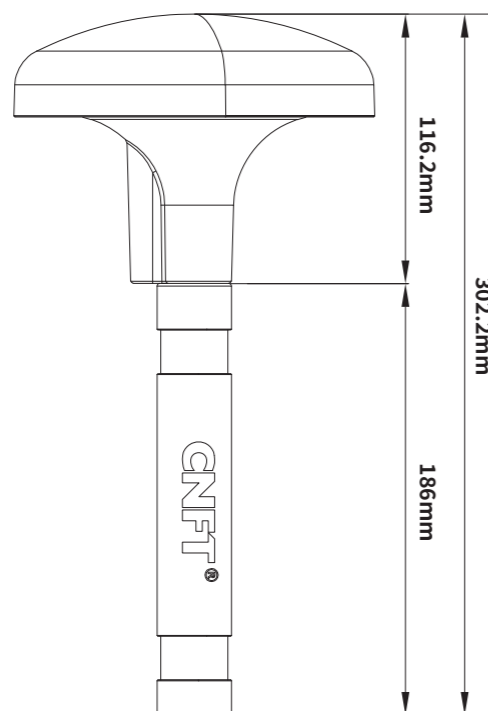

## OVERALL

### ■ Main Unit

#### Panel Description

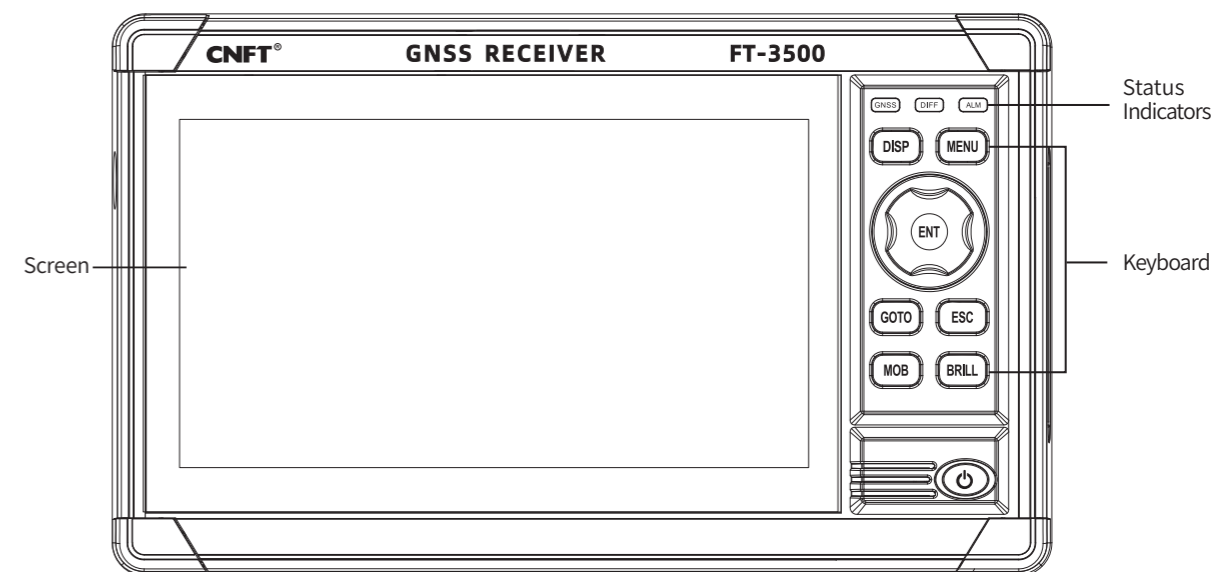

#### 键盘：

[▲][▼][◀][▶]	Arrow keys: Used to navigate and select items in the menu.
图面	Display mode switch: Quickly switch between different main interfaces.
菜单	Menu wake-up: Enter the system settings menu.
确认	Confirm key: Used to confirm selections and execute operations.
导航	Quick jump: Quickly locate a specified waypoint in the waypoint list.
返回	Cancel key: Used to cancel operations or exit the main menu.
MOB	Man Overboard: Quickly record the current ship position.
亮度	Brightness adjustment/lighting conditions: Adjust the screen and button brightness, switch display modes.
⏻	Power key: Used to turn the machine on and off.

■ Front View

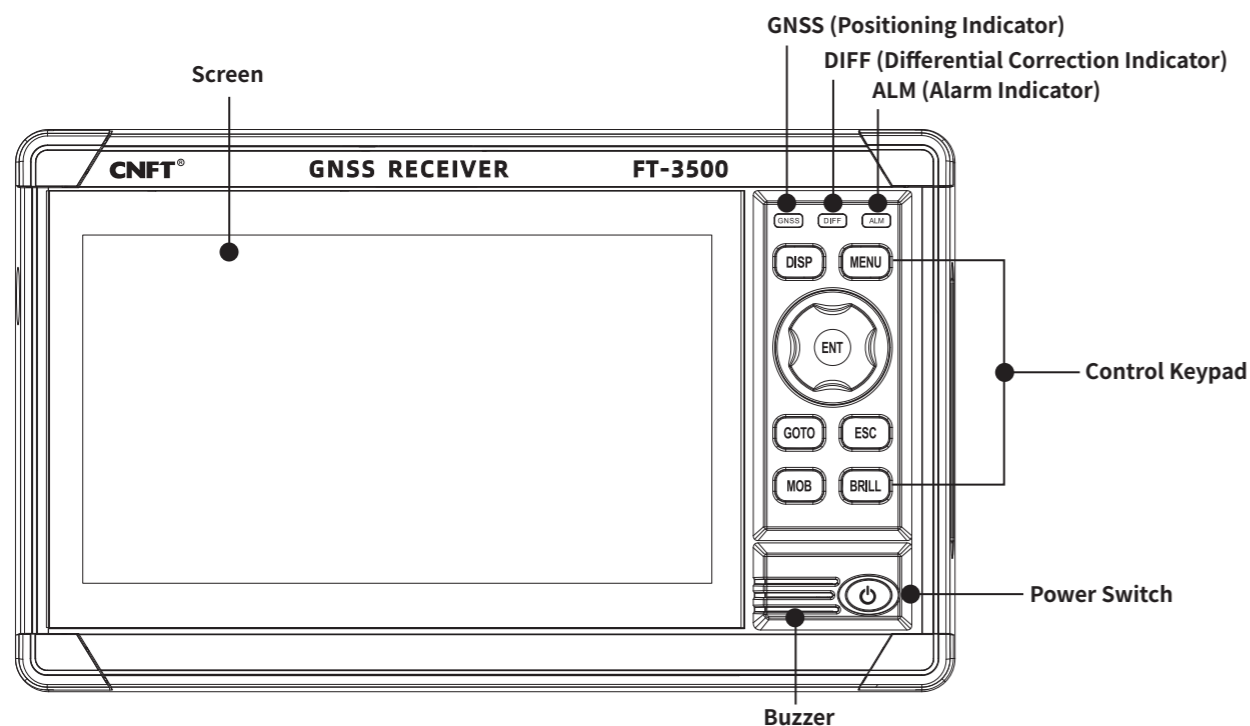

■ Rear View

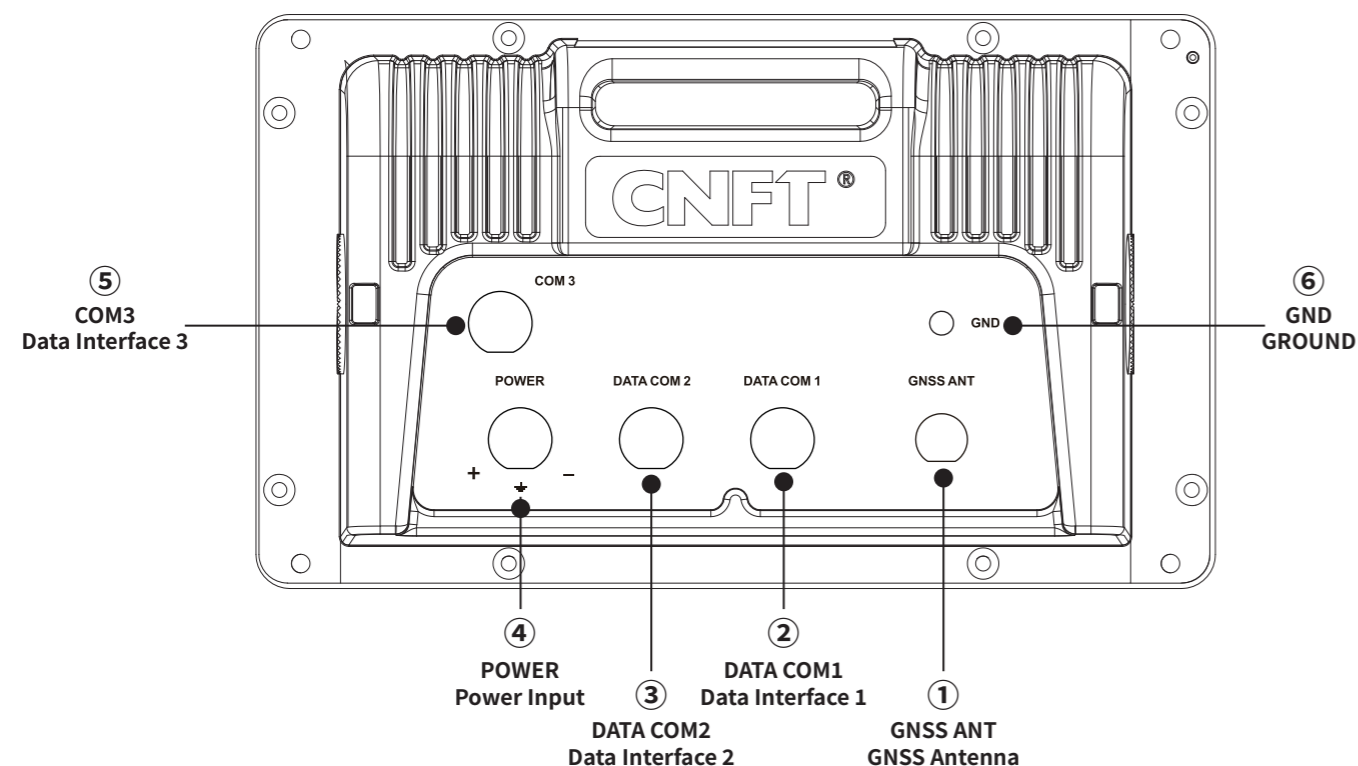

## MAIN FUNCTION

### ◆Power On/Off :

Press the "⏻" power key to turn on the device.

To turn off the device, either press and hold the "⏻" power key for 3 seconds or press the "⏻" power key and then press the [ENT] key.

### ◆Brightness and Display Mode

Users can adjust the device display according to their needs, supporting brightness, button backlight, and display mode selection adjustments.

1. Press the [BRILL] key to enter the brightness adjustment page.
2. Use the [◀] [▶] keys or the touchscreen to adjust the screen brightness.
3. Use the [▲] [▼] keys or the touchscreen to adjust the button brightness.
4. Use the touchscreen to directly switch display modes (Auto, User, Day, Cloudy, Night).
5. Press the [ENT] key to save the settings.

### ◆Main Interface Switching

Press the [DISP] key to quickly switch between the main interfaces, including the positioning interface, ephemeris information interface, speed and course interface, and 3D navigation interface.

Positioning Interface: Displays current location, speed, course, and other information.

RAIM	PDOP	A. LEVEL	DGNSS	STATUS	2024/12/02
UNSAFE	0.8	10m	LOST	⚠	09:02:13 <small>LOC</small>
WGS-84					
<b>N 24°41.2070</b>					
<b>E118°41.9010</b>					
FIX		SOG		COG (T)	
GN-3D		0.00 <sub>kt</sub>		0.0°	

Press the [DISP] key to switch to the ephemeris information interface; It displays the satellite connection status and signal strength, as well as information on positioning mode, position accuracy, horizontal accuracy, and vertical accuracy.

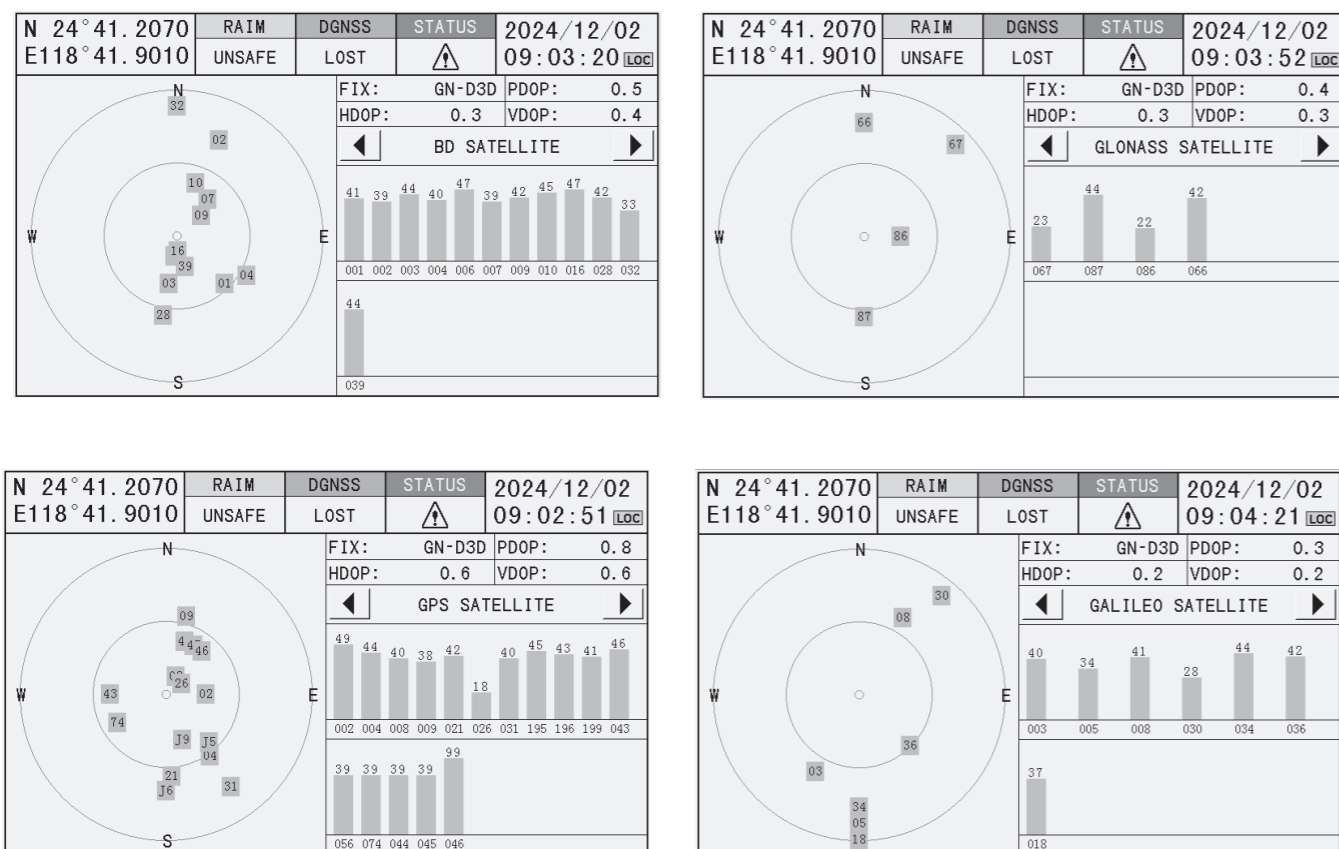

Press the [DISP] key to switch to the speed and course interface, which displays real-time speed and course changes.

Press the [DISP] key to switch to the 3D navigation interface, which provides a three-dimensional view, intuitively displaying the navigation trajectory. You can view information such as estimated arrival time, direction, distance, and target. You can adjust the range and perspective using the touchscreen or arrow keys.

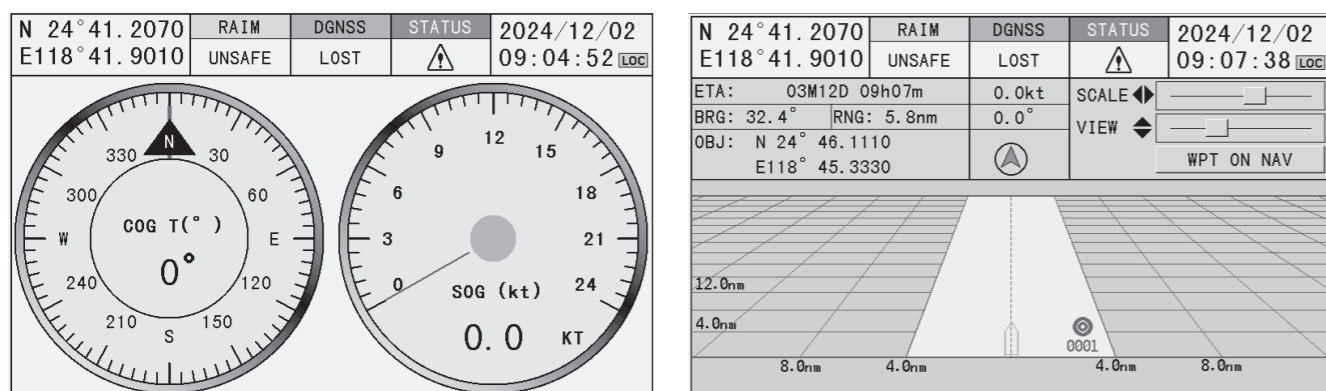

### ◆Parameter Settings

Setting Internal Parameters of the Device, Including Communication and Positioning Parameters:

1. Press the [MENU] key and select "NMEA SET" to open the parameter settings dialog box.
2. Use the [▲] [▼] keys to select one of the options in "Machine Setting," such as "NMEA Mode, Baud Rate, Frequency, POS Mode, DGNSS and Accuracy Level.
3. Press the [ENT] key to set the relevant parameters.

For example, NMEA Mode SET: Set the GNSS output content of the DATACOM2 port, such as RMC, GGA, etc.

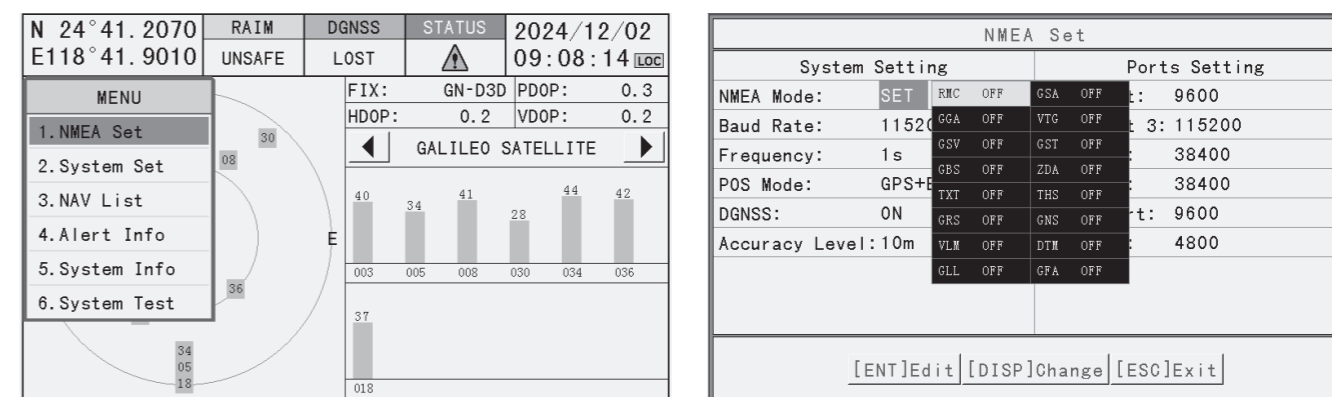

Press the [▶] key to select one of the options in "Port Setting," such as "GNSS Port," "Data Port," "INS Port," "AIS Port," "DGNSS Port," or "Heading Port." Then press the [ENT] key to set the relevant parameters.

For example, GNSS port parameter settings: Set the baud rate and output data settings.

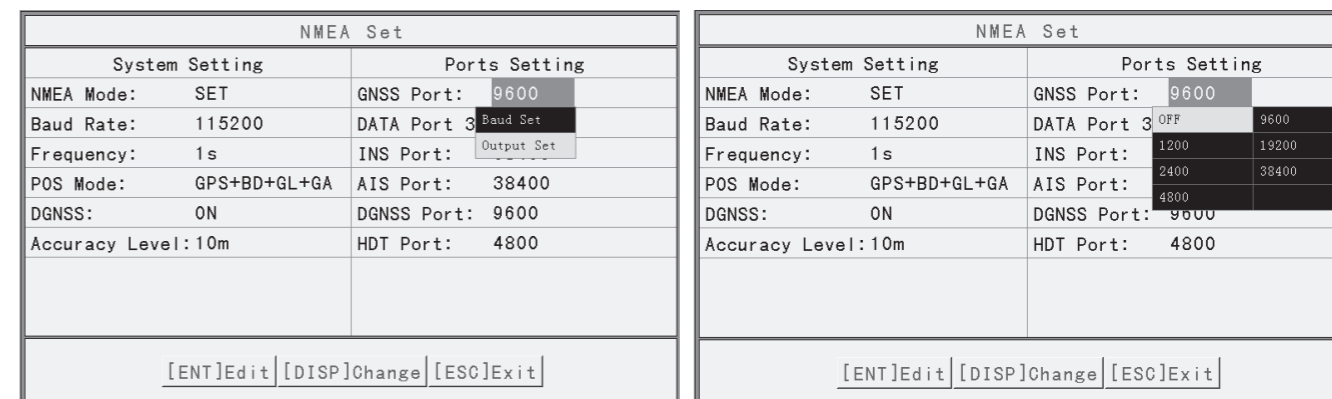

### ◆System Settings

System Settings:

1. Set system-level parameters such as system language, time zone, and distance units.
2. Press the [Menu] key and select "System Set" to open the function settings dialog box.
3. Use the [▲] [▼] keys to select the function you want to modify, then use the [◀] [▶] keys to change the settings.

For example, to select "Language," use the [◀] [▶] keys to choose between "Simplified/Traditional/English."

4. After making changes, press the [ENT] key to select "Save." If you do not want to save, select "ESC"
5. Press the [DISP] key or tap "Restore Factory Settings" on the touchscreen, then select "ENT" to restore factory settings.

RAIM	PDOP	A. LEVEL	DGNSS	STATUS	2024/12/02
UNSAFE	0.8	10m	LOST	⚠	09:16:13
MENU					
1. NMEA Set					
2. System Set					
3. NAV List					
4. Alert Info					
5. System Info					
6. System Test					
4°41.2070					
8°41.9010					
GN-3D					
SOG 0.00 <sub>kt</sub>					
COG (T) 0.0°					

System Set			
Language:	EN	Warn Mode:	New
Time Zone:	+08:00	Warn Reach:	1.0nm
Distance Unit:	nm	PASS Set:	Set
Direction:	TN		
MAG VAR:	AUTO		
SOG Filtering:	20		
COG Filtering:	10		
Button VOL:	02		
Warn VOL:	Low		
Prompt VOL:	06		
[L]Modify [R]Modify [ENT]ENT [DISP]Init [ESC]Exit			

### ◆Navigation List

◇Waypoint List

Manage and operate the waypoint list, including editing and navigation functions.

1. Press the [Menu] key and select "WPT List"
2. Press the [▶] key to select the waypoint list, then press the [ENT] key to enter the "Waypoint List" interface.
3. Select a waypoint, then press the [Menu] key to perform operations such as creating, editing, deleting (single or all), sorting, displaying, navigating, and stopping navigation.

This feature provides users with a flexible waypoint management solution.

RAIM	PDOP	A. LEVEL	DGNSS	STATUS	2024/12/02
UNSAFE	0.8	10m	LOST	⚠	09:18:05
MENU					
1. NMEA Set					
2. System Set					
3. NAV List					
4. Alert Info					
5. System Info					
6. System Test					
4°41.2070					
1.9010					
GN-3D					
SOG 0.00 <sub>kt</sub>					
COG (T) 0.0°					

WPT List [0002/0001]					
NO.	NAME	FUNC MENU	LON	LOCK	
0001	Num0000	NEW	140 E118° 43.8530	×	
0002	Num0001	EDIT	10 E118° 45.3330	×	
		DEL			
		DEL ALL			
		SORT			
		LOCK			
		NAV			
		STOP NAV			
[L]Page [R]Page [MENU]Func [ESC]Exit					

◇ MOB List

Manage and operate the MOB list.

1. Press the [MENU] key and select "Nav List."
2. Press the [▶] key to select the MOB list, then press the [ENT] key to enter the "MOB List" interface.
3. Select an entry, then press the [MENU] key to perform operations such as locking, deleting (single or all), navigating, and stopping navigation.

This feature ensures users have the ability to track and control dynamic targets.

RAIM	PDOP	A. LEVEL	DGNSS	STATUS	2024/12/02
UNSAFE	0.8	10m	LOST	⚠	09:20:46
MENU					
1. NMEA Set					
2. System Set					
3. NAV List					
4. Alert Info					
5. System Info					
6. System Test					
4°41.2070					
1.9010					
GN-3D					
SOG 0.00 <sub>kt</sub>					
COG (T) 0.0°					

MOB List [002/001]					
NO.	TIME	FUNC MENU	LON	LOCK	
0001	2024-09-20 07:24	LOCK	07 E118° 41.901	×	
0002	2024-09-27 09:02	DEL	07 E118° 42.901	✓	
		DEL ALL			
		NAV			
		STOP NAV			
[L]Page [R]Page [MENU]Func [ESC]Exit					

### ◆Alert Information

◇Alert List

1. Press the [MENU] key and select "Alert Info"
2. Press the [▶] key to select the Alert List, then press the [ENT] key to enter the "Alert List" interface to view Alert information.
3. Select an entry from the list, then press the [DISP] key or tap "View" on the touchscreen to see "Detailed Information."

The list provides comprehensive details on the Alert status, ID, occurrence time, type, and cause, enabling users to quickly identify and respond to urgent issues. Press the [ENT] key to acknowledge the Alert information and promptly intervene.

RAIM	PDOP	A. LEVEL	DGNSS	STATUS	2024/12/02
UNSAFE	0.8	10m	LOST	⚠	09:21:50
MENU					
1. NMEA Set					
2. System Set					
3. NAV List					
4. Alert Info					
5. System Info					
6. System Test					
4°41.2070					
1.9010					
GN-3D					
SOG 0.00 <sub>kt</sub>					
COG (T) 0.0°					

Alert List [001/001]					
Status	ID	Start Time(UTC)	Type	Cause	
NO ACK	3012	2024-09-25 08:28:37	Caution	GNSS:Differentia...	
[ENT]ACK [DISP]View [ESC]Exit					

◇ Alert Log

1. Press the [MENU] key and select "Alert Log."
2. Press the [▶] key to select the Alert log, then press the [ENT] key to enter the "Alert Log" interface.
3. Select an entry from the list, then press the [DISP] key or tap "View" on the touchscreen to see "Detailed Information."

This system records all warning events that occurred during the device's operation, regardless of whether these warnings have been resolved. The log contains detailed warning information such as status, ID, time, type, and cause, making it an important resource for analyzing historical data, evaluating system performance, and preventing issues. You can easily browse historical warning information using the left and right keys, providing strong support for problem tracking and system optimization.

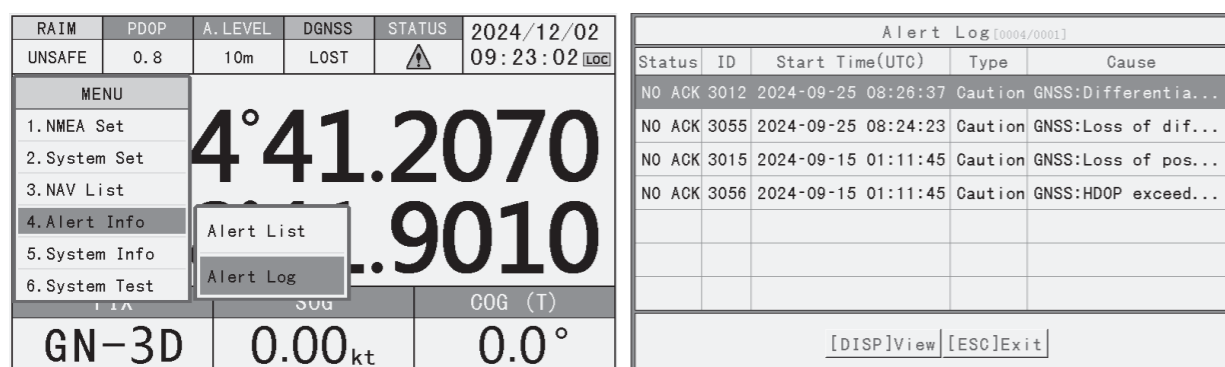

◆ Self-Test

1. Press the [MENU] key and select "System Test."
2. This function visually presents the internal detection process of the device. Through the self-test display, users can intuitively confirm whether the working status of each component in the system is normal, ensuring the stability and reliability of the device's operation.
3. Additionally, users can use the self-test interface to verify the data input status of each port and whether the input statements are correctly recognized by the device, providing great convenience for daily maintenance and troubleshooting.

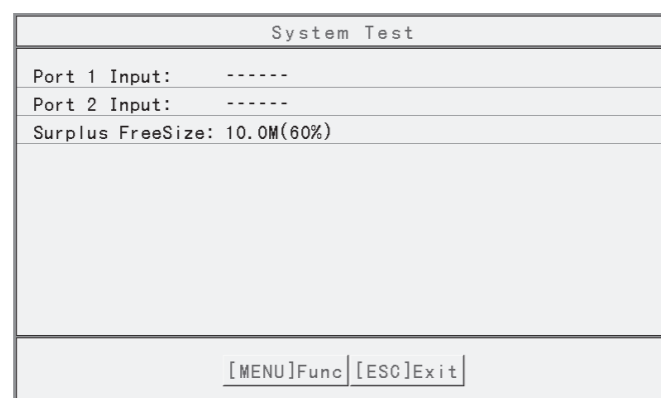

# System & Interfaces

## ■ Front View

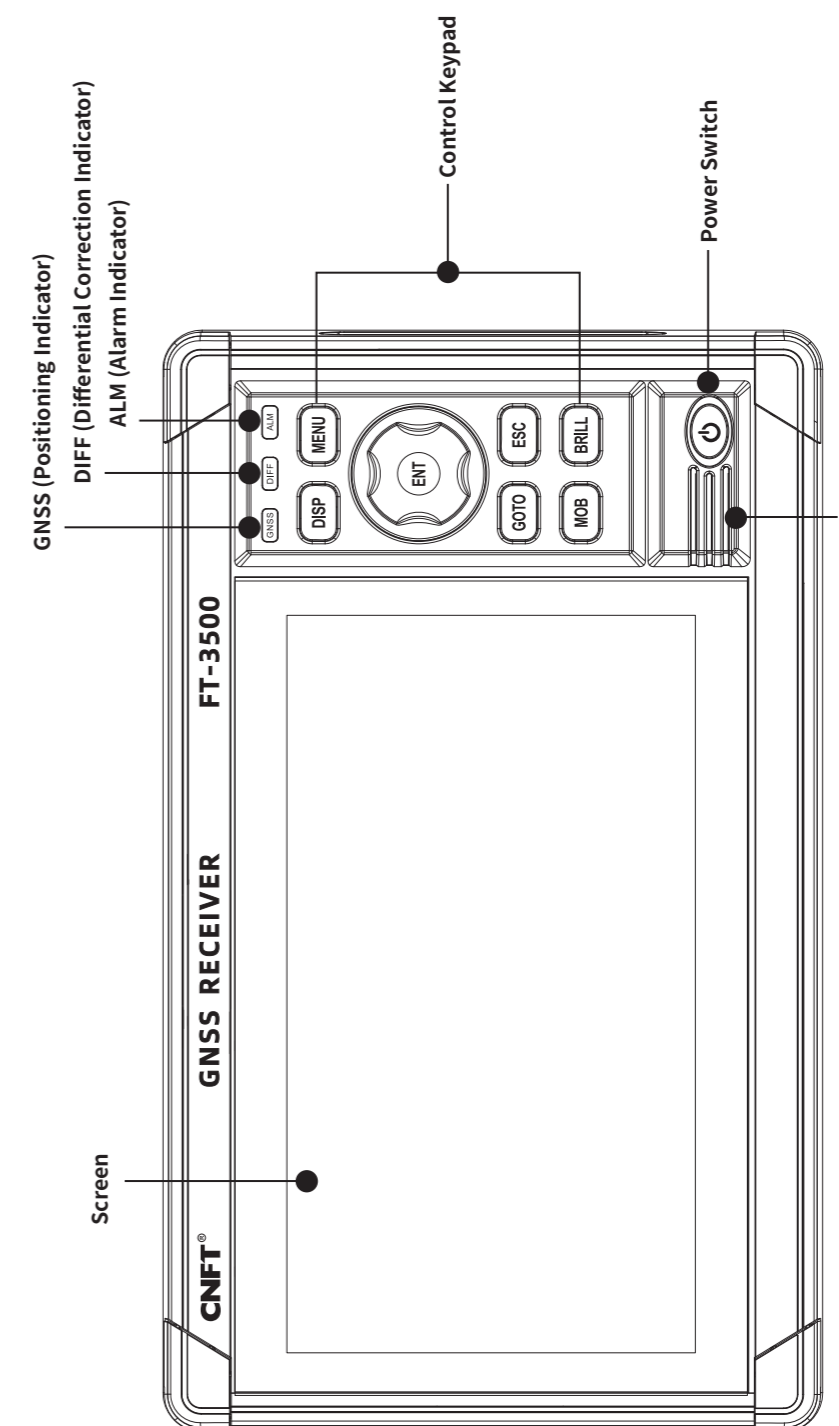

■ Rear View

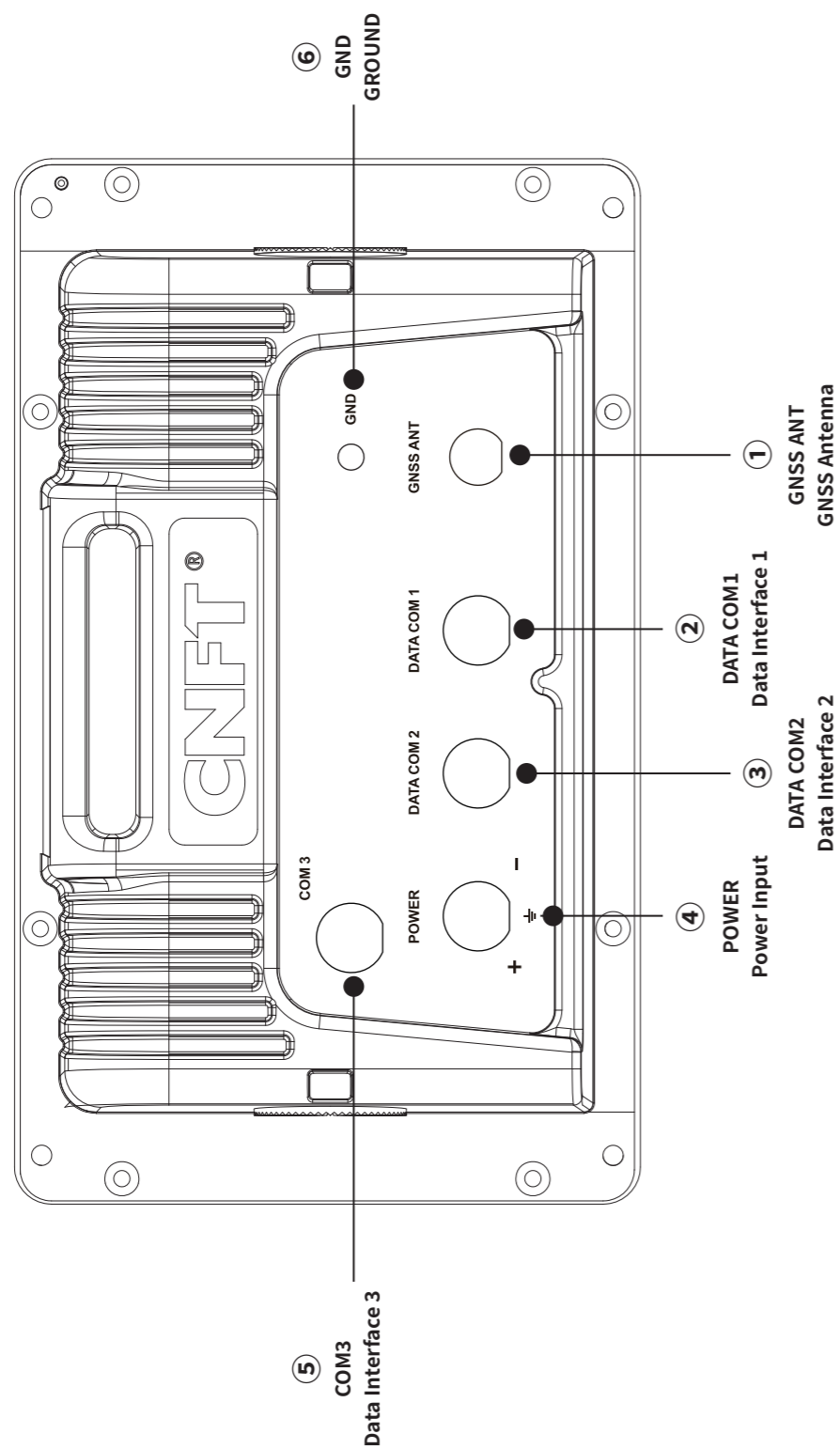

■ Rear View

- ① GNSS ANT (External GNSS Antenna Connector)
- ② DATA COM1 (Data Interface Port 1)

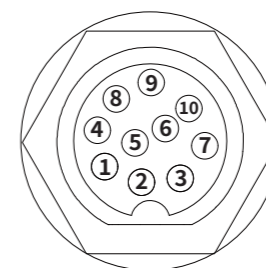

NO.	Definition		Function
1	INS/BAM	422 TXD-	Management System Output (-)
4		422 TXD+	Management System Output (+)
2		422 RXD-	Management System Input (-)
3		422 RXD+	Management System Input (+)
5	GNSS OUT	422 TXD-	GNSS Output (-)
8		422 TXD+	GNSS Output (+)
6	DGSS IN	422 RXD-	Differential Data Input (-)
7		422 RXD+	Differential Data Input (+)
9	ALARM	COMMON	Alarm Output Common Terminal
10		N.O	Alarm Output Normally Open Contact

③ DATA COM2 (Data Interface Port 2)

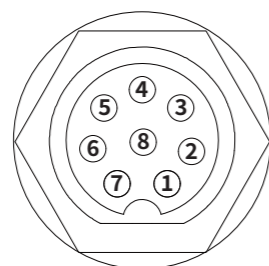

NO.	Definition	Function
1	CAN	CAN_H CAN Communication Interface_H
2		CAN_L CAN Communication Interface_L
3	GNSS OUT	422 RXD+ GNSS Input (+)
4		422 RXD- GNSS Input (-)
5	EXT.AIS	422 TXD+ AIS Output (+)
6		422 TXD- AIS Output (-)
7	EXT.HDG	422 RXD+ Heading Input (+)
8		422 RXD- Heading Input (-)

④ POWER (Power Input Terminal: 13.8V [Range: 10.8V–15.6V])

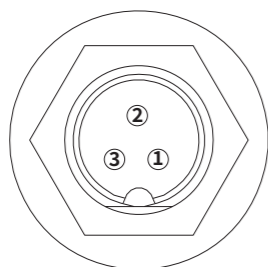

- 1: Power Input Negative (-)
- 2: GND — Ground Terminal
- 3: Power Input Positive (+)

⑤ COM3 (Expansion Interface Port 3)

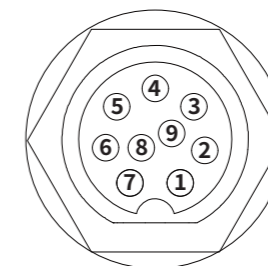

NO.	Definition	Function
1	VDD	DC 12V
2	GND	Ground
3	422 RXD+	RS422 Serial Input (-)
4	422 RXD-	RS422 Serial Input (+)
5	VDD	DC 12V
6	422 TXD+	RS422 Serial Output (+)
7	422 TXD-	RS422 Serial Output (-)
8	GND	Ground
9	GND	Ground

⑥ GND (System Ground Terminal)

## UPDATES AND MAINTENANCE

### ■ Clean

If the machine is dirty or dusty, wipe it with a soft, dry cloth.

Avoid using chemicals or alcohol, as they may damage the surface of the machine.

### ■ Replacing the Fuse

If the fuse is blown or the machine stops working, identify the cause and, if possible, replace the fuse. The fuse is located in the FUSE box.

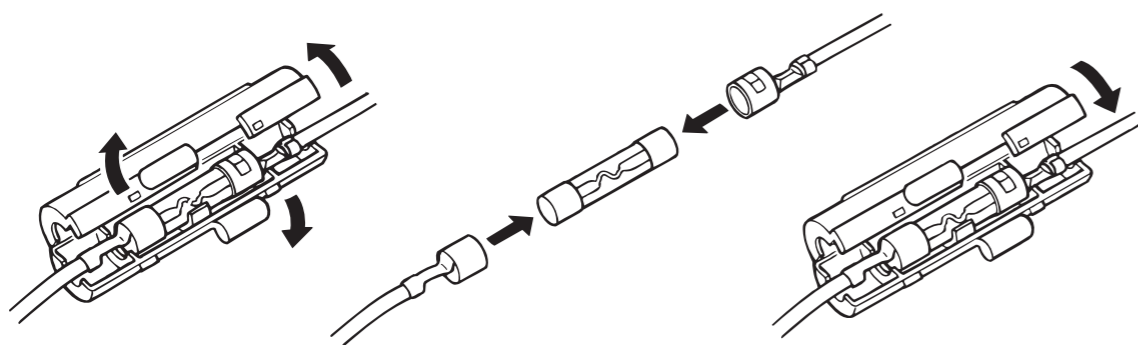

### ■ Troubleshooting

Power Issues	
Power on failure	Check if the power connector is securely connected. Check if the positive and negative terminals are reversed. Check if the fuse is damaged. If the issue persists, do not attempt to inspect the internal components of the device yourself.
Reception Issues	
Reception Failure	Check whether the distance to the transmitter exceeds 400 nautical miles. Check whether the antenna cable is short-circuited or open-circuited. If unable to receive message, check for strong signal interface, such as radar, radio stations, or other radio transmitters. If unable to receive message (except for ABDL), check the reception settings.
Display Issues	
Unreadable Characters	Check and adjust the contrast.
Character Breakage	Contact after-sales service.

## 安全提示

### ⚠ 危险!

- 若有物品掉入设备或水溅入设备, 立即关闭配电板电源。(继续使用可能引发火灾或触电)
- 若设备冒烟或起火, 立即关闭配电板电源。(继续使用可能引发火灾或触电)
- 若设备运行异常, 立即关闭配电板电源。(继续使用可能引发火灾或触电, 建议联系代理商 / 经销商咨询)

### ⚠ 警告!

- 开始安装前, 务必关闭配电板电源。板电源。(安装过程中通电可能引发火灾或触电)
- 仅使用指定电源线。(使用其他电缆可能引发火灾或触电)
- 请勿在设备可能被雨水或溅水打湿的位置安装。(水进入设备内部可能引发火灾或触电)

### ⚠ 警告!

- 除非完全熟悉电气电路, 否则请勿在设备内部作业。
- 设备内部存在可能导致触电的危险电压。

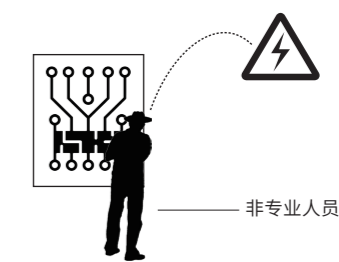

- 开始安装前, 请关闭主配电板上的电源。在开关附近张贴标志, 表明设备安装期间不应打开电源。如果设备安装期间电源未关闭或接通, 可能会导致火灾、触电或重伤。



### ⚠ 注意!

- 确认电源电压与设备的额定电压兼容。连接错误的电源可能会导致火灾或设备损坏。额定电压显示在显示单元背面的标签上。
- 小心使用接地铜带, 其边缘可能会伤到您的手。
- 请保持以下罗盘安全距离 70MM 以上。
- 接地设备: 未接地的设备可能会发出或收电磁干扰, 或导致触电。



## 目录

安全提示.....	22
前 言.....	24
主要技术指标.....	24
安装说明.....	25-28
■系统连接图说明.....	25
■显示单元支架类型.....	26
■显示单元吊顶类型.....	26
■嵌入式类型.....	27
■GNSS天线单元.....	28
整机说明.....	29-30
■主机部分.....	29
■显示单元前视图说明.....	30
■显示单元后视图说明.....	30
主要功能操作说明.....	31-36
■开关机操作.....	31
■亮度和显示模式调节.....	31
■主界面切换操作.....	31
■参数设置.....	33
■系统设置.....	34
■导航列表.....	34
■警告信息.....	35
■自检信息.....	36
系统接口规格说明.....	37-41
更新与维护.....	42

## 前言

感谢您选用本公司研制的产品,型号:FT-3500 名称:船载多系统无线电导航接收机。产品包括主机以及随机配置附件,请参看产品《装箱清单表》。在安装使用产品前,请务必仔细阅读《操作手册》,避免人员不专业、错误操作引起设备损坏或人身安全,本公司不承担由此引起的一切后果责任。

※注:若产品升级更新导致《操作手册》与设备实际操作使用不一致,请以设备为准。

## 主要技术指标

项目名称	技术参数
频率范围	GPS: L1(1575.42MHz) ; BDS: B1(1561.098MHz)
定位精度	2.5≤(95%)
捕获灵敏度	≤-130dBm
跟踪灵敏度	≤-140dBm
首次定位时间	≤30S
位置更新时间	常规船舶≤1S, 高速船≤0.5S
SOG精度	≤2%或0.2节
COG精度	≤±3°(1节<S≤17节); ≤17±1°(17节>)
显示单元	7寸
罗经安全距离	70cm
防护等级	IP54
天线阻抗	50Ω
电源	DC 13.8V(12.4V-18V)

# 安装说明

## ■ 系统连接图说明

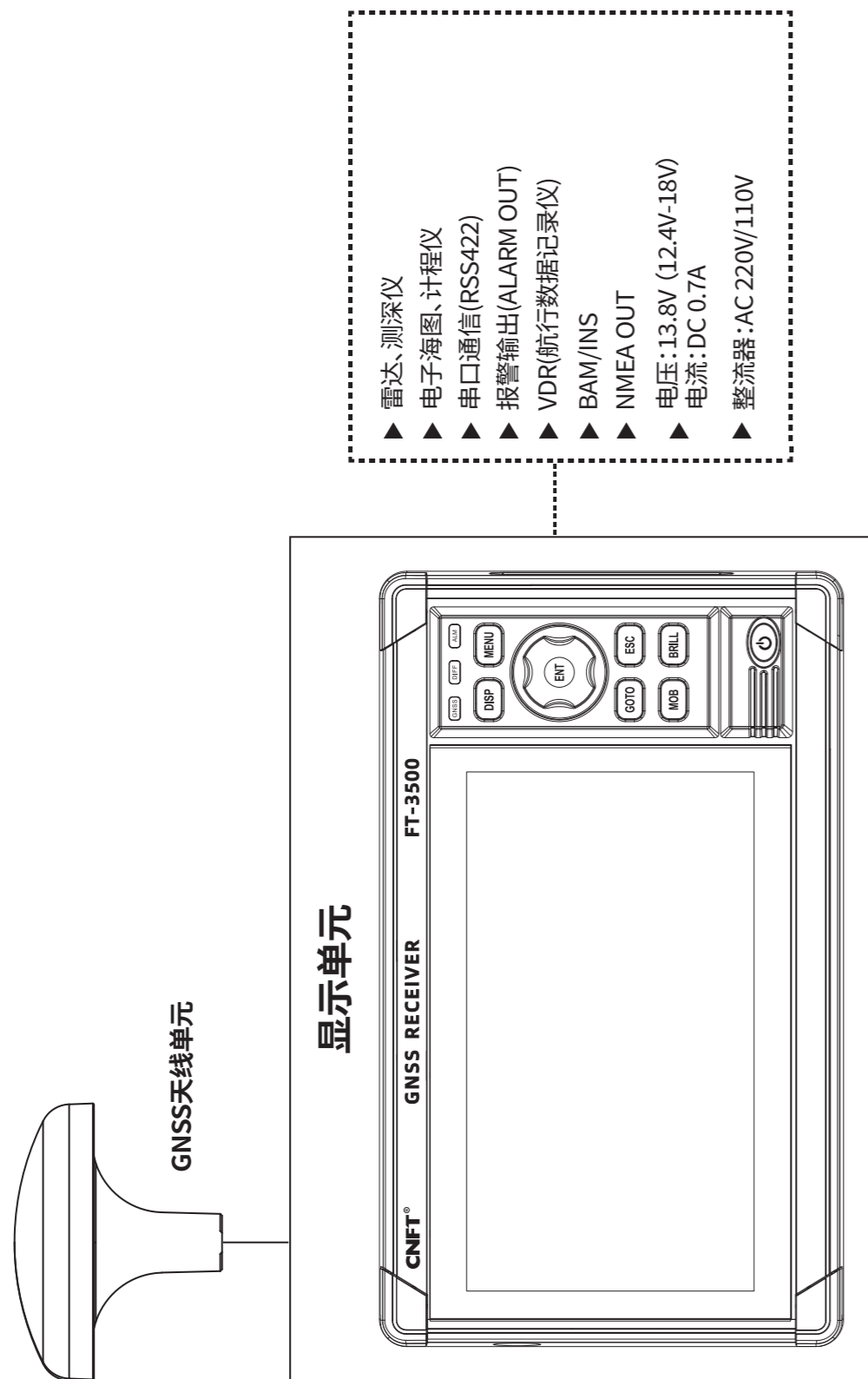

## 显示单元支架类型

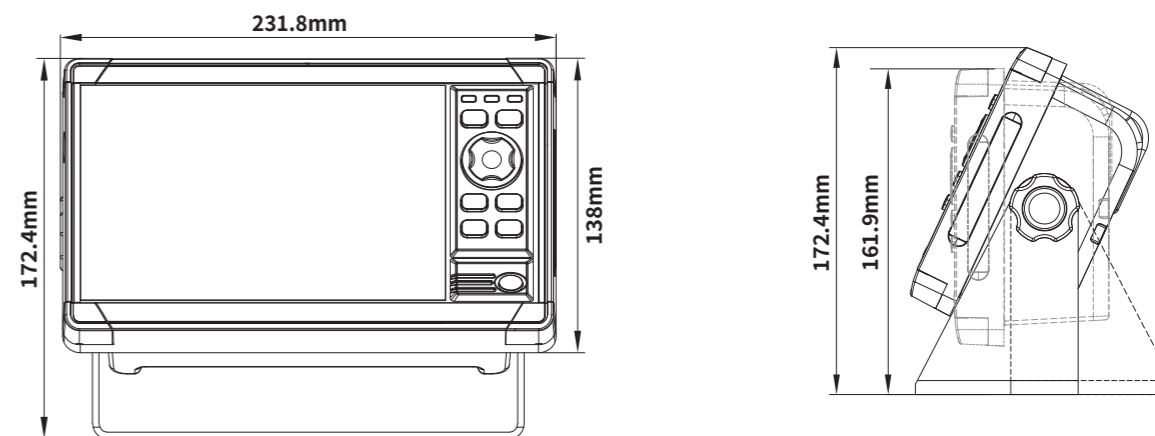

## 显示单元吊顶类型

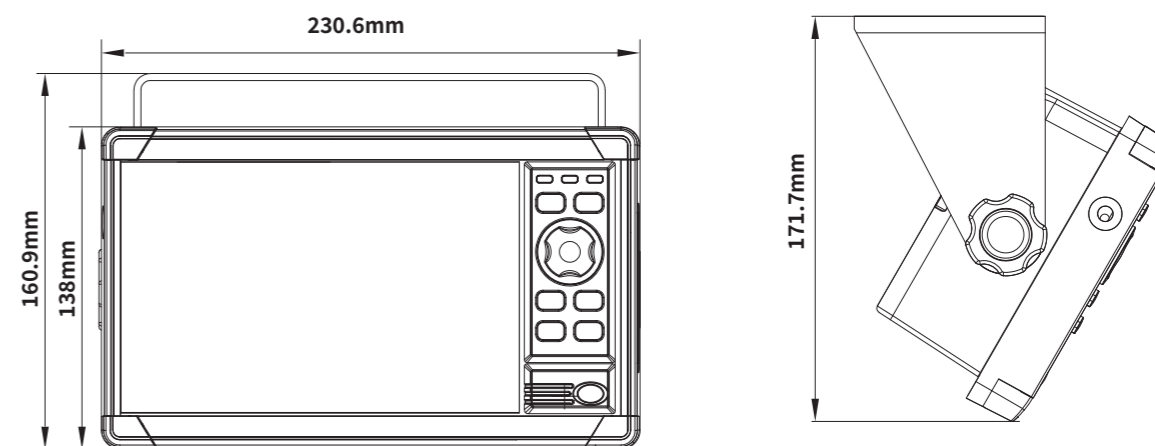

嵌入式类型

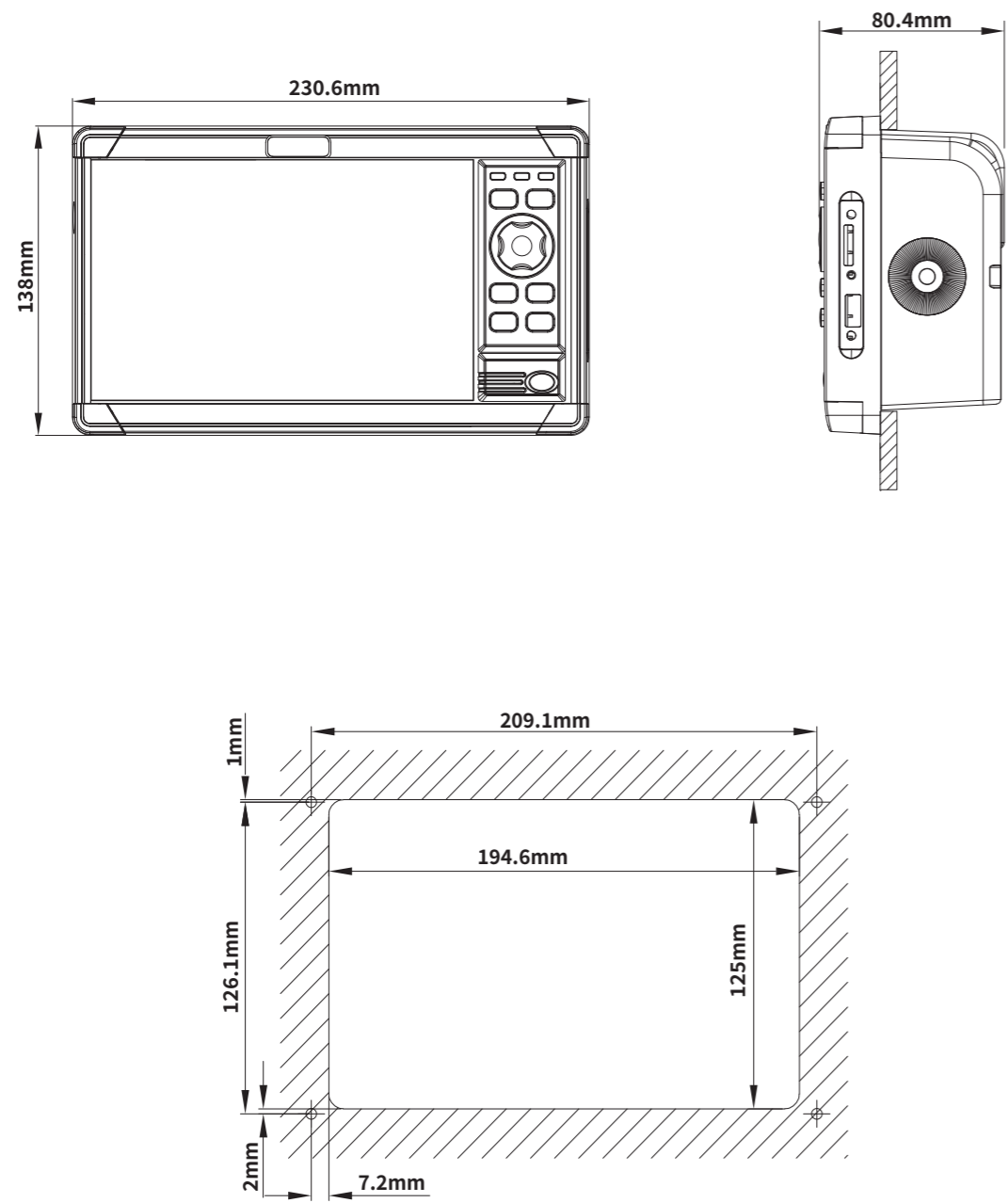

GNSS天线单元

定位信号在室内是无法接收到的, 定位天线必须安装在室外开阔无遮挡的地方。

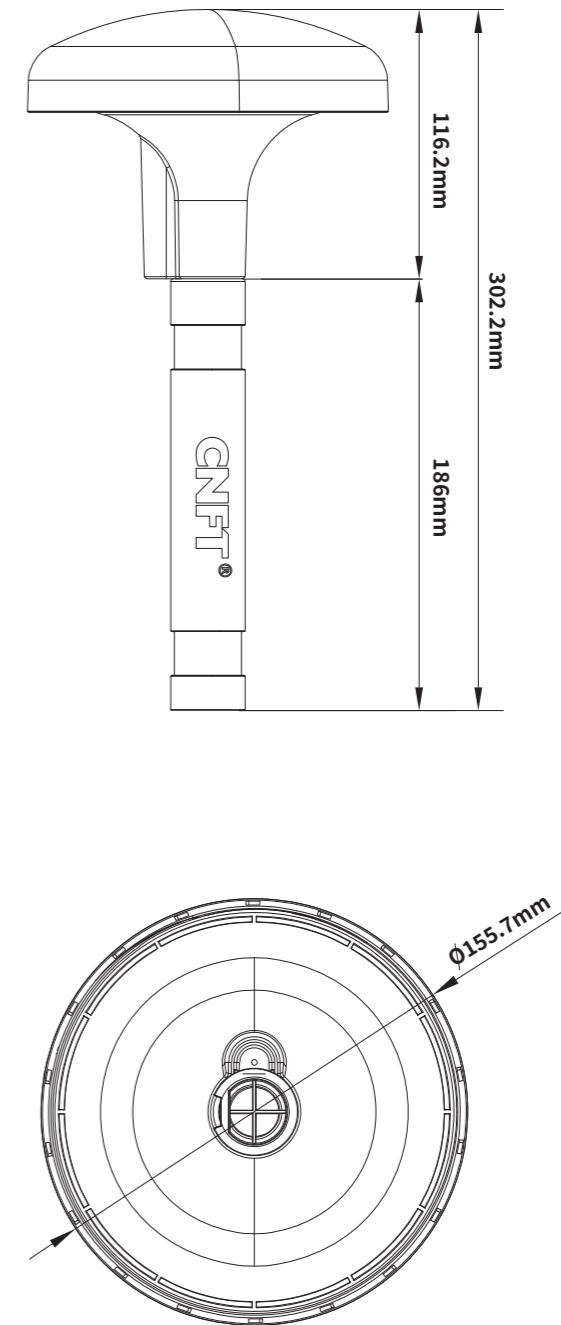

# 整机说明

## ■ 主机部分

### 面板说明

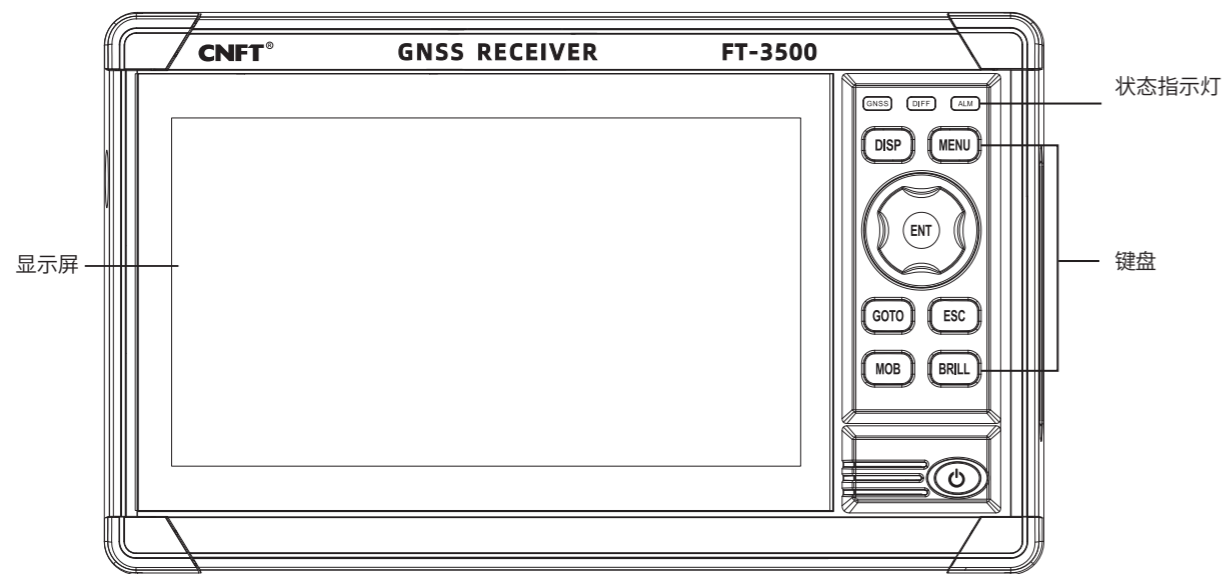

## ■ 显示单元前视图说明

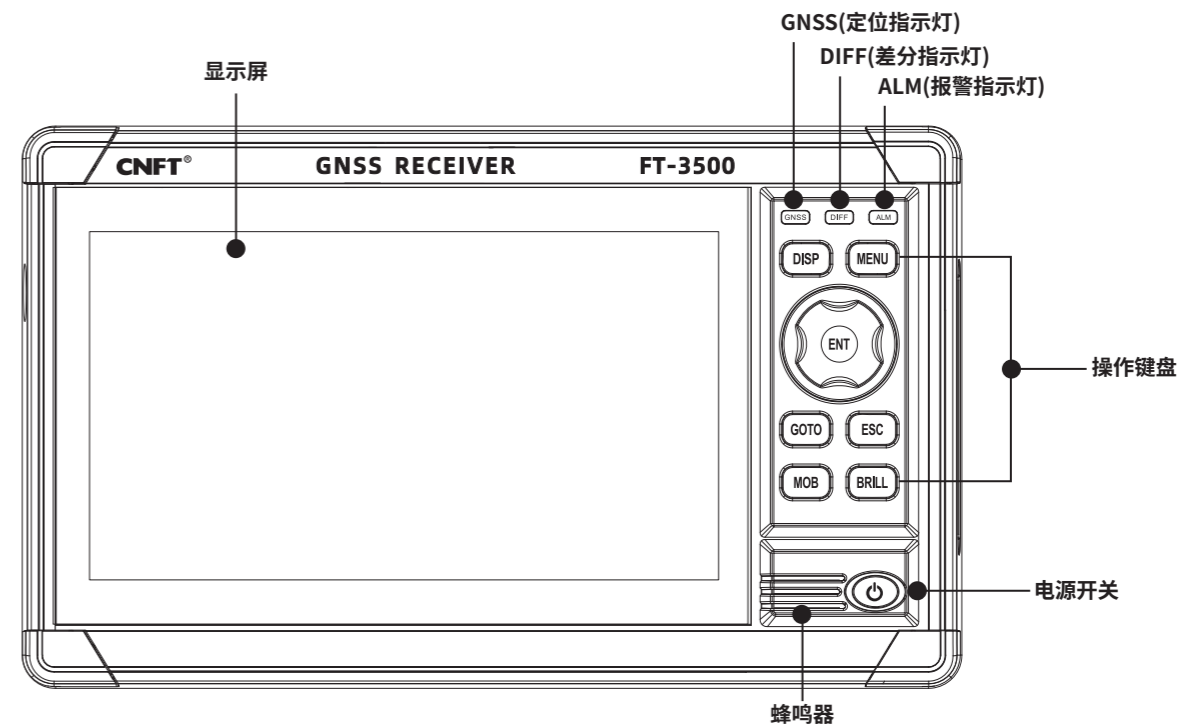

### 键盘：

[▲][▼][◀][▶]	方向键, 用于在菜单中导航和选择项目
图面	显示模式切换, 可在不同主界面间快速切换
菜单	菜单唤醒, 进入系统设置菜单
确认	确认键, 用于确认选择和执行操作
导航	快速跳转, 在航点列表中快速定位到指定航点
返回	用于取消操作或退出主菜单
MOB	快速记录当前船位
亮度	亮度调节/照明条件, 调节屏幕和按键亮度, 切换显示模式
⏻	用于开关机器电源

## ■ 显示单元后视图说明

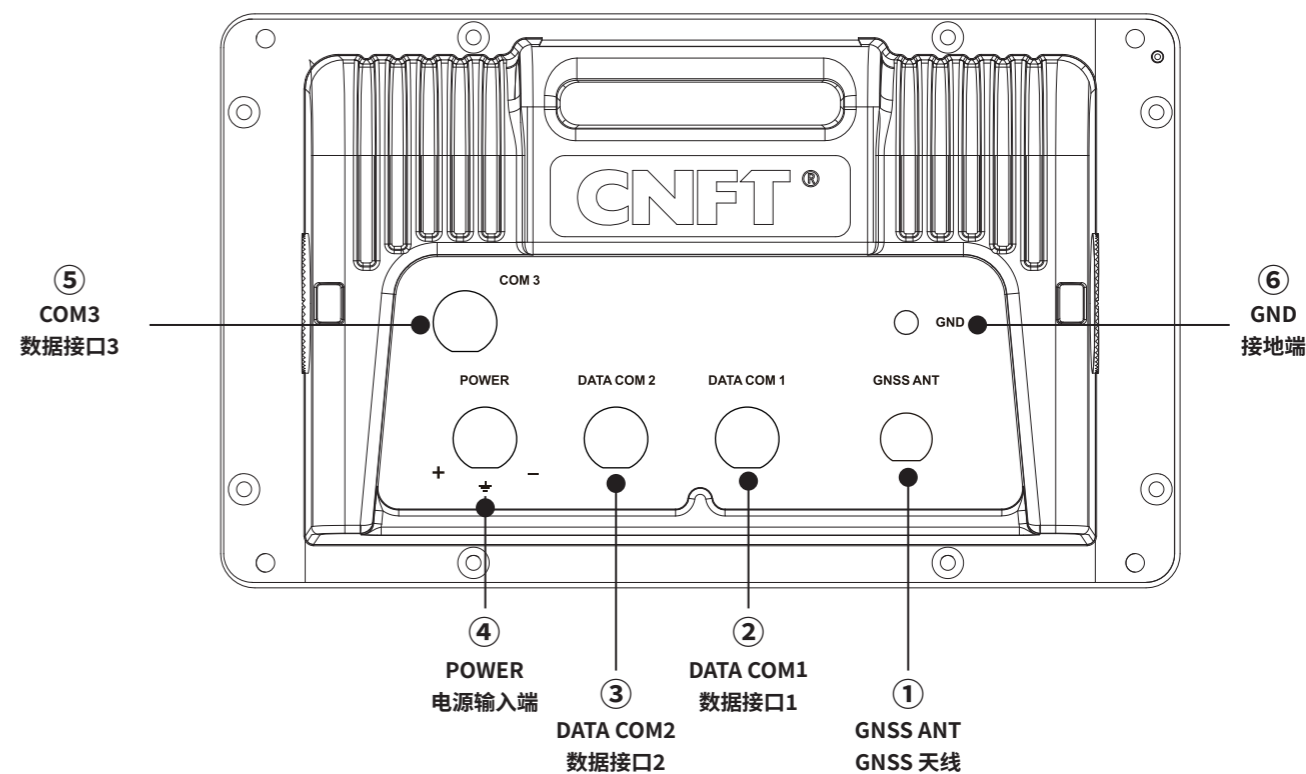

# 主要功能操作说明

## ◆开关机操作

按下“

长按“

## ◆亮度和显示模式调节

用户可根据自己的需求对设备显示进行调整，支持显示亮度、按键背光以及显示模式选择调节。

按[亮度]键，进入亮度调节页面；

按按[◀][▶]键或触屏调节屏幕亮度；

通过[▲][▼]键或触屏调节按键亮度；

使用触屏直接切换显示模式（自动、用户、白天、阴天、夜晚）；

按[确认]键，确认保存设置。

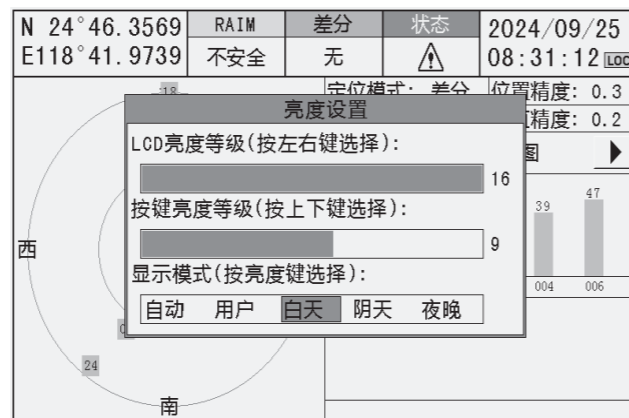

## ◆主界面切换操作

按[图面]键可快速切换主界面，包括定位界面、星历信息界面、航速航向界面、3D导航界面。

定位界面：显示当前位置、速度、航向等信息。

RAIM	PDOP	等级	差分	状态	2024/09/25
不安全	0.8	10m	无		08:24:58 <small>LOC</small>
WGS-84					
<b>N 24°46.3585</b>					
<b>E118°41.9748</b>					
FIX		SOG		COG (T)	
GN-3D		0.00 <sub>kt</sub>		0.0°	

按[图面]键切换至星历信息界面；

展示卫星连接状态及信号强度，也可查看定位模式、位置精度、水平精度及垂直精度等信息。

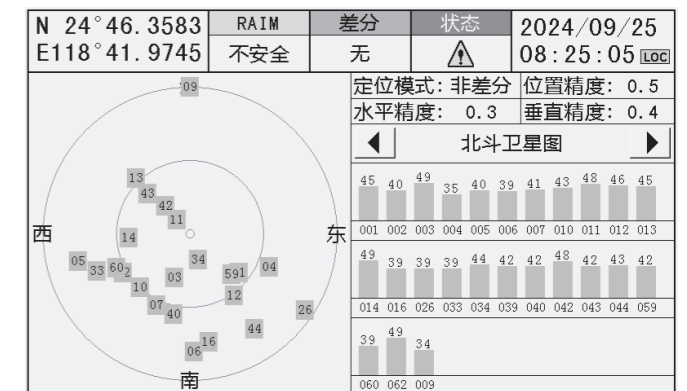
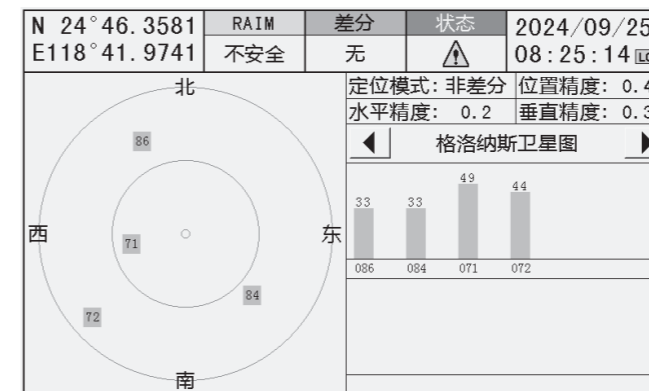
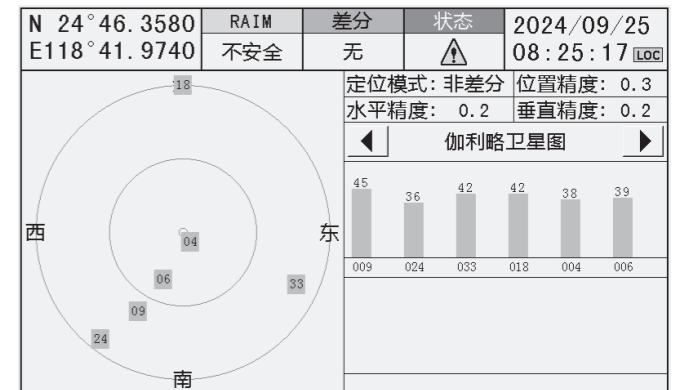
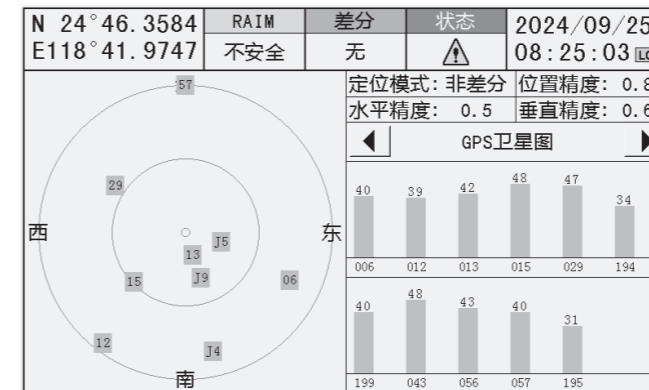

按[图面]换至航速航向界面，展示实时航速和航向变化。

按[图面]换至3D导航界面：提供三维视图，直观展现航行轨迹，可查看预到时间、方位、距离、目标等信息；通过触屏或方向键可以调整量程与视角。

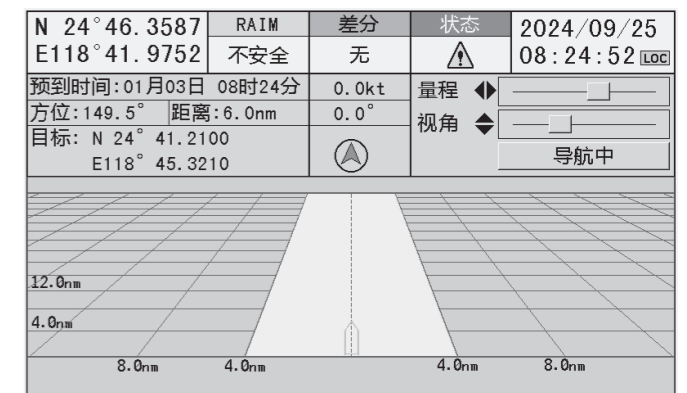
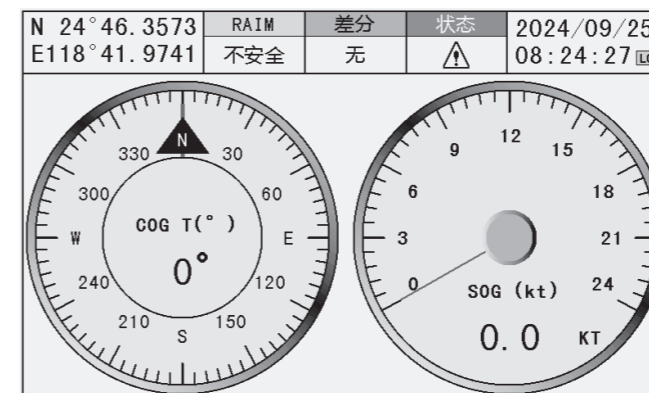

### ◆参数设置

对设备的内部参数进行设置，包括通信参数和定位参数。

按 [ 菜单 ] 键选择“参数设置”，跳出参数设置对话框，可通过[▲] [▼]键，选择“内部本机设置”中的“NMEA参数、波特率、定位频度、定位方式、差分修正、精度等级”的一项；再按 [ 确认 ] 键即可设置相关参数；如NMEA参数设置：设置DATACOM2口的GNSS输出内容，如RMC、GGA等。

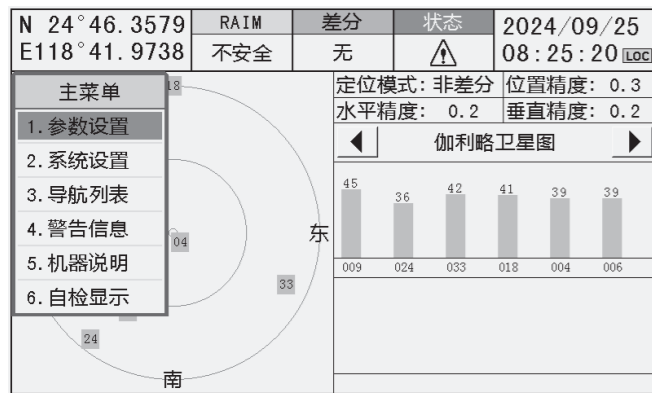

按 [▶] 键，选择“外部端口设置”中的“GNSS端口、数据端口、INS端口、AIS端口、DGNSS端口、艏向端口”的一项；再按 [ 确认 ] 键即可设置相关参数；如：GNSS端口参数设置：设置波特率设置及输出数据设置。



### ◆系统设置

设置系统语言、时区、距离单位等系统级参数。

按 [ 菜单 ] 键选择“系统设置”，跳出功能设置对话框，按[▲] [▼]键，选择需要修改的功能，再按 [◀] [▶] 键可修改设置。如：选择“语言”，按 [◀] [▶] 键可选择“简体/繁体”。

修改完成后，按 [ 确认 ] 键选择“保存”，如不保存选择“返回”。

按 [ 图面 ] 键或触屏点击“恢复出厂”，选择“确认”，即可恢复出厂设置。

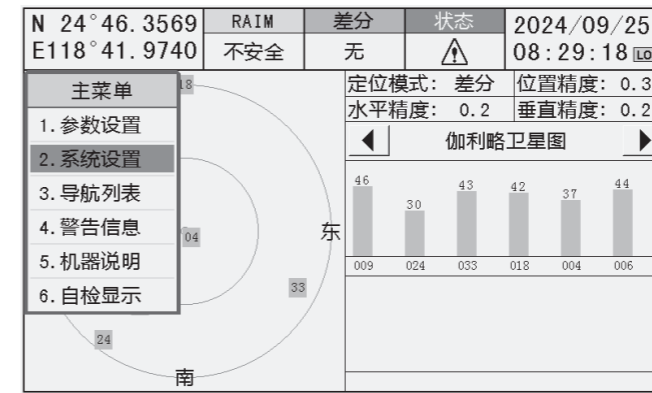

### ◆导航列表

#### ◇航点列表

管理和操作航点列表，包括编辑和导航功能。

按 [ 菜单 ] 键选择“导航列表”，按 [▶] 键选择航点列表，再按 [ 确认 ] 键进入“航点列表”界面，选择一条，再按 [ 菜单 ] 键，可对当前列表进行新建、编辑、删除（单条或全部）、排序、显示、导航、停止导航等操作。这一功能为用户提供了灵活的航点管理方案。

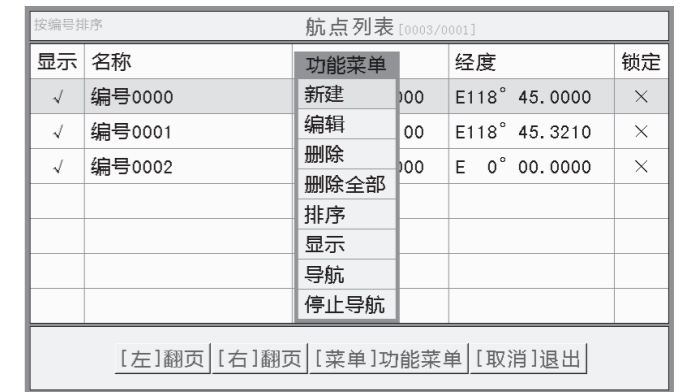
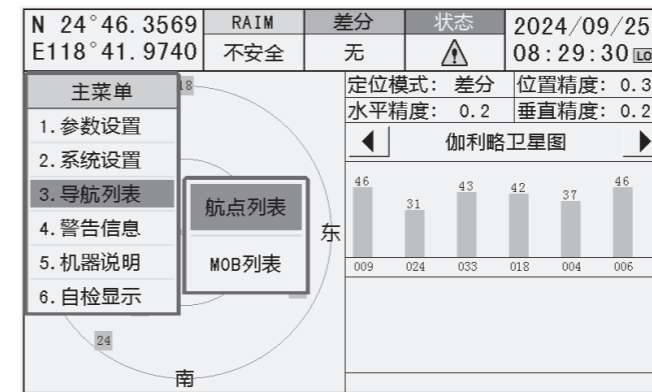

◇ MOB列表

管理和操作MOB列表。

按 [ 菜单 ] 键选择“导航列表”，按 [▶] 键选择MOB列表，再按 [ 确认 ] 键进入“MOB列表”界面，选择一条，再按 [ 菜单 ] 键，可对当前列表进行锁定、删除（单条或全部）、导航、停止导航等操作。这一功能确保了用户对动态目标的跟踪与控制能力。

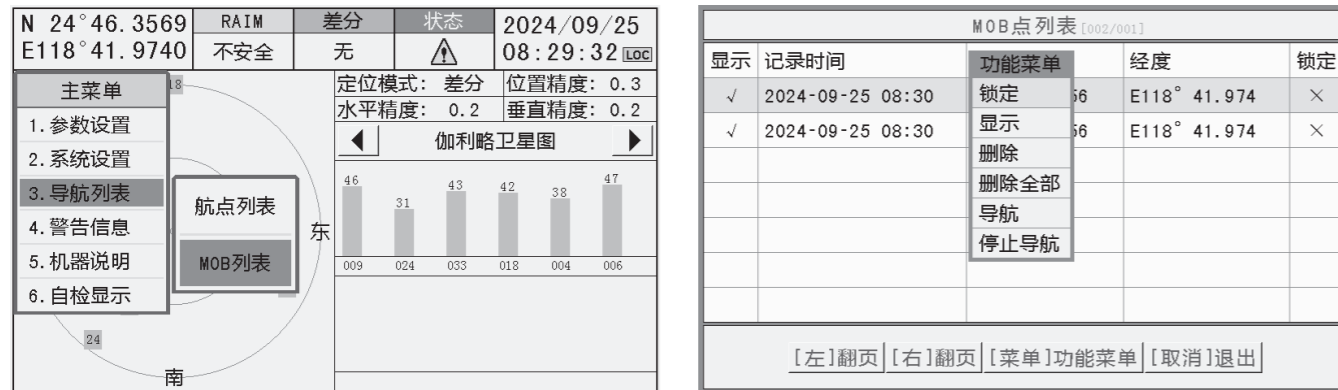

◆ 警告信息

◇ 警告列表

按 [ 菜单 ] 键选择“警告信息”，按 [▶] 键选择警告列表，再按 [ 确认 ] 键进入“警告列表”界面即可查看告警信息。选中一条列表，按 [ 图面 ] 键或触屏点击“查看”，即可查看“详细信息”，列表详尽列出了告警的状态、ID、发生时间、类型及原因，使用户能够迅速识别并响应紧急问题。按 [ 确认 ] 键，即可确认告警信息，从而快速介入处理。

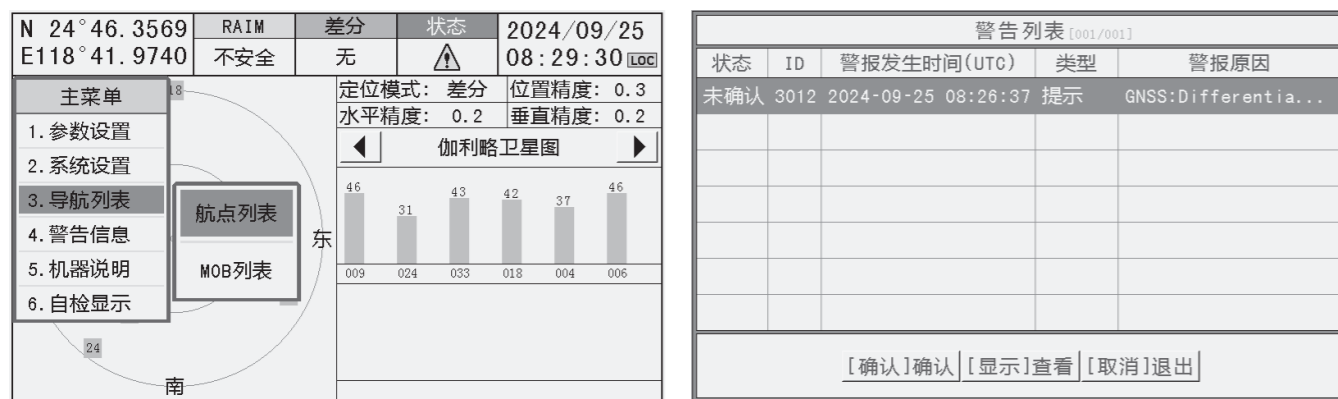

◇ 警告日志

按 [ 菜单 ] 键选择“警告信息”，按 [▶] 键选择警告日志，再按 [ 确认 ] 键进入“警告日志”界面。选中一条列表，按 [ 图面 ] 键或触屏点击“查看”，即可查看“详细信息”，此系统记录了设备运行期间发生的所有告警事件，无论这些告警是否已被解决。日志中包含了详尽的告警信息，如状态、ID、时间、类型和原因，是分析历史数据、评估系统性能及预防问题的重要资源。可通过左右键轻松翻阅历史警告信息，为问题追踪与系统优化提供有力支持。

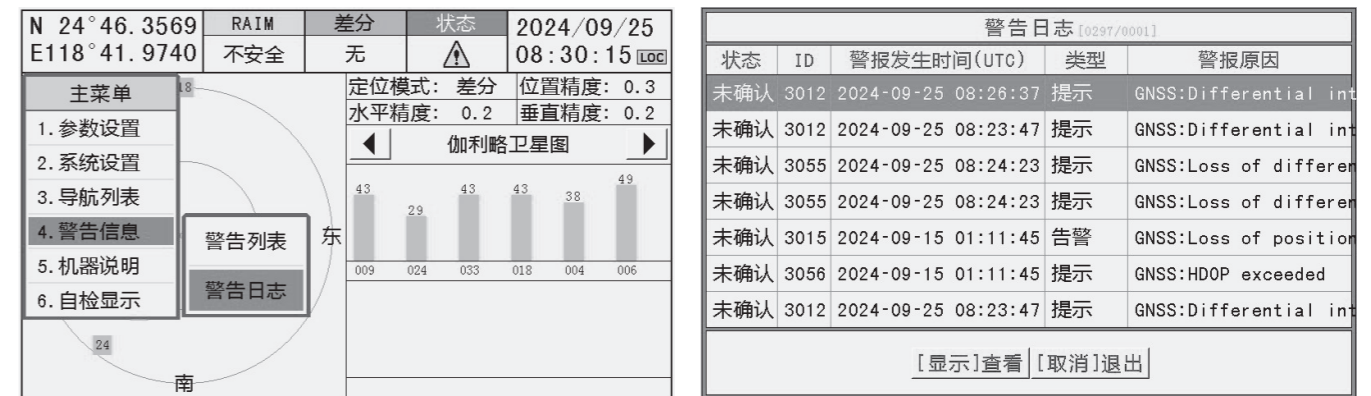

◆ 自检显示

按 [ 菜单 ] 键选择“自检测试”，该功能是设备内部检测流程的可视化呈现，通过自检显示，用户可以直观地确认系统各组件的工作状态是否正常，从而保障设备运行的稳定性和可靠性。此外，用户还可以利用自检界面来验证各端口的数据输入情况，以及输入的语句是否被设备正确识别，为设备的日常维护与故障排查提供了极大便利。



# 系统接口规格说明

## ■ 显示单元前视图说明

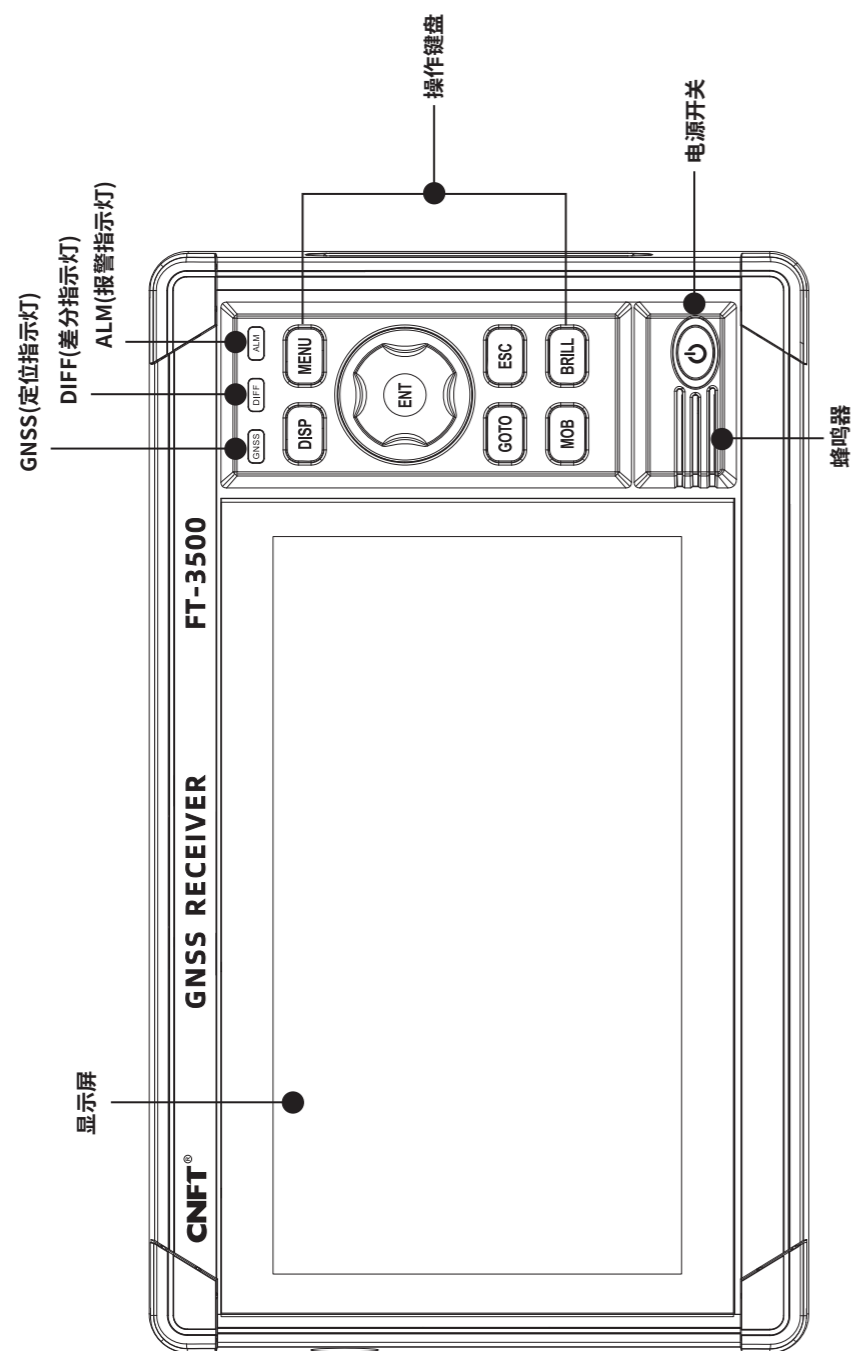

## ■ 显示单元后视图说明

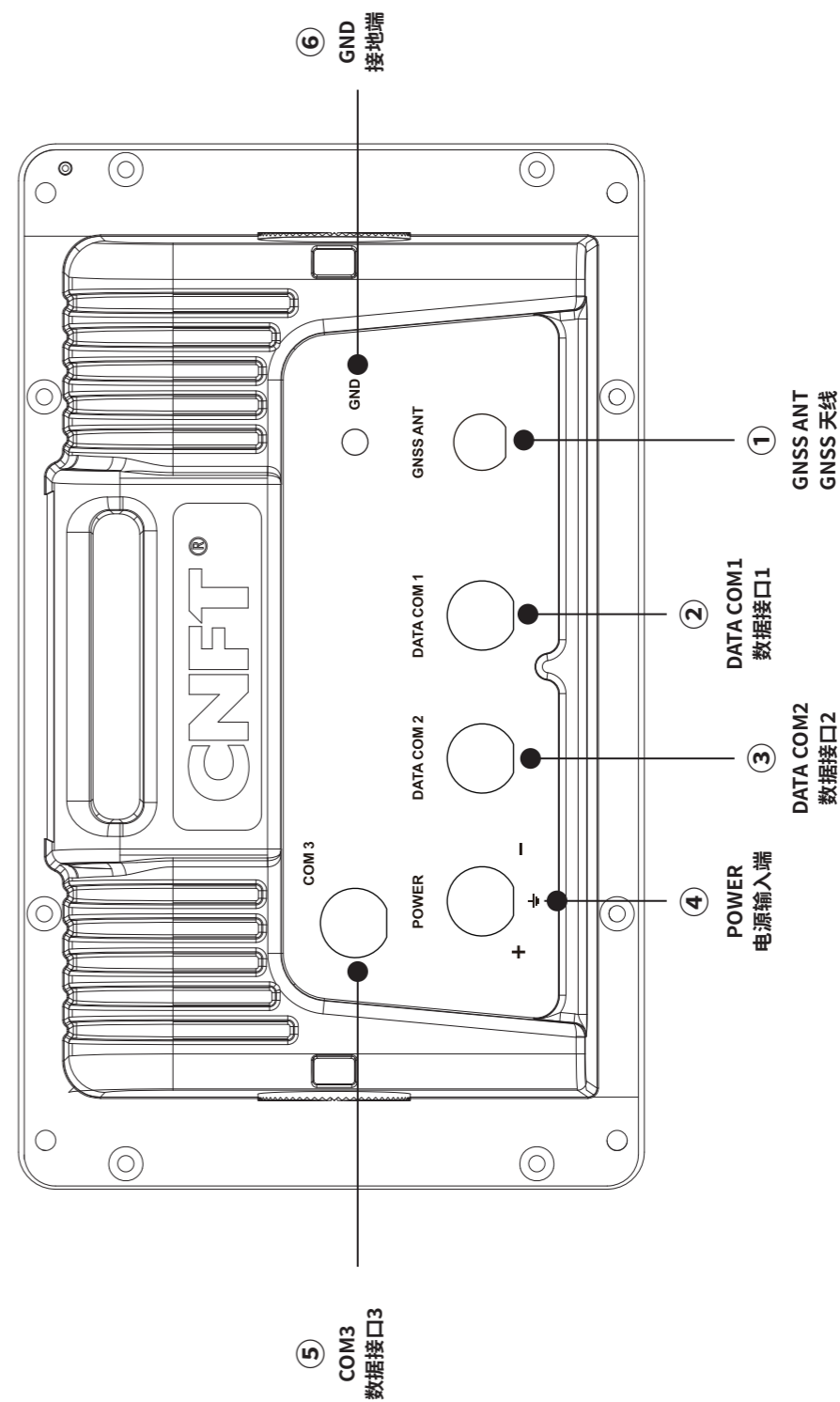

■ 显示单元后视接口规格

① GNSS ANT (外接GNSS天线接口单元)

② DATA COM1(数据接口1)

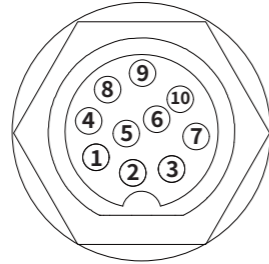

序号	定义	功能	
1	INS/BAM	422 TXD-	管理系统输出-
4		422 TXD+	管理系统输出+
2		422 RXD-	管理系统输入-
3		422 RXD+	管理系统输入+
5	GNSS OUT	422 TXD-	定位输出-
8		422 TXD+	定位输出+
6	DGNSS IN	422 RXD-	差分数据输入-
7		422 RXD+	差分数据输入+
9	ALARM	COMMON	报警接口公开端
10		N.O	报警接口常开端

③ DATA COM2(数据接口2)

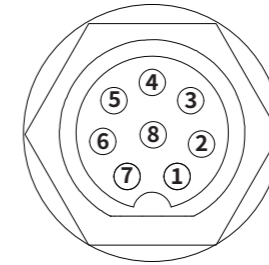

序号	定义	功能	
1	CAN	CAN_H	CAN通信接口H
2		CAN_L	CAN通信接口L
3	GNSS OUT	422 RXD+	定位输入+
4		422 RXD-	定位输入-
5	EXT.AIS	422 TXD+	AIS输出+
6		422 TXD-	AIS输出-
7	EXT.HDG	422 RXD+	航向输入+
8		422 RXD-	航向输入-

④ POWER(电源输入端13.8V (10.8V-15.6V))

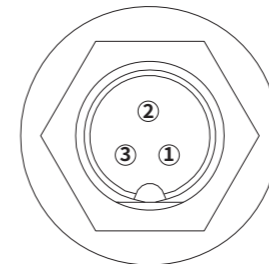

- 1: 电源输入负极端(-)
- 2: GND 接地端
- 3: 电源输入正极端(+)

⑤ COM3(数据接口3)

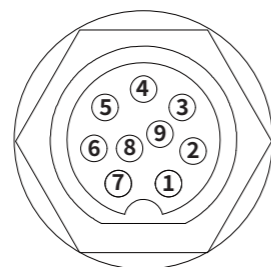

序号	定义	功能
1	VDD	DC 12V
2	GND	地
3	422 RXD+	422串口输入-
4	422 RXD-	422串口输入+
5	VDD	DC 12V
6	422 TXD+	422串口输出+
7	422 TXD-	422串口输出-
8	GND	地
9	GND	地

⑥ GND(总接地端)

## 更新与维护

### ■ 清洗外观

如果机器脏了或布满灰尘,可用软的干布擦拭。  
避免使用化学剂或酒精,因为这可能会损坏机器的表面。

### ■ 置换保险丝

如果保险丝断了或机器停止工作,那么必须查明原因,可能的话换新的保险丝。保险丝装在FUSE盒子内。

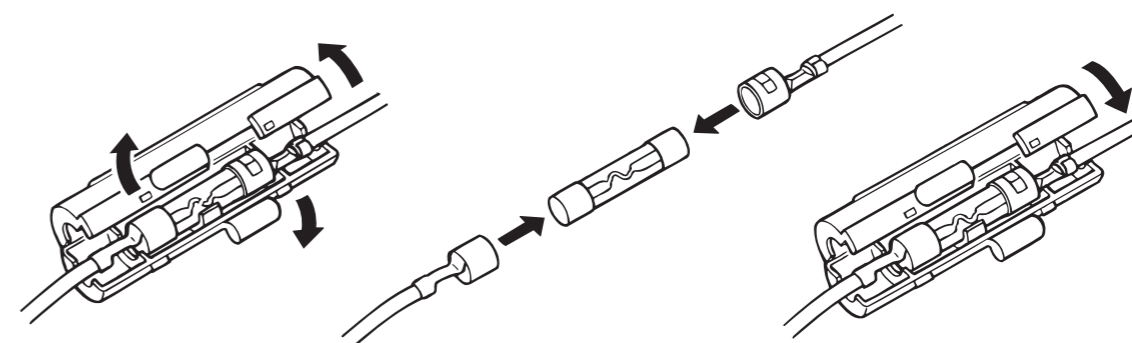

### ■ 疑难解答

电源	
电源打不开	检查电源接头是否接牢 检查电源正、负极是否接反 检查保险丝是否损坏 如不能恢复正常工作,请勿自行尝试检查设备内部
接收故障	
不能接收信息	检查距发射台是否超过400海里 检查天线电缆是否短路/开路 检查有没有强信号干扰,如雷达、电台或其他无线电 不能接收(除ABDL外的信息),应检查接收设置
显示故障	
字符看不清	检查调节对比度
有字符分断痕迹	联系售后服务