

CNFT[®]

OPERATOR'S MANUAL

FT-1101

甚高频(A级DSC)无线电装置

VHF Radio Device (Class A DSC)

福建飞通通讯科技股份有限公司

[FUJIAN FEITONG COMMUNICATION TECHNOLOGY CO., LTD.]

Tel/ +86-595-88481988
Web/ www.cnfeitong.com
Version/ V1.0.0

地址/ 福建省石狮市高新技术开发区电子信息园飞通科技大厦
Addr/ Feitong Technology Building, Electronic Information Park, Hi-Tech
Industrial Development Zone, Shishi City, Fujian Province, China.

福建飞通通讯科技股份有限公司

FUJIAN FEITONG COMMUNICATION TECHNOLOGY CO., LTD.

Safety Instruction

Danger!

- If any object falls into the device or water splashes onto it, immediately turn off the power at the distribution panel.
(Continued use may cause fire or electric shock)
- If the device emits smoke or catches fire, immediately turn off the power at the distribution panel.
(Continued use may cause fire or electric shock)
- If the device operates abnormally, immediately turn off the power at the distribution panel.
(Continued use may cause fire or electric shock; it is recommended to contact the agent/ distributor for consultation)

Warning!

- Be sure to turn off the power at the distribution panel before starting installation.
(Power-on during installation may cause fire or electric shock)
- Use only the specified power cable.
(Using other cables may cause fire or electric shock)
- Do not install the device in locations where it may be exposed to rain or splashing water.
(Water entering the device may cause fire or electric shock)
- Do not place containers filled with liquid on top of the device. (May cause fire or electric shock)
- Do not operate the device with wet hands. (May cause electric shock)
- Do not disassemble or modify the device. (May cause electric shock, fire, or personal injury)

Caution!

- Ensure the power supply voltage is compatible with the device's rated voltage. Incorrect power connection may cause fire or equipment damage. The rated voltage is indicated on the label on the back of the display unit.
- Handle the grounding copper strap with care; its edges may injure your hands.
- Maintain a minimum compass safe distance of 60MM.
- Grounding the device: Ungrounded equipment may emit or receive electromagnetic interference, or cause electric shock.



Warning!

- Do not perform operations inside the device unless fully familiar with electrical circuits.
- Hazardous voltages exist inside the device that may cause electric shock.

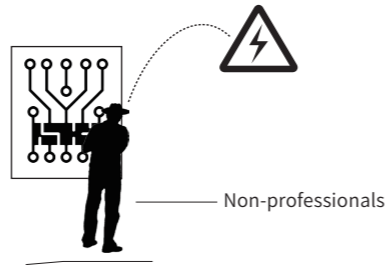

- Before starting installation, turn off the power at the main distribution panel. Post a sign near the switch indicating that the power should not be turned on during installation. Failure to turn off or accidental activation of power during installation may result in fire, electric shock, or serious injury.

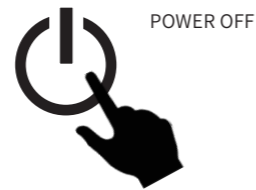

- Do not operate the distress button unless the vessel is in actual distress. (Activating the distress button will transmit a distress signal; if sent accidentally, immediately contact the coast radio station to report)

Contents

Safety Precautions	01	■ Medical Transport Call	30
Preface	03	■ Polling Call	30
Main Technical Specifications	03	Menu Operations	31-39
Installation Guide	04-09	■ Using the Menu	31
■ Electrical Installation.....	04	■ Editing User Channels	31
■ Fixed Installation	05	■ Address Book	32
■ Antenna Installation	09	■ System Settings	33
Panel Description	10-12	■ DSC Settings	34
■ Front Panel Layout.....	10	■ Memory Reset	39
■ Display Interface.....	12	■ Self-Test	39
Basic Operations	13-14	■ Service Information.....	39
■ Power On/Off	13	GNSS Device Connection	40
■ Channel Switching	13	Interface Specification	41-42
■ Radio Transmission & Reception.....	13	■ Front View Description of	
■ Dual Watch.....	13	Display Unit	41
■ Full Channel Scan.....	13	■ Rear View Description of	
■ Marking/		Display Unit	41
Memorizing Current Channel	13	■ Rear Interface Specification of	
■ Marking/		Display Unit	42
Memorizing Scanned Channels.....	14	Appendices	43-46
■ Priority Channel Scanning.....	14	■ USA Frequency Bands Table (USA)	43
■ Switching Display Modes.....	14	■ International Frequency	
■ Backlight Adjustment.....	14	Bands Table (INT)	44
Distress Alert Operations	15-19	■ Canada Frequency	
■ Distress Alert	15	Bands Table (CAN)	45
■ Distress Alert Relay Call	17	■ Weather Frequency	
Routine Call Operation	20-30	Bands Table (WX)	46
■ Individual Call	20	Maintenance	47
■ All Ships Call	22	操作手册中文版.....	48 (起)
■ Group Call	23		
■ PSTN Call	25		
■ Position Call	27		
■ Test Call	28		
■ DSC Call	29		
■ Neutral Craft Call	30		

Preface

Thank you for choosing our product, Model: FT-1101, Name: Very High Frequency (VHF) Radiotelephone (Class A DSC). The product includes the main unit and accessories provided as standard; please refer to the Packing List for details. Before installing and using this product, please carefully read the User Manual to prevent damage caused by improper operation or lack of professional handling, which may lead to equipment failure or personal safety risks. Our company does not assume any liability for consequences arising from improper use. **※ Note: If product upgrades or updates result in discrepancies between the User Manual and actual device operation, the device specifications shall prevail.**

Main Technical Specifications

Item	Technical Specifications
Power Supply	DC 12V (Operating range: 10.8V to 15.6V)
Channel Capacity	57 international maritime channels with an extension of 100 private channels
Frequency Bandwidth	25KHz
Frequency Generation Method	Frequency Synthesis
Radio Receiver	Dual Conversion Superheterodyne Design, Multi-channel Reception
	Frequency Range: 156.025MHz~163.275MHz
	Intermediate Frequencies: 21.7MHz; 450KHz
	Maximum Usable Sensitivity: ≤6dBμV (e.m.f.) at 20dB/SINAD
	Adjacent Channel Selectivity: ≥70dB ,Spurious Response Rejection: ≥70dB
	Intermodulation Distortion Resistance: ≥65dB
	Spurious Emission: ≤2nW
	Current Consumption: 0.9A (Max Audio) 0.4A (Standby)
70-Channel DSC Receiver	DSC Receiver (CH70 - 156.525MHz) Sensitivity: ≤6dBμV (e.m.f.) (with BER <1%)
	Bandwidth: 16KHz ,First Intermediate Frequency: 17.9MHz ,Second Intermediate Frequency: 455KHz
	Adjacent Channel Selectivity: ≥70dB ,Spurious Response Rejection: ≥70dB
	Intermodulation Distortion Resistance: ≥65dB, Reception Mode: G2B
Radio Transmitter	Spurious Emission: ≤2nW, 9KHz to 2GHz
	Modulation Type: G3E (Voice), G2B (DSC),
	Transmit Frequency Range: 156.025MHz~157.425MHz
	Output Power: 25W, 1W (50 Ohms) , Audio Harmonic Distortion: ≤10%
	Audio Frequency Response: +1/-3dB of +6dB/octave, Pre-emphasis (300 - 3000Hz)
Residual Modulation: ≤-40dB, Peak Frequency Deviation: 5KHz	
Spurious Emission: ≤0.25μW , Current Consumption: ≤5A (Max)	

Installation Guide

Electrical Installation

Before operating the device, ensure proper connection of the power supply, antenna, and any external equipment. The device requires a ****12V DC power supply**** with an output current of at least 5A.

System Connection Diagram

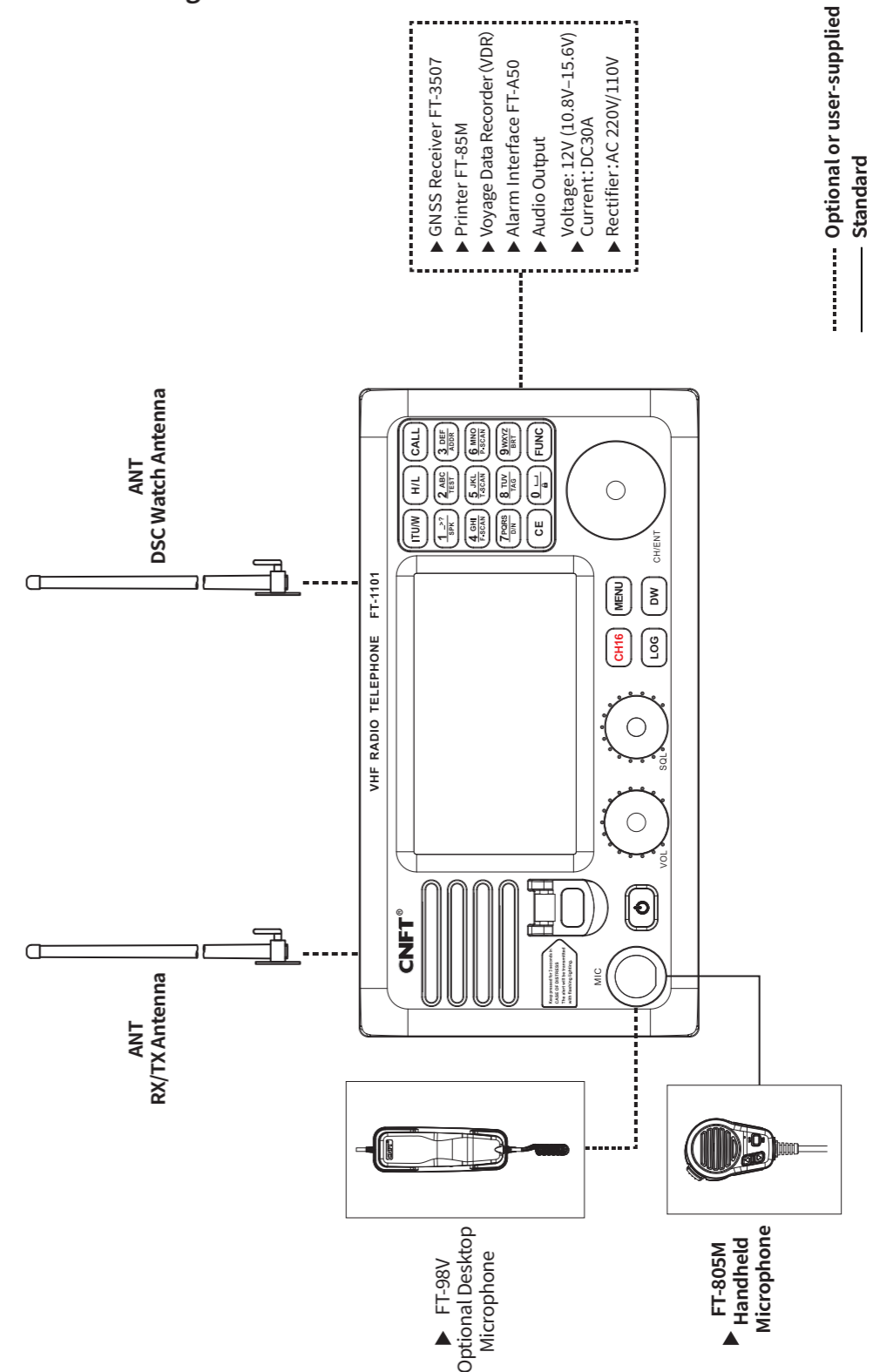

■ Fixed Installation

- ※ The product should be installed in a well-ventilated area, away from the engine.
- ※ Do not install the product in direct sunlight.
- ※ Keep the product at least 1 meter away from the compass.

The product is equipped with an adjustable mounting bracket, secured with five screws. Before installation, ensure a clearance of 100mm vertically and 70mm horizontally behind the bracket for proper adjustment. The tilt angle of the product can be adjusted using the clamp.

Desktop Mounting

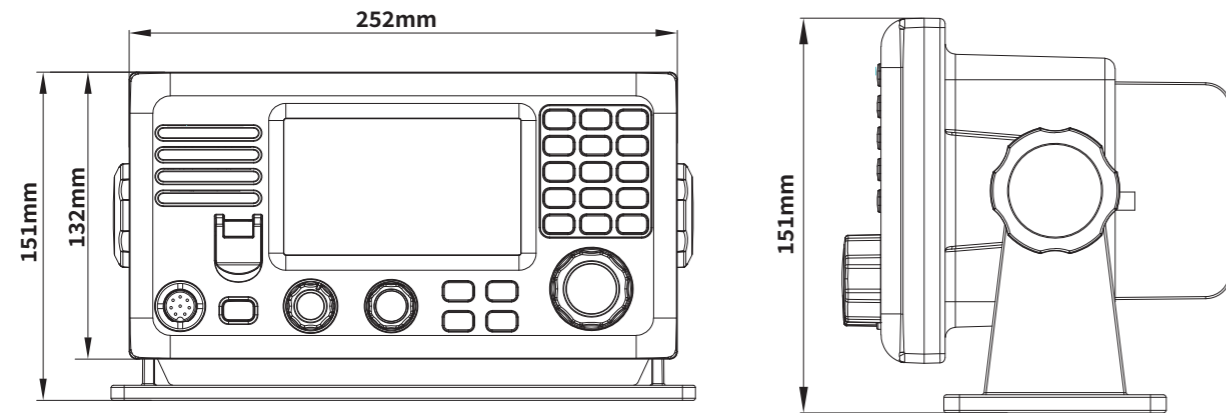

Overhead Mounting

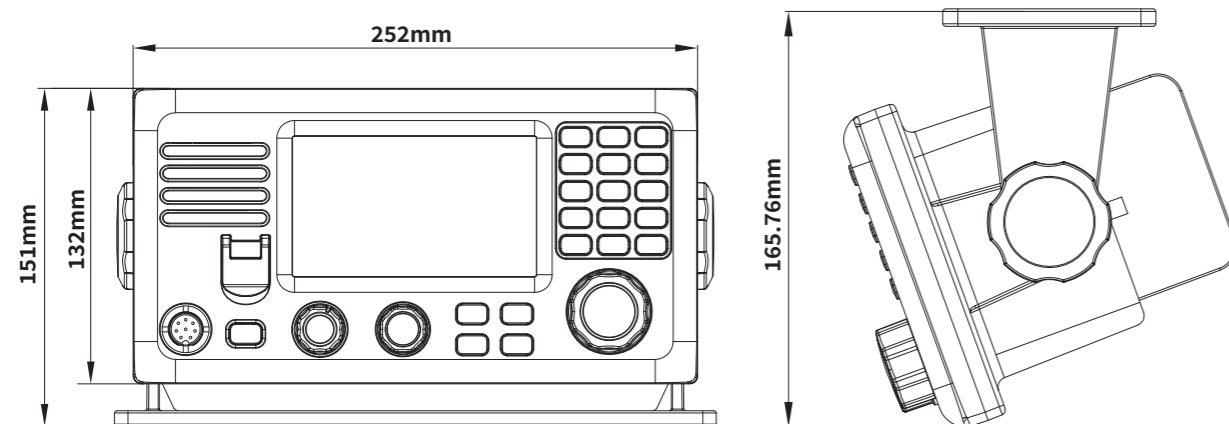

Embedded Mounting

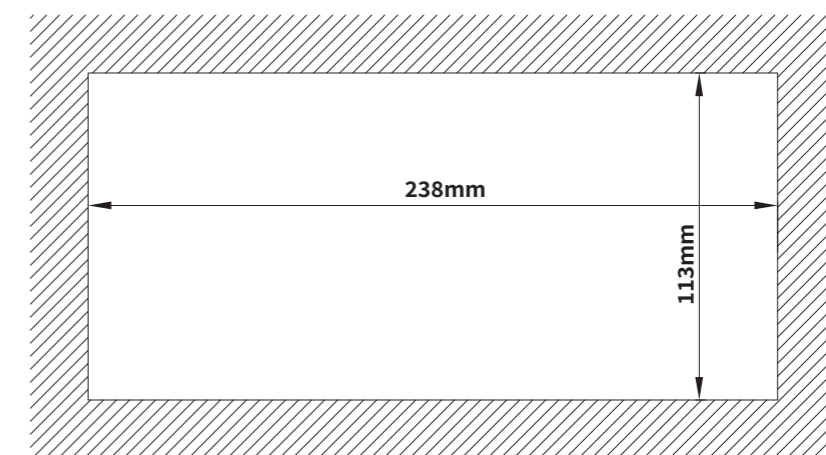
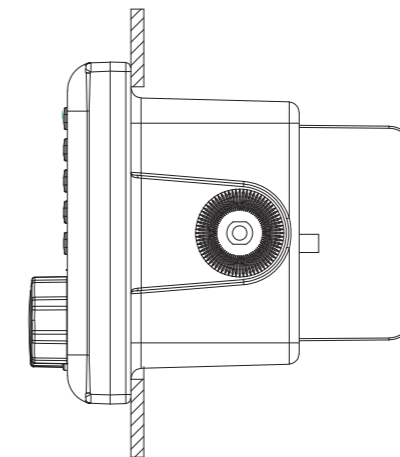
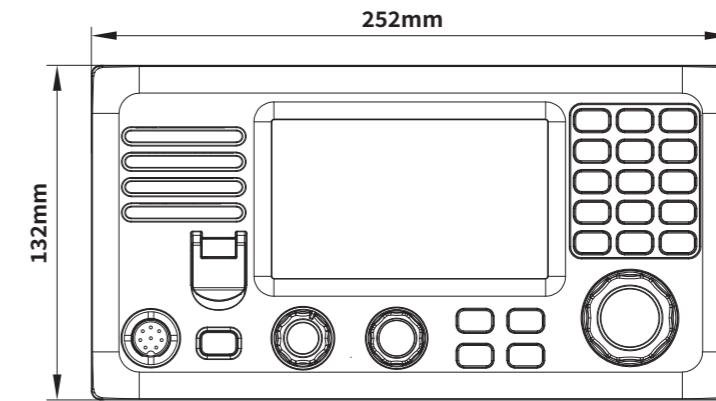

Front View

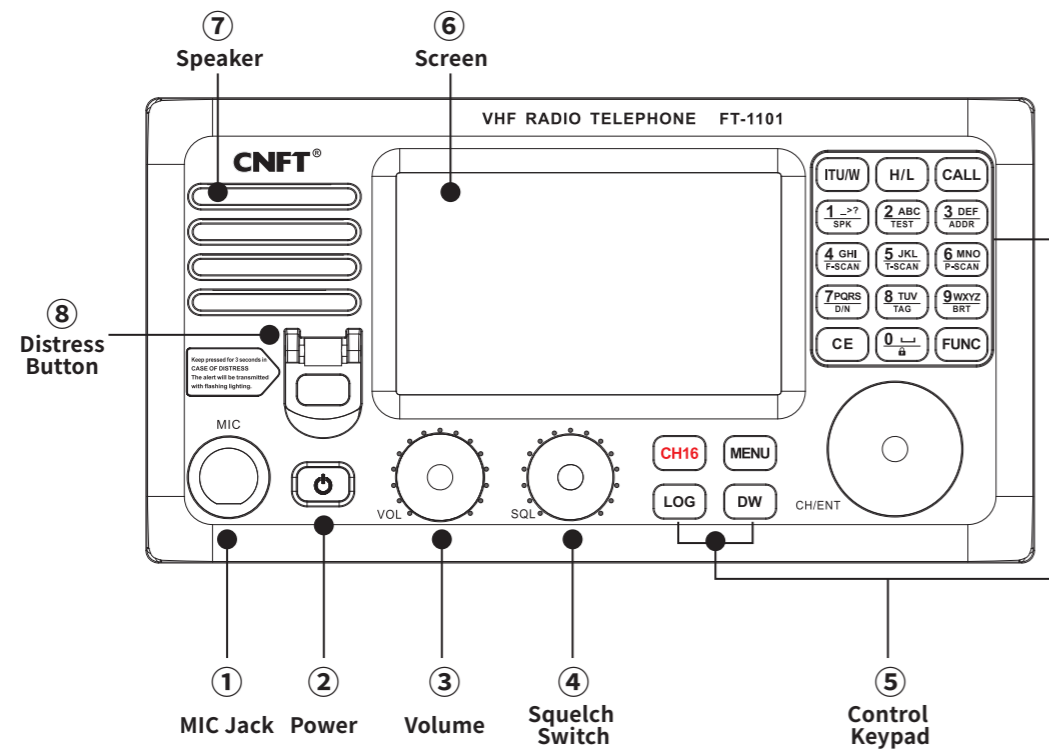

Rear View

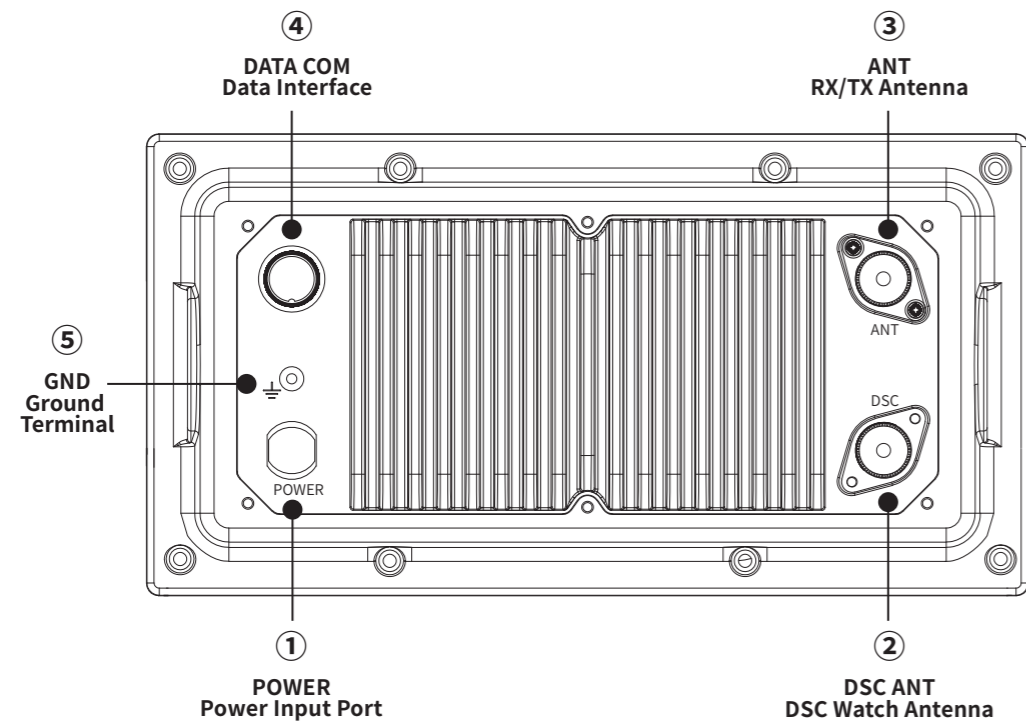

Assembly Diagram

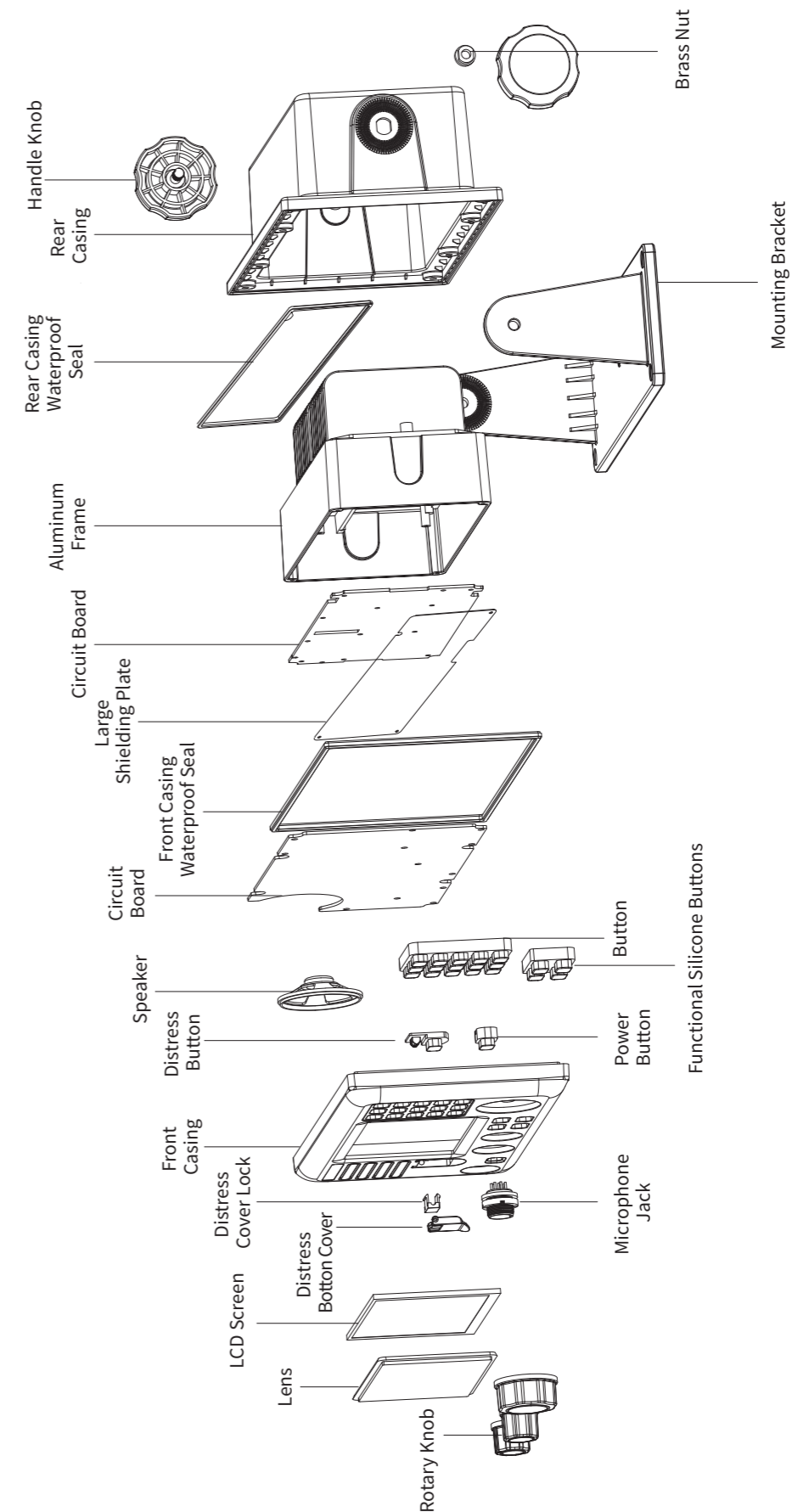

Antenna Installation

Antenna Installation Diagram

Proper antenna installation is crucial for minimizing interference and achieving optimal communication range. Please note the following points during installation:

- ① The antenna should be mounted in a vertical position and kept as far as possible from conductive objects on a horizontal plane. The minimum distance should not be less than 0.5 meters. The antenna should not be placed near large vertical objects and must maintain 360° unobstructed clearance.
- ② The antenna should be kept away from high-power transmitters, such as radar, radio stations, or other wireless antennas. Ideally, maintain a minimum distance of 3 meters.
- ③ Two antennas should not be installed on the same side. If they must be on the same side, ensure a minimum spacing of 10 meters. If conditions do not allow, install the antennas vertically, with a height difference of at least 2.5 meters.
- ④ Outdoor cable interfaces must be waterproofed.
- ⑤ Antenna cable length should be kept as short as possible and should be kept away from power cables. If crossing power cables, maintain a 90° perpendicular angle.
- ⑥ If installing on a light pole, use insulating materials for isolation and ensure the height is at least 1.5 meters above ground.

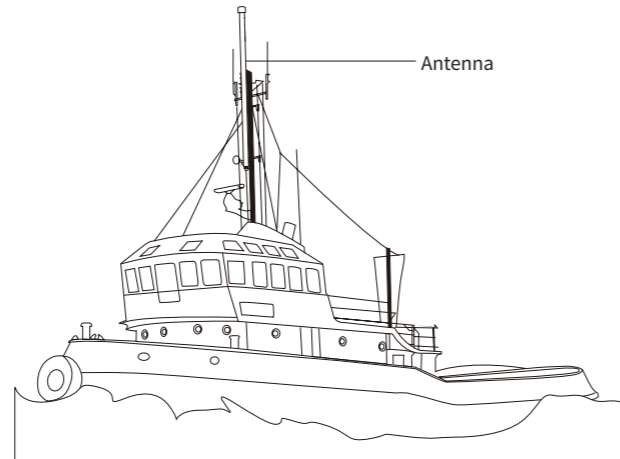

Whip Antenna Installation Diagram

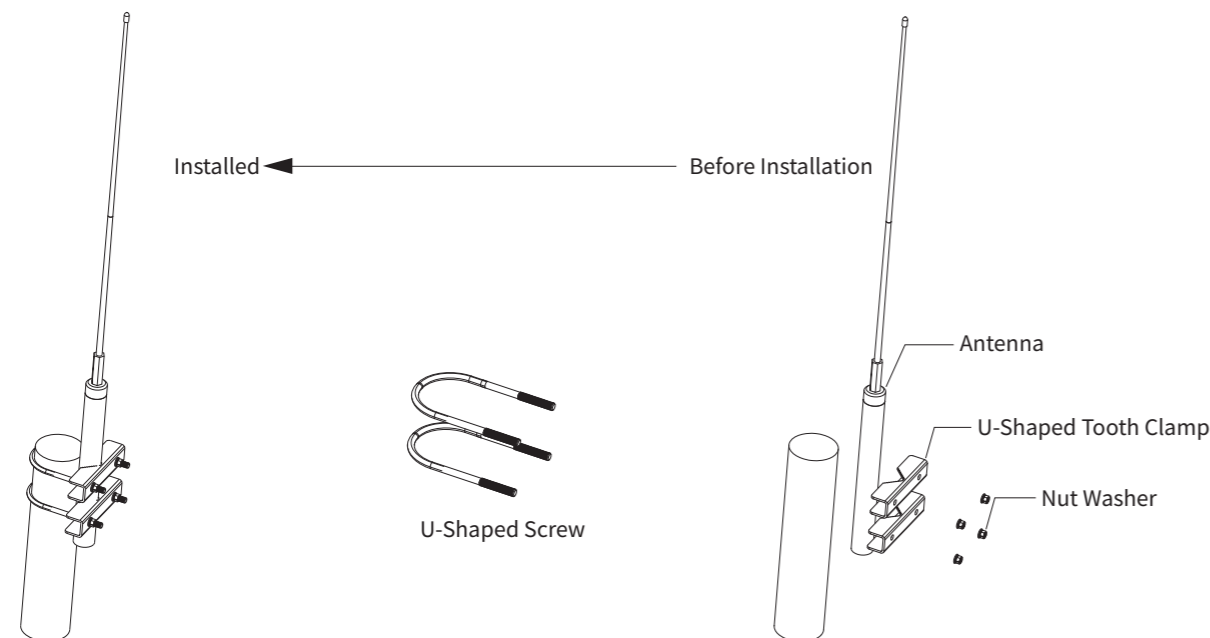

Panel Description

The FT-1101 VHF Radiotelephone (Class A DSC) is a multi-functional radio equipped with DSC capabilities, supporting features such as band switching, scanning, watchkeeping, and private channels. The device is built with an aluminum alloy frame, high-quality components, waterproof protection, and a reliable combination of hardware and software technologies. A large LCD screen and intuitive button interface enhance usability.

Front Panel Layout

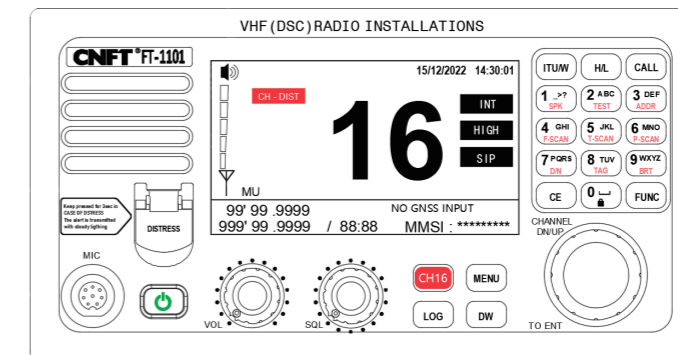

Keyboard Functionality

FUNC	When activated, the display shows the "FUNC" indicator. Pressing a numeric key enables its secondary function
1 .-? SPK	Default Function <Key 1>, Secondary Function <Speaker>: Toggle internal speaker output ON/OFF
2 ABC TEST	Default Function <Key 2>, Secondary Function <Test>: Open the DSC test call editor, allowing sending/saving of the call
3 DEF ADDR	Default Function <Key 3>, Secondary Function <Address Book>: Open the contact list
4 GHI F-SCAN	Default Function <Key 4>, Secondary Function <Full Scan>: Enable full channel scan mode
5 JKL T-SCAN	Default Function <Key 5>, Secondary Function <Tag Scan>: Enable tagged/memory channel scan mode
6 MNO P-SCAN	Default Function <Key 6>, Secondary Function <Priority Scan>: Enable priority channel scan mode
7 PQR D/N	Default Function <Key 7>, Secondary Function <Display>: Switch the main screen theme - DAY mode: White background, black text - NIGHT mode: Black background, white text
8 TUV TAG	Default Function <Key 8>, Secondary Function <Tag>: Mark/save the current channel
9 WXYZ BRT	Default Function <Key 9>, Secondary Function <Backlight>: Open the brightness adjustment dialog
0 LOCK	Default Function <Key 0>, Secondary Function <LOCK>: Lock button/knob operations - When activated, the display shows the "LOCK" icon, disabling all button and knob operations - Press again to unlock and remove the "LOCK" icon
DISTRESS	Lift the red protective cover, then press and hold the button for 5 seconds to send a distress alert.

MIC	Microphone Jack
	Power Switch : After correctly connecting the power supply, press and hold for 3 seconds to turn the device ON/OFF.
VOL	Volume Control : Adjusts the audio output level. Rotate clockwise to increase the volume, counterclockwise to decrease.
SQL	Squelch Control : Adjusts the receiver's squelch level. Rotate clockwise to deepen squelch filtering, counterclockwise to reduce squelch intensity.
LOG	Open the numeric call log selection.
DW	Enable dual watch mode.
CH16	Quickly switch to CH16 channel.
MENU	Open the system main menu.
CHANNEL	Channel knob: - In the main interface, selects the working channel. - In menu mode, selects the cursor position. - Pressing the knob functions as the [ENT] key.
ITU/W	Select frequency band: - Pressing the knob cycles through four frequency bands: International (INT), U.S. (USA), Canadian (CAN), and Weather (WX). - If the International, U.S., or Canadian band is selected, the radio automatically switches to CH16. - If the Weather band is selected, the radio automatically switches to CH01.
H/L	Power switching: - High power (HIGH) → 25W - Low power (LOW) → 1W
CALL	Open the call list menu to edit, send, or save a call.
ESC	Cancel the current operation and return to the previous menu.
LCD	5-inch TFT display.

◇ Display Operation Instructions

NO.	Description
1	Internal speaker status, default is ON
2	Received signal strength / transmission output power indicator
3	Own-Ship GNSS Information
4	Own-Ship 9-Digit MMSI Number
5	Own-Ship GNSS Information Input
6	Current channel attribute Same frequency → RX_freq = TX_freq Different frequency → RX_freq ≠ TX_freq
7	Current channel output power status High power → 25W Low power → 1W Transmission prohibited → This channel prohibits transmission
8	Current Band: International → INT U.S. → USA Canada → CAN Weather → WX
9	Local Date & Time

◇ Display Interface

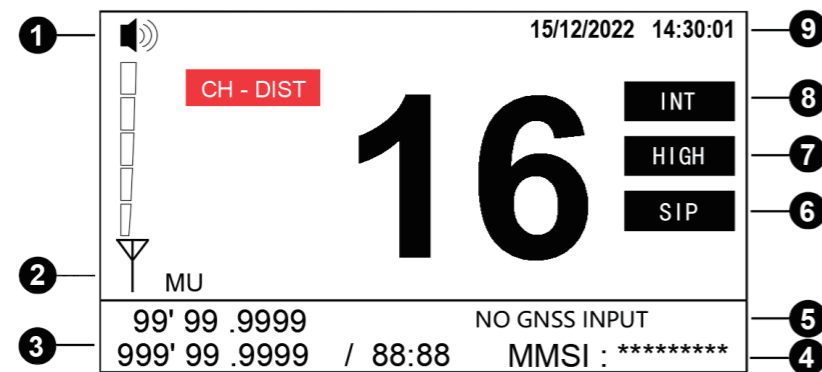

Basic Operations

◆ Power On/Off

Press and hold for 3 seconds to power ON/OFF after correct power connection.

◆ Channel Switching

Rotate the CH/ENT knob to switch channels.

Alternatively, enter the target channel using the numeric keys, then press [ENT] to confirm.

◆ Radio Transmission & Reception

Receiving: The device is standby upon power-up, displaying "MU". If a signal is detected, the screen turns green, displaying "RX" & "BUSY". Signal strength varies from 0 (weak) to 5 (strong).

Transmitting: Press the PTT button to initiate transmission; the screen turns red, displaying "TX" & "BUSY". Transmission power varies from 1 (low) to 5 (high).

◆ Dual Watch

Alternates between the current channel and CH16.

Press the DW button to start scanning (SCAN displayed).

If a signal is detected on watch channels, scanning continues without pausing.

If a signal is detected on CH16, the device remains on CH16 until the signal disappears.

After 30 seconds of no signal, scanning resumes.

Operators can press PTT to respond, exiting Dual Watch mode.

Press [CE] to stop scanning.

◆ Full Channel Scan

Scans all channels within the current band, including private channels (if set).

Press FUNC, then [4/F-Scan] to start scanning (SCAN displayed). Press [CE] to stop scanning.

Scanning sequence:

1. Adjust using the CH/ENT knob (rotate left/right).
2. Use Mic buttons ▲ / ▼ for up/down scanning.

When a signal is detected, the device pauses on the channel to monitor.

If the signal disappears, after 30 seconds, scanning resumes.

Operators can press PTT to respond, exiting scan mode.

◆ Marking/Memorizing Current Channel

Press [FUNC], then [8/TAG] or [ENT] to mark/save the current channel.

◆ Marking/Memorizing Scanned Channels

Scans marked channels within the current frequency band. Press [FUNC], then [5/T-SCAN] to start scanning.

The display will show "SCAN." Private channels (if configured) will also be included.

Scanning order can be adjusted by rotating [CH/ENT] or using [▲]/[▼] on the microphone.

When a signal is detected, the device pauses to monitor. If the signal disappears for 30 seconds, scanning resumes.

During scanning, press [PTT] to communicate, exiting scan mode.

Press [CE] to stop scanning.

◆ Priority Channel Scanning

Alternates scanning between marked channels and [CH16]. Press [ENT], then [6/P-SCAN] to start scanning.

The display will show "SCAN."

Scanning order can be adjusted using [CH/ENT] or [▲]/[▼] on the microphone.

If a signal is detected on a marked channel, scanning continues without stopping.

If a signal is detected on [CH16], the device pauses to monitor until the signal disappears. If inactive for 30 seconds, scanning resumes.

During monitoring, press [PTT] to communicate, exiting scan mode.

Press [CE] to stop priority scanning.

◆ Switching Display Modes

On the main screen, press [FUNC], then [7/D-N] to toggle between [Day Mode] and [Night Mode].

Press [CE] to exit.

◆ Backlight Adjustment

The screen has 10 brightness levels. Press [FUNC], then [9/BRT] to open the brightness menu.

Adjust brightness by rotating [CH/ENT] or using [▲]/[▼] on the microphone.

Press [CE] to exit the menu.

Distress Alert Operations

※ DSC operation requires a valid MMSI number. If there is no valid MMSI number, pressing [DISTRESS] and [CALL] will trigger a warning message. The following operations assume the device has a valid MMSI number and is properly connected to the GNSS system.

◆ Distress Alert

◇ Sending a Distress Alert

a: Press [DISTRESS] to open the distress alert call interface, as shown in Figure 4.1.1.

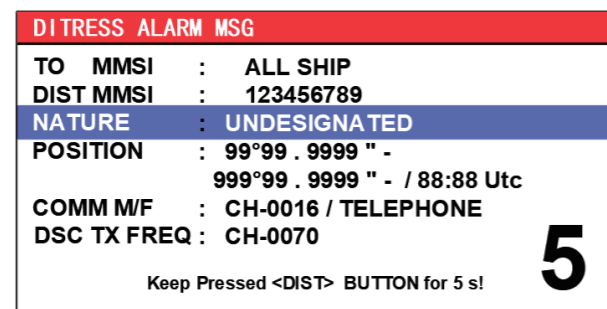

Figure 4.1.1

b: Press [ENT] to open the distress type list, then use the [CH/ENT] knob to select the distress type.

Available types: Fire, Flooding, Collision, Grounding, Listing, Sinking, Adrift, Undesignated, Abandon, Piracy, Man Overboard, Error Type (12 types). The default selection is Undesignated.

c: The device allows manual input of GNSS information. Rotate the [CH/ENT] knob to move the cursor to <Position>, then press [Number] to open the GNSS input dialog. Enter the correct GNSS coordinates and press [ENT] to confirm.

d: Press and hold [DISTRESS] for 5 seconds to send the distress alert call.

After sending the distress alert call, the device enters waiting for acknowledgment mode, automatically switching to CH16 for communication. During this mode, the distress alarm sound will repeat randomly within a 20–50 second range.

If no acknowledgment call is received within 3.5–4.5 minutes, the device automatically retransmits the distress alert call.

- Selecting <Stop> prevents automatic retransmission.

- Selecting <Resend> immediately retransmits the distress alert call.

If a distress alert call is accidentally sent, follow the cancellation procedure immediately.

a) In waiting for acknowledgment mode, select <Cancel> or press [CE] to send a distress alert cancellation message.

b) Use radio communication on CH16 to report vessel information.

Example:

“All ships... All ships... All ships... This is (vessel name and call sign), MMSI XXXXXXXX. My position is XX°XX' N, XXX°XX' E. On XXXX-XX-XX at XX:XX, I cancel my undesignated distress alert.”

c) Proceed with other operations.

◇ Receiving a Distress Alert Acknowledgment

When the device receives an acknowledgment, an alert sound will be triggered, and the display will show the acknowledgment details, as illustrated in Figure 4.1.2. The device will automatically switch to CH16 for communication.

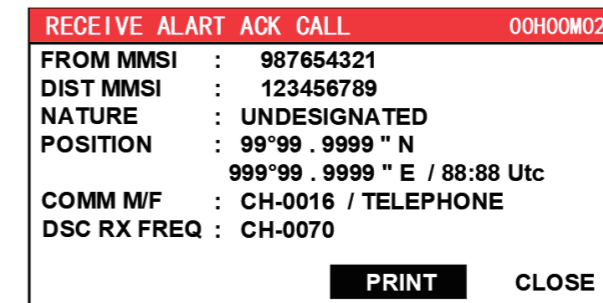

Figure 4.1.2

◇ Receiving a Distress Alert

When the device receives a distress alert, an alert sound will be triggered, and the display will show the distress call details, as illustrated in Figure 4.1.3. The device will automatically switch to CH16 for communication.

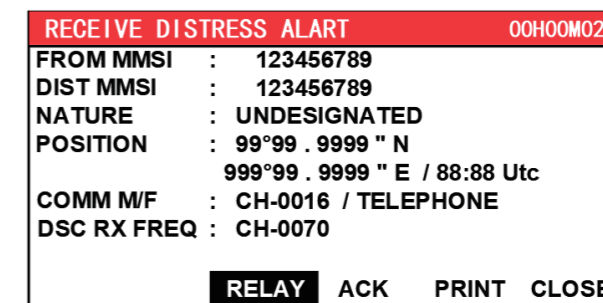

Figure 4.1.3

If relaying the distress alert, select <Relay>, press [ENT] to open the relay type menu, choose to relay to an individual or all ships, then press [ENT] again to send the call.

To send a distress alert acknowledgment call, select <ACK>, then press [ENT] to transmit the acknowledgment.

Press [CE] or select <Close> to return to the main interface.

◆ Distress Alert Relay Call

◇ Relaying the Distress Alert to All Ships.

a: Press [CALL] to open the call type list.

b: Use the [CH/ENT] knob to select <Relay Distress Alert to All Ships>, then press [ENT] to open the editing interface, as shown in Figure 4.2.1.

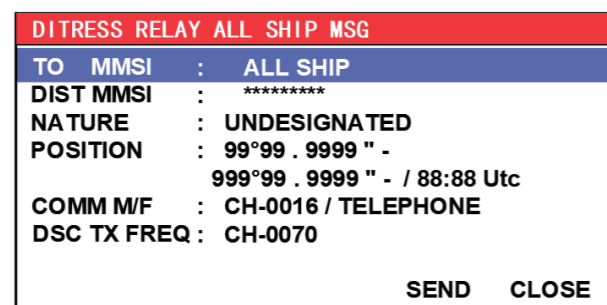

Figure 4.2.1

c: Rotate the [CH/ENT] knob to select <DIST MMSI>, then enter the distressed vessel's MMSI number using the numeric keypad. Alternatively, press [ENT] to open the address book and select the MMSI from saved contacts.

d: Rotate the [CH/ENT] knob to select <Nature>. Available types: Fire, Flooding, Collision, Grounding, Listing, Sinking, Adrift, Undesignated, Abandon, Piracy, Man Overboard (11 types). Press [ENT] to confirm.

e: Rotate the [CH/ENT] knob to select <Position>, then press [Number] to open the GNSS input dialog. Enter the correct GNSS coordinates, then press [ENT] to confirm.

f: Rotate the [CH/ENT] knob to select <Send>, then press [ENT] to transmit the distress alert relay call. Upon successful transmission, the device will automatically switch to CH16 for communication.

◇ Receiving a Distress Alert Relay to All Ship

Refer to Section 4.1.3 for distress alert call reception procedures.

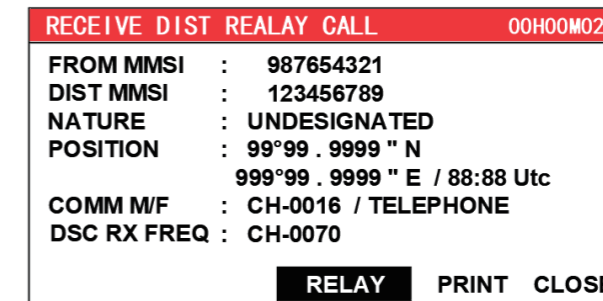

Figure 4.2.2

◇ Relaying a Distress Alert to an Individual Vessel

a: Press [CALL] to open the call type list.

b: Use the [CH/ENT] knob to select <Distress Relay Individual MSG >, then press [ENT] to open the editing interface, as shown in Figure 4.2.3.

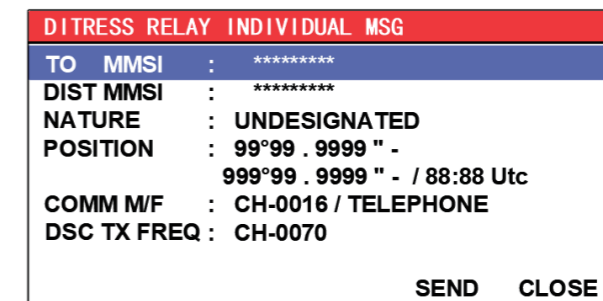

Figure 4.2.3

c: Rotate the [CH/ENT] knob to select <TO MMSI>, then enter the distressed vessel's MMSI number using the numeric keypad. Alternatively, press [ENT] to open the address book and select the MMSI from saved contacts.

d: Rotate the [CH/ENT] knob to select <DIST MMSI>, then enter the distressed vessel's MMSI number using the numeric keypad. Alternatively, press [ENT] to open the address book and select the MMSI from saved contacts.

- e: Rotate the [CH/ENT] knob to select <Nature>. Available distress types: Fire, Flooding, Collision, Grounding, Listing, Sinking, Adrift, Undesignated, Abandon, Piracy, Man Overboard (11 types). Press [ENT] to confirm.
- f: Rotate the [CH/ENT] knob to select <Position>, then press [Number] to open the GNSS input dialog. Enter the correct GNSS coordinates, then press [ENT] to confirm.
- g: Rotate the [CH/ENT] knob to select <Send>, then press [ENT] to transmit the distress alert relay call. After transmission, the device will switch to the waiting for acknowledgment interface and automatically jump to CH16 for communication.

◇ Receiving an Acknowledgment for a Distress Alert Relayed to an Individual Vessel

Refer to Section 4.1.2 for distress alert acknowledgment reception procedures.

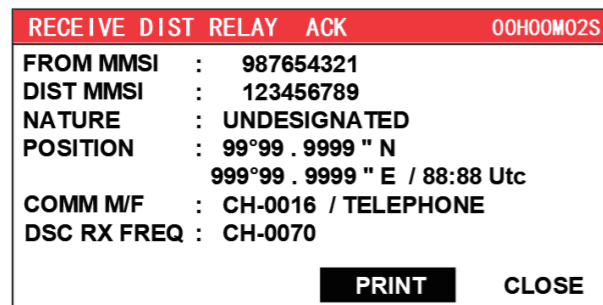

Figure 4.2.4

◇ Receiving a Distress Alert Relayed to an Individual Vessel

Refer to Section 4.1.3 for distress alert call reception procedures.

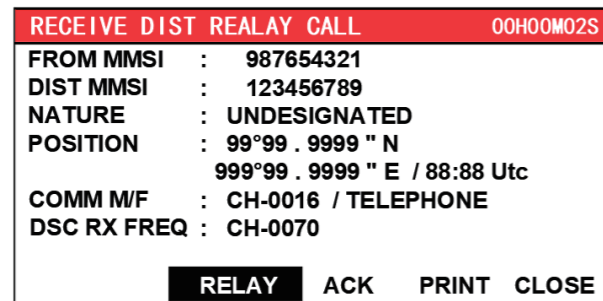

Figure 4.2.5

Routine Call Operation

※ DSC operation requires a valid MMSI number. If there is no valid MMSI number, pressing [DISTRESS] and [CALL] will trigger a warning message. The following operations assume the device has a valid MMSI number and is properly connected to the GNSS system.

◆ Individual Call

◇ Sending an Individual Call

- a: Press [CALL] to open the call type list.
- b: Use the [CH/ENT] knob to select <Individual Call>, then press [ENT] to open the editing interface, as shown in Figure 5.1.1.

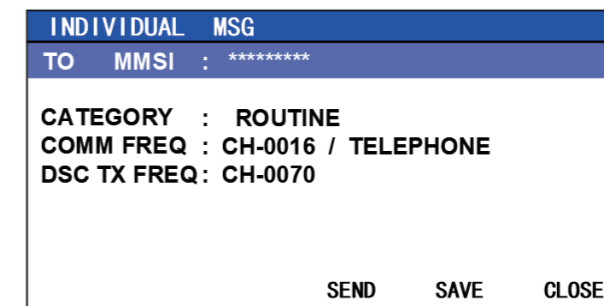

Figure 5.1.1

- c: Rotate the [CH/ENT] knob to select <TO MMSI>, then enter the target vessel's MMSI number using the numeric keypad. Alternatively, press [ENT] to open the address book and select the MMSI from saved contacts.
 - d: Rotate the [CH/ENT] knob to select <Category>, then press [ENT] to open the call priority list. Select the desired level and press [ENT] to confirm.
 - e: Rotate the [CH/ENT] knob to select <COMM FREQ>, then use the numeric keypad to enter the channel number.
 - f: Rotate the [CH/ENT] knob to select <Send>, then press [ENT] to transmit the call.
- After sending the call, the device will wait for an acknowledgment. Select <Resend>, then press [ENT] to send the call again.
- ※ Select <Save> to store the call in the call log.

◇ Receiving an Individual Call Acknowledgment

When the device receives an individual call acknowledgment, an alert sound will be triggered. The display will show the acknowledgment details, as illustrated in Figure 5.1.2. The device will switch to the communication channel and wait for conversation.

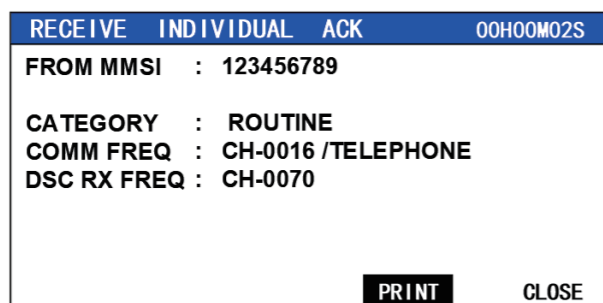

Figure 5.1.2

Select <Print> and press [ENT] to print the call details.
Select <Close> and press [ENT] to exit the interface and return to the main menu.

◇ Receiving an Individual Call

When the device receives an individual call, an alert sound will be triggered, and the display will show the call details, as illustrated in Figure 5.1.3.

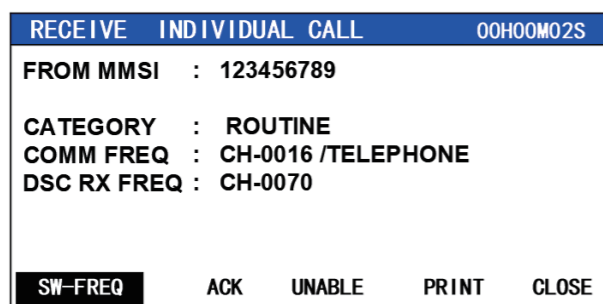

Figure 5.1.3

If the frequency conversion setting in the DSC menu is set to automatic mode, the device will automatically switch channels upon receiving the call.
If set to manual mode, the current channel will remain unchanged. The user must select <SW-FREQ> and press [ENT] to switch to the communication channel.

If acknowledgment is required, select <ACK> and press [ENT] to send the acknowledgment call. After transmission, the device will switch to CH16 for communication.

If unable to respond fully, select <Unable>, press [ENT] to open the response reason dialog, choose the appropriate reason, then press [ENT] to confirm and send the partial acknowledgment call. Upon completion, the device will return to the main menu.

Select <Print> and press [ENT] to print the call details.

Select <Close> and press [ENT] to exit the interface and return to the main menu.

◆ All Ship Call

◇ Sending an All Ship Call

a: Press [CALL] to open the call type list.

b: Use the [CH/ENT] knob to select <All Ship MSG>, then press [ENT] to open the editing interface, as shown in Figure 5.2.1.

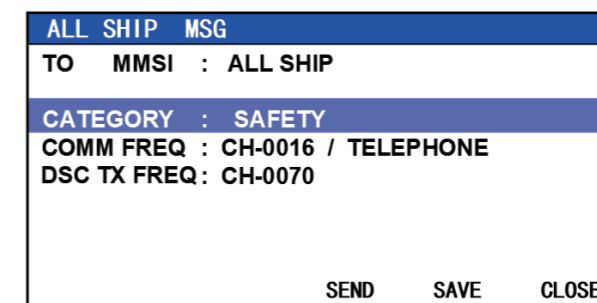

Figure 5.2.1

c: Rotate the [CH/ENT] knob to select <Category>, then press [ENT] to open the call priority list.

Select the desired level and press [ENT] to confirm.

d: Rotate the [CH/ENT] knob to select <COMM FREQ>, then use the numeric keypad to enter the channel number.

e: Rotate the [CH/ENT] knob to select <Send>, then press [ENT] to transmit the call.

f: After transmitting the call, the device will switch to CH16 for communication.

Select <RSEND> and press [ENT] to resend the call if necessary.

※ Select <Save> to store the call in the call log.

◇ Receiving an All Ship Call

When the device receives an All Ship Call, an alert sound will be triggered, and the display will show the call details, as illustrated in Figure 5.2.2.



Figure 5.2.2

If the frequency conversion setting in the DSC menu is set to automatic mode, the device will automatically switch channels upon receiving the call. If set to manual mode, the current channel will remain unchanged.

The user must select <SW-FREQ> and press [ENT] to switch to the communication channel.

Select <Print> and press [ENT] to print the call details.

Select <Close> and press [ENT] to exit the interface and return to the main menu.

◆ Group Call

◇ Sending a Group Call

a: Press [CALL] to open the call type list.

b: Use the [CH/ENT] knob to select <Group MSG>, then press [ENT] to open the editing interface, as shown in Figure 5.3.1.

c: Rotate the [CH/ENT] knob to select <TO MMSI>, then enter the group ID number using the numeric keypad. Alternatively, press [ENT] to open the address book and select the group ID from saved contacts.

d: Rotate the [CH/ENT] knob to select <Category>, then press [ENT] to open the call priority list.

Select the desired level and press [ENT] to confirm.

e: Rotate the [CH/ENT] knob to select <COMM FREQ>, then use the numeric keypad to enter the channel number.

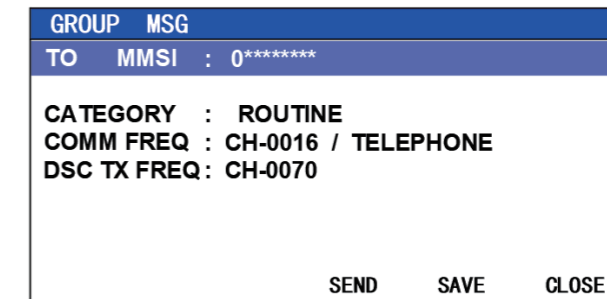

Figure 5.3.1

f: Rotate the [CH/ENT] knob to select <Send>, then press [ENT] to transmit the group call.

g: After transmitting the call, the device will switch to the communication channel and wait for conversation. Select <RSEND> and press [ENT] to resend the call if necessary.

※ The call category for a group call can only be set to routine.

※ Select <Save> to store the call in the call log.

◇ Receiving a Group Call

When the device receives a group call, an alert sound will be triggered, and the display will show the call details, as illustrated in Figure 5.3.2.



Figure 5.3.2

If the frequency conversion setting in the DSC menu is set to automatic mode, the device will automatically switch channels upon receiving the call. If set to manual mode, the current channel will remain unchanged. The user must select <SW-FREQ> and press [ENT] to switch to the communication channel.

Press [ENT] to switch to the communication frequency.
Select <Print> and press [ENT] to print the call details.
Select <Close> and press [ENT] to exit the interface and return to the main menu.

◆ PSTN Call

◇ Sending a PSTN Call

a: Press [CALL] to open the call type list.
b: Use the [CH/ENT] knob to select <PSTN MSG>, then press [ENT] to open the editing interface, as shown in Figure 5.4.1.

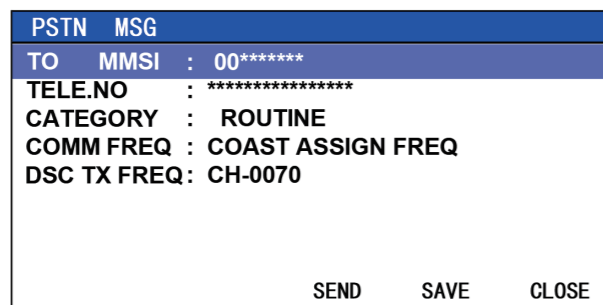

Figure 5.4.1

c: Rotate the [CH/ENT] knob to select <TO MMSI>, then enter the target vessel's MMSI number using the numeric keypad. Alternatively, press [ENT] to open the address book and select the MMSI from saved contacts.
d: Rotate the [CH/ENT] knob to select <TELE. No.>, then enter the destination phone number using the numeric keypad. Alternatively, press [ENT] to open the address book and select the phone number from saved contacts.
e: Rotate the [CH/ENT] knob to select <Send>, then press [ENT] to transmit the PSTN call request.
f: After sending the call, the device will wait for an acknowledgment.
Select <RSEND> and press [ENT] to resend the call if necessary.
※ Select <Save> to store the call in the call log.

◇ Receiving a PSTN Call Acknowledgment

When the device receives a PSTN call acknowledgment, an alert sound will be triggered, and the display will show the acknowledgment details, as illustrated in Figure 5.4.2.
The device will switch to CH16 for communication.



Figure 5.4.2

Select <Print> and press [ENT] to print the call details.
Select <Close> and press [ENT] to exit the interface and return to the main menu.

◇ Receiving a PSTN Call

When the device receives a PSTN call, an alert sound will be triggered, and the display will show the call details, as illustrated in Figure 5.4.3.

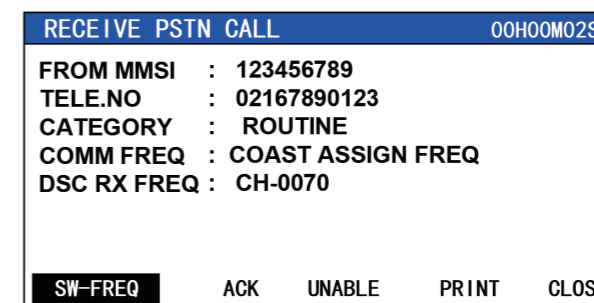

Figure 5.4.3

If the frequency conversion setting in the DSC menu is set to automatic mode, the device will automatically switch channels upon receiving the call. If set to manual mode, the current channel will remain unchanged. The user must select <SW-FREQ> and press [ENT] to switch to the communication channel.
If acknowledgment is required, select <ACK> and press [ENT] to send the acknowledgment call. After transmission, the device will switch to CH16 for communication.
If unable to respond fully, select <Unable>, press [ENT] to open the response reason dialog, choose the appropriate reason, then press [ENT] to confirm and send the partial acknowledgment call. Upon completion, the device will return to the main menu.
Select <Print> and press [ENT] to print the call details.
Select <Close> and press [ENT] to exit the interface and return to the main menu.

◆ Position Call

◇ Sending a Position Call

- a: Press [CALL] to open the call type list.
- b: Use the [CH/ENT] knob to select <Position MSG>, then press [ENT] to open the editing interface, as shown in Figure 5.5.1.



Figure 5.5.1

- c: Rotate the [CH/ENT] knob to select <TO MMSI>, then enter the target vessel's MMSI number using the numeric keypad. Alternatively, press [ENT] to open the address book and select the MMSI from saved contacts.
- d: Rotate the [CH/ENT] knob to select <Send>, then press [ENT] to transmit the position call.
- e: After sending the call, the device will wait for an acknowledgment.
Select <RESEND> and press [ENT] to resend the call if necessary.
※ Select <Save> to store the call in the call log.

◇ Receiving a Position Call Acknowledgment

When the device receives a position call acknowledgment, an alert sound will be triggered, and the display will show the acknowledgment details, as illustrated in Figure 5.5.2.

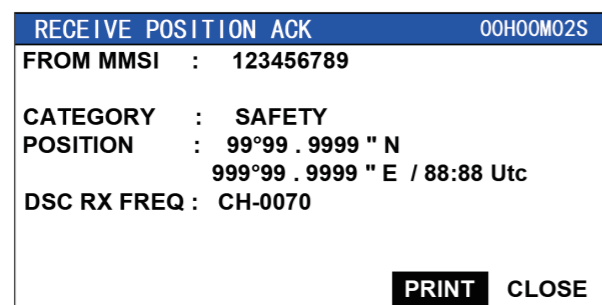

Figure 5.5.2

- Select <Print> and press [ENT] to print the call details.
- Select <Close> and press [ENT] to exit the interface and return to the main menu.

◇ Receiving a Position Call

When the device receives a Position Call, an alert sound will be triggered, and the display will show the call details, as illustrated in Figure 5.5.3.

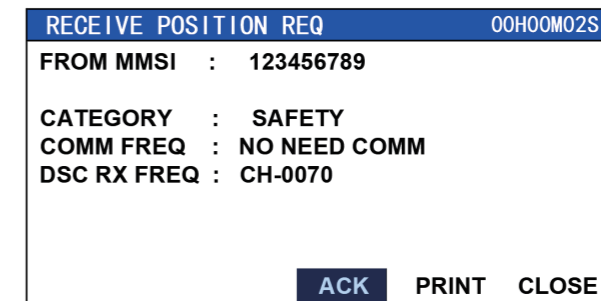

Figure 5.5.3

- Select <ACK> and press [ENT] to send an acknowledgment call.
- Select <Print> and press [ENT] to print the call details.
- Select <Close> and press [ENT] to exit the interface and return to the main menu.

◆ Test Call

◇ Sending a Test Call

- a: Press [CALL] to open the call type list.
- b: Use the [CH/ENT] knob to select <Test MSG>, then press [ENT] to open the editing interface, as shown in Figure 5.6.1.
- c: Rotate the [CH/ENT] knob to select <TO MMSI>, then enter the target vessel's MMSI number using the numeric keypad. Alternatively, press [ENT] to open the address book and select the MMSI from saved contacts.
- d: Rotate the [CH/ENT] knob to select <Send>, then press [ENT] to transmit the test call.
- e: After sending the call, the device will wait for an acknowledgment. Select <RESEND> and press [ENT] to resend the call if necessary.
※ Select <Save> to store the call in the call log.



Figure 5.6.1

◇ Receiving a Test Call Acknowledgment

When the device receives a test call acknowledgment, an alert sound will be triggered, and the display will show the acknowledgment details, as illustrated in Figure 5.6.2.

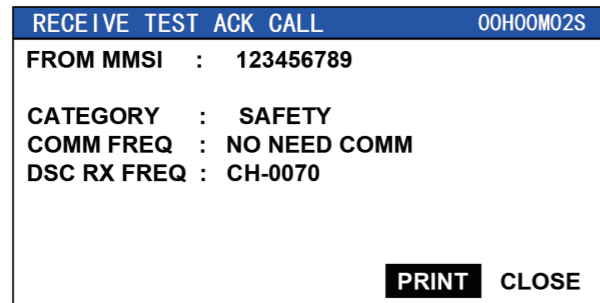

Figure 5.6.2

Select <Print> and press [ENT] to print the call details.
Select <Close> and press [ENT] to exit the interface and return to the main menu.

◇ Receiving a Test Call

When the device receives a test call, an alert sound will be triggered, and the display will show the call details, as illustrated in Figure 5.6.3.

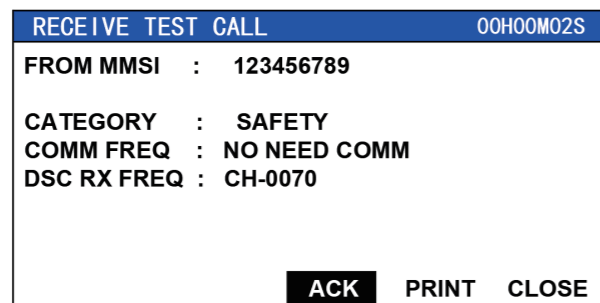

Figure 5.6.3

Select <ACK> and press [ENT] to send an acknowledgment call.
Select <Print> and press [ENT] to print the call details.
Select <Close> and press [ENT] to exit the interface and return to the main menu.

◆ DSC Call

Refer to Section 5.1 for details on individual call operation. In the call type list, select <DSC MSG>.

◆ Neutral Craft Call

※ Neutral Craft Calls can only be sent if special call functionality is enabled on the device.
For instructions on enabling special calls, refer to the menu operation section.
Refer to Section 5.2 for details on All Ship MSG operations. In the call type list, select <Neutral Craft Call>.
Neutral Craft Calls are only classified as emergency calls.

◆ Medical Transport Call

※ Medical Transport Calls can only be sent if special call functionality is enabled on the device.
For instructions on enabling special calls, refer to the menu operation section.
Refer to Section 5.2 for details on All Ship MSG operations. In the call type list, select <Medical Transport Call>.
Medical Transport Calls are only classified as emergency calls.

◆ Polling Call

※ The device only receives Polling Calls.
When the device receives a Polling Call, an alert sound will be triggered, and the display will show the call details, as illustrated in Figure 5.10.1.

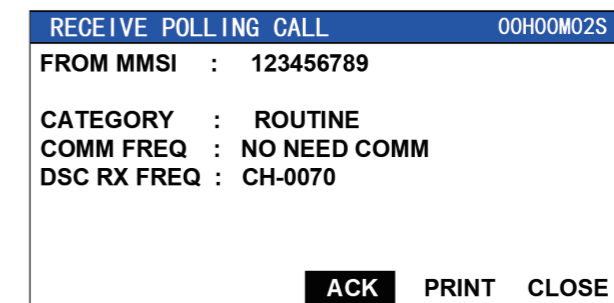

Figure 5.10.1

Select <ACK> and press [ENT] to send an acknowledgment call.
Select <Print> and press [ENT] to print the call details.
Select <Close> and press [ENT] to exit the interface and return to the main menu.

Menu Operations

◆ Using the Menu

Press [MENU] on the panel to open the main menu. Rotate the CH/ENT knob to select a submenu or operation item, then press [ENT] to confirm and enter the submenu. Press [CE] to return to the previous menu.

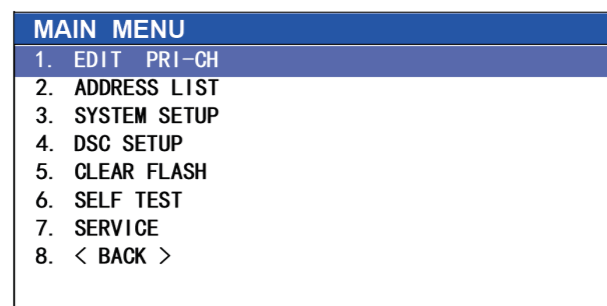

Figure 6.1

◆ Editing User Channels

The device supports up to 100 user channels, which must be configured with correct transmission and reception frequencies before use.

How to Edit User Channels

- a: In the main menu, select <Edit PRI-CH>, then press [ENT] to open the channel information list.
 - b: Select the channel number to edit, then press [ENT] to open the channel operation dialog.
- As shown in Figure 6.2.1, select <Edit Select Channel> and press [ENT] to open the editing interface.

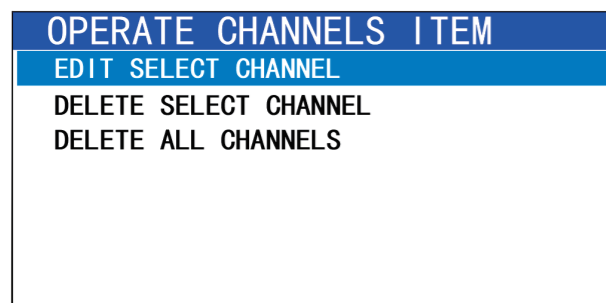

Figure 6.2.1

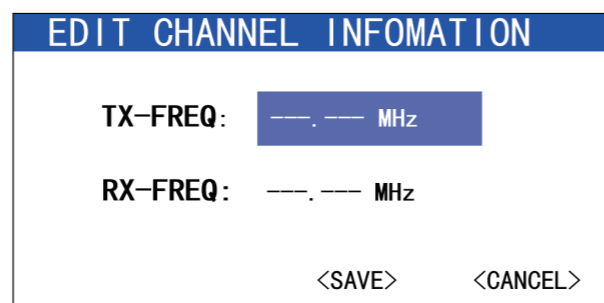

Figure 6.2.2

c: Use the numeric keypad to enter the transmission and reception frequency, then rotate the CH/ENT knob to select <Save> and press [ENT] to confirm.

Deleting User Channels:

In the channel operation dialog opened in Step b, rotate the CH/ENT knob to select either <Delete Select Channel> or <Delete All Channels>, then press [ENT] to remove the corresponding channel.

※ The transmission/reception frequency for user channels must be within the maritime frequency range and divisible by 25 kHz.

◆ Address Book

The device allows the operator to store up to 20 vessel MMSI numbers, 20 shore station MMSI numbers, 20 group MMSI numbers, and 20 phone numbers for convenient call input.

Adding/Editing an Entry:

- a: In the main menu, select <Address List> and press [ENT] to open the contact list.
- b: Rotate the CH/ENT knob to select the entry to edit, then press [ENT] to open the entry operation dialog, as shown in Figure 6.3.1.

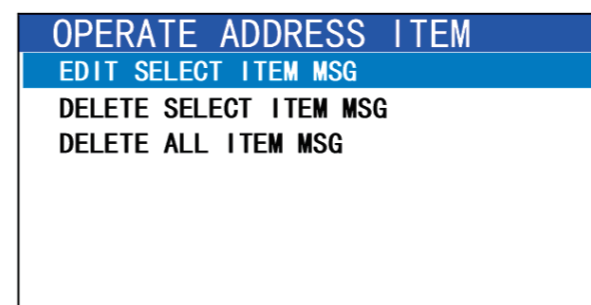

Figure 6.3.1

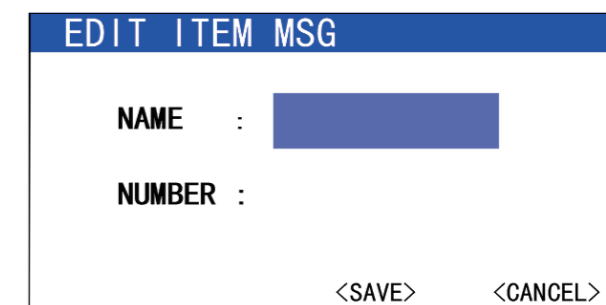

Figure 6.3.2

c: Rotate the CH/ENT knob to select <Edit Select Item MSG>, then press [ENT] to open the editing interface. Use the numeric keypad to enter the entry name and number.

d: Once the information is entered, rotate the CH/ENT knob to <Save> and press [ENT] to confirm.

Deleting an Entry:

In the entry operation dialog opened in Step b, rotate the CH/ENT knob to select either <Delete Selected Item MSG> or <Delete All Item MSG>, then press [ENT] to remove the corresponding entry.

◆ System Settings

In the main menu, select <System Setup> and press [ENT] to open the system settings menu.

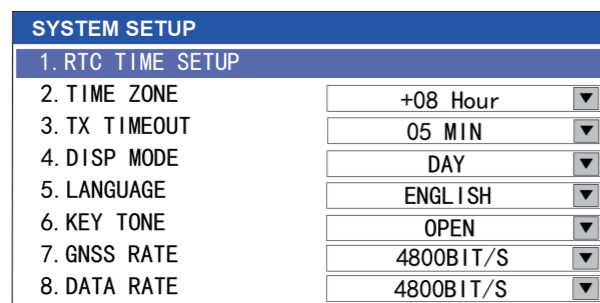

Figure 6.4

The system settings menu includes:

1. RTC Time Setup [RTC TIME SETUP]
2. Time Zone [TIME ZONE]
3. Transmission Timeout [TX TIMEOUT]
4. Display Mode [DISP MODE]
5. Language [LANGUAGE]
6. Key Tone [KEY TONE]
7. GNSS Baud Rate [GNSS RATE]
8. Data Baud Rate (Serial Printer Interface) [DATA RATE]

Rotate the CH/ENT knob to select the desired setting, then press [ENT] to open the corresponding configuration list. In the configuration list, rotate the CH/ENT knob to select the desired value, then press [ENT] to confirm.

◇ RTC Time Setup

The device is equipped with an RTC module to generate local date and time.

How to Set the Internal RTC:

a: In the system settings menu, select <RTC Time Setup> and press [ENT] to open the RTC setup dialog, as shown in Figure 6.4.1.

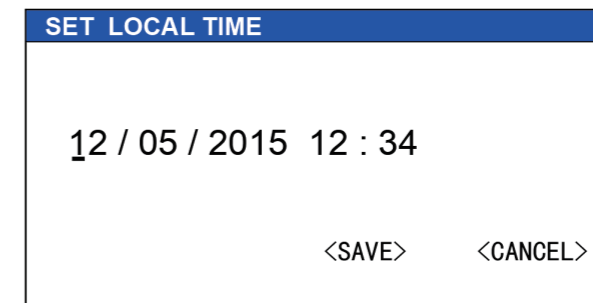

Figure 6.4.1

b: Use the numeric keypad to enter the date and time information. Alternatively, rotate the CH/ENT knob to move the cursor and adjust the digits at the selected position. Once the entry is complete, rotate the CH/ENT knob to select <Save> and press [ENT] to confirm the time settings.

◆ DSC Settings

◇ Local MMSI Setup

The device allows users to modify the local MMSI number up to three times. After exceeding three changes, a modification password is required to continue changing the MMSI number.

a: In the <DSC Setup> menu, select <MMSI Setup>, then press [ENT] to open the local MMSI setup dialog, as shown in Figure 6.5.1.

b: Use the numeric keypad to enter the MMSI number. Rotate the CH/ENT knob to move the cursor and adjust the digits at the selected position. Once the entry is complete, rotate the CH/ENT knob to select <Save> and press [ENT] to confirm.

c: Press [ENT] to return to the DSC settings menu.



Figure 6.5.1

◇ Viewing Call Logs

The device can store up to 20 pre-edited routine calls, transmitted and received distress calls, and routine calls per category.

- a: In the <DSC Setup> menu, select <DSC LOG View> and press [ENT], or press [LOG] on the front panel to open the call log list.
- b: Rotate the CH/ENT knob to select the call log type to view, then press [ENT] to open the corresponding call log file list.
- c: Rotate the CH/ENT knob to select the call to operate, then press [ENT] to open the call log operation dialog, as shown in Figure 6.5.2.

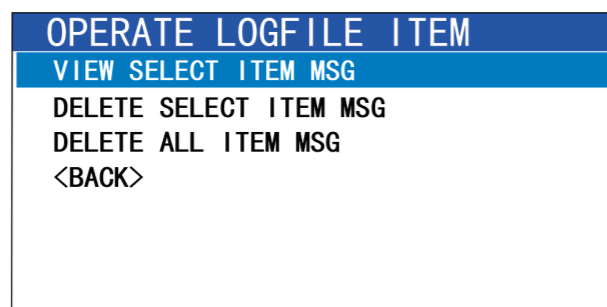

Figure 6.5.2

- d: Rotate the CH/ENT knob to select the desired operation (View, Delete).
- e: Press [CE] to exit the call log list.

◇ Position Setup

When the device is not connected to an external GNSS, users can manually enter GNSS information.

- a: In the <DSC Setup> menu, select <Position Setup> and press [ENT] to open the GNSS setup dialog, as shown in Figure 6.5.3.
- b: Use the numeric keypad to enter GNSS information. Rotate the CH/ENT knob to move the cursor and adjust the digits at the selected position. Once the entry is complete, rotate the CH/ENT knob to select <SAVE> and press [ENT] to confirm.
- c: Press [ENT] to return to the <DSC Setup> menu.

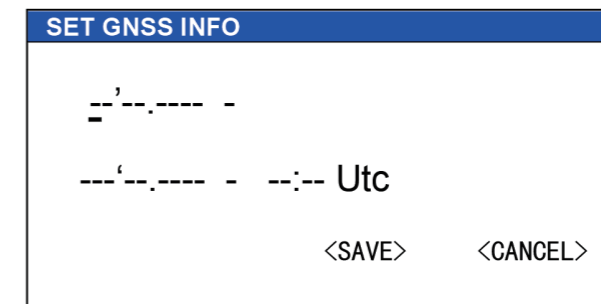

Figure 6.5.3

◇ Acknowledgment Settings

The device allows users to configure the acknowledgment mode for calls. By default, all calls require manual acknowledgment.

- a: In the <DSC Setup> menu, select <ACK Setup>, then press [ENT] to open the acknowledgment settings dialog, as shown in Figure 6.5.4.1.
- b: Rotate the CH/ENT knob to select the call type to configure, then press [ENT] to open the acknowledgment mode list, as shown in Figure 6.5.4.2.
- c: Rotate the CH/ENT knob to select the desired acknowledgment mode, then press [ENT] to confirm.

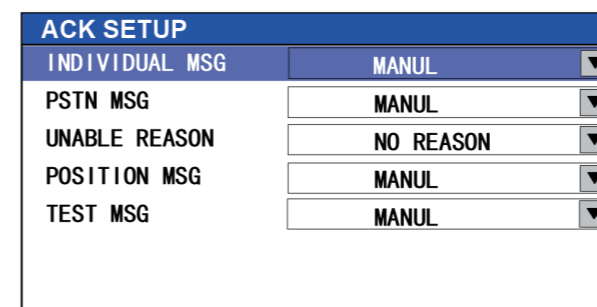

Figure 6.5.4.1

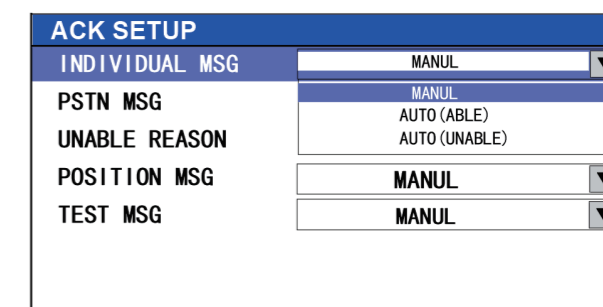

Figure 6.5.4.2

- d: Press [CE] to return to the <DSC Setup> menu.
- ※ If the acknowledgment mode is set to automatic acknowledgment (UNABLE), users must specify the UNABLE reason.

◇ **Printing Settings**

The device supports connection to a serial printer (specific models required—please consult the supplier).

Call information can be printed upon sending or receiving a call.

Users can set the print mode to either automatic or manual. The default setting is manual printing.

a: In the <DSC Setup> menu, select <Printing Setup>, then press [ENT] to open the printing settings dialog, as shown in Figure 6.5.5.1.

b: Rotate the CH/ENT knob to select the call type to configure, then press [ENT] to open the status list, as shown in Figure 6.5.5.2.

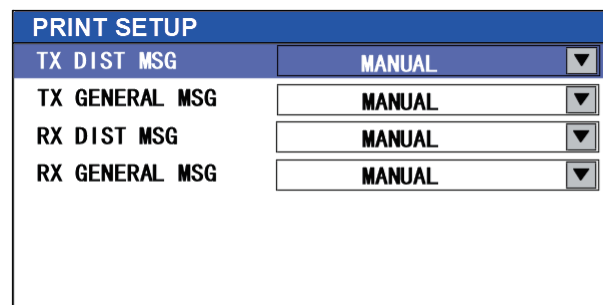

Figure 6.5.5.1

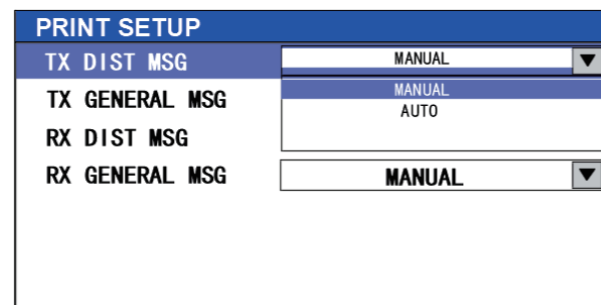

Figure 6.5.5.2

c: Rotate the CH/ENT knob to select the preferred printing mode, then press [ENT] to confirm.

d: Press [CE] to return to the <DSC Setup> menu.

◇ **Frequency Conversion Settings**

When receiving a routine call, the device allows users to configure the communication channel switching mode, either automatic or manual .

The default setting is automatic switching.

a: In the <DSC Setup> menu, select <Switch Setup>, then press [ENT] to open the frequency conversion settings dialog, as shown in Figure 6.5.6.1.

b: Rotate the CH/ENT knob to select the call priority level, then press [ENT] to open the conversion mode list, as shown in Figure 6.5.6.2.

c: Rotate the CH/ENT knob to select the preferred conversion mode, then press [ENT] to confirm.

d: Press [CE] to return to the <DSC Setup> menu.

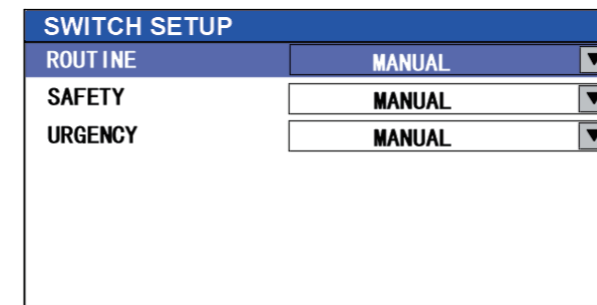

Figure 6.5.6.1

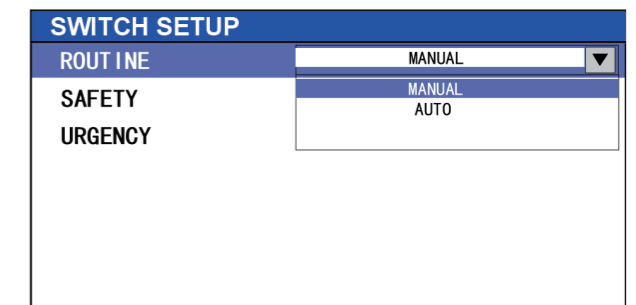

Figure 6.5.6.2

◇ **Special Call Settings**

Special calls include Neutral Craft Call and Medical Transport Call . By default, special calls are disabled, but users can enable them in this menu.

a: In the <DSC Setup> menu, select <Special Setup>, then press [ENT] to open the special call settings dialog, as shown in Figure 6.5.7.1.

b: Rotate the CH/ENT knob to select the call type to configure, then press [ENT] to open the special call status list, as shown in Figure 6.5.7.2.

c: Rotate the CH/ENT knob to select the enable status for special calls, then press [ENT] to confirm.

d: Press [CE] to return to the <DSC Setup> menu.

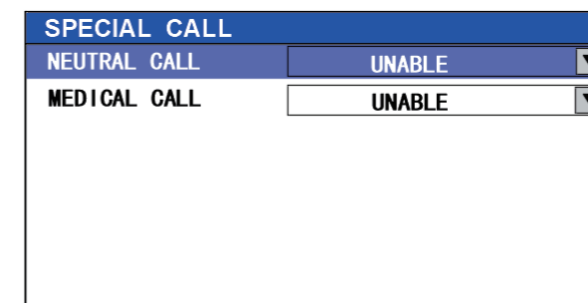

Figure 6.5.7.1

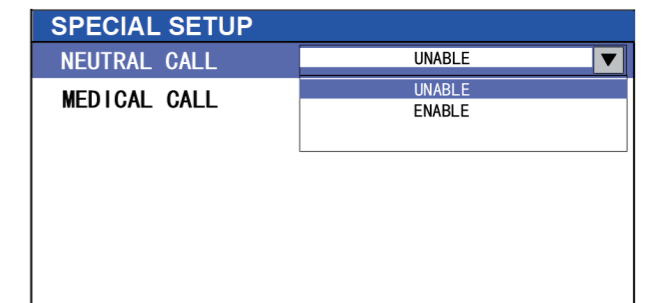

Figure 6.5.7.2

◆ Memory Reset

If the device settings are incorrect or require a full reset, this function can be used. Selecting <Clear Memory> in the main menu will erase all user-configured data, including menu settings, user channel frequencies, and address book entries.

- a: In the main menu, select <Clear Flash> and press [ENT] to open the factory reset dialog.
- b: Rotate the CH/ENT knob to select <ENTER>, then press [ENT] to clear all user data stored in memory.
- c: Press [CE] to return to the main menu.

◆ Self-Test

The device includes a self-test function to verify the operational status of reception, transmission, DSC, and memory.

- a: In the main menu, select <Self Test> and press [ENT] to start the self-test process.
- b: Once the self-test is complete, press [ENT] or [CE] to return to the main menu.

◆ Service Information

Displays the device serial number, current hardware version, software version, and factory date.

- a: In the main menu, select <Service > and press [ENT] to open the service information dialog.
- b: Press [CE] to return to the main menu.

GNSS Device Connection

The FT-1101 GNSS interface supports connection to GNSS receivers with RS232 or RS422 output. The communication baud rate is configurable—refer to the menu operation section for details. The FT-1101 processes GNSS data formatted in NMEA 0183 version 2.0, including RMC, GGA, GLL, ZDA, and GNS sentences.

When the device successfully connects to a GNSS receiver and receives valid GNSS data, the screen displays "-- AUTO INPUT --".

If the GNSS connection is lost for 30 seconds, the device retains the last received GPS information, and the screen displays "-- Lost - 30s --".

If GNSS data remains unrefreshed for 4 hours, the screen displays "-- Lost - 4hour --" and a warning prompt appears, as illustrated in Figure 7.1. Press [CE] to dismiss the warning prompt.

If GNSS data remains unrefreshed for 23.5 hours, the screen displays "-- Lost - 23.5hour --", and a warning prompt appears, as illustrated in Figure 7.2. At this point, the GNSS data is set to default invalid values. Press [CE] to dismiss the warning prompt.

※ The default invalid GNSS data consists of all latitude/longitude digits set to '9' and UTC time digits set to '8'.

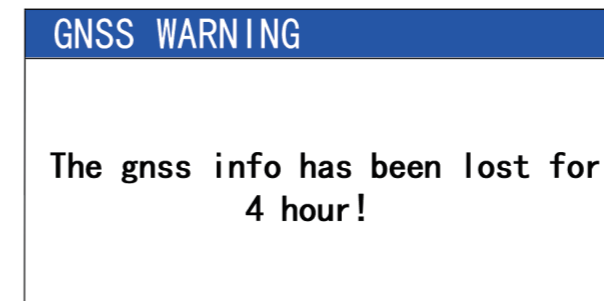

Figure 7.1

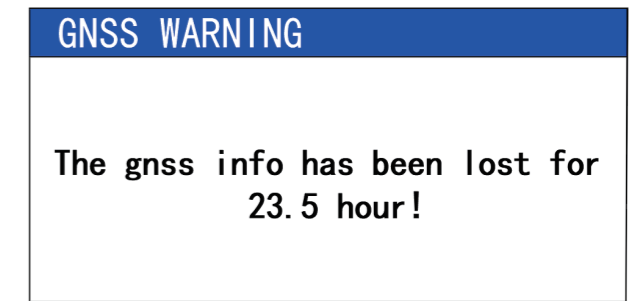
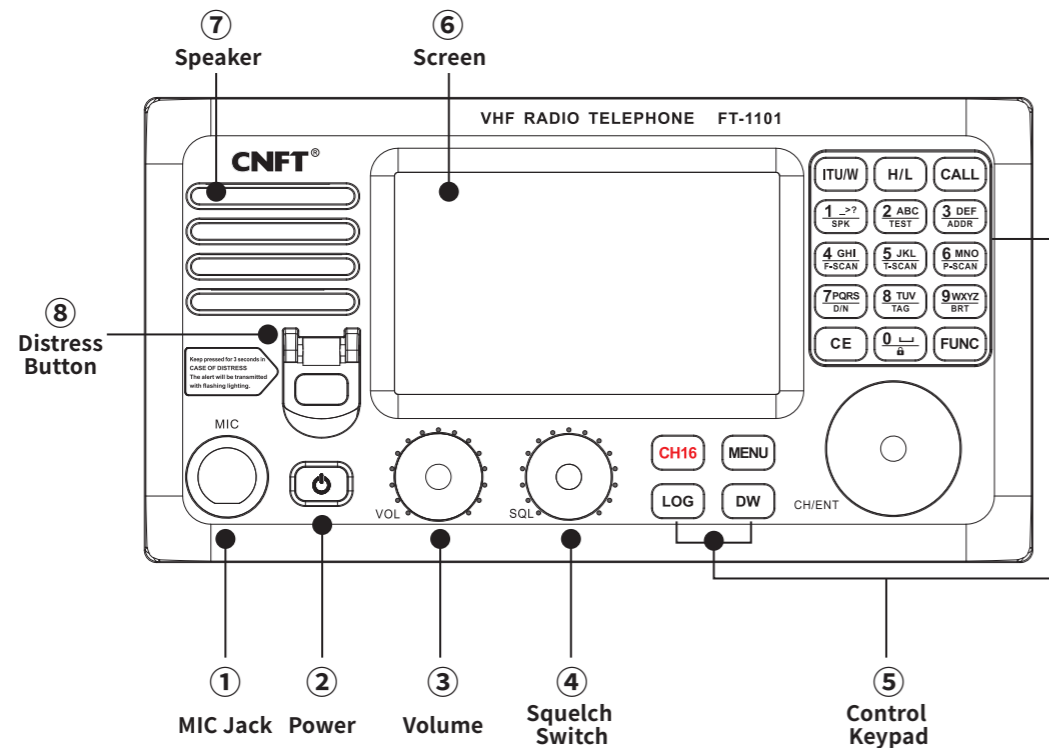

Figure 7.2

Interface Specification

Front View



Rear View

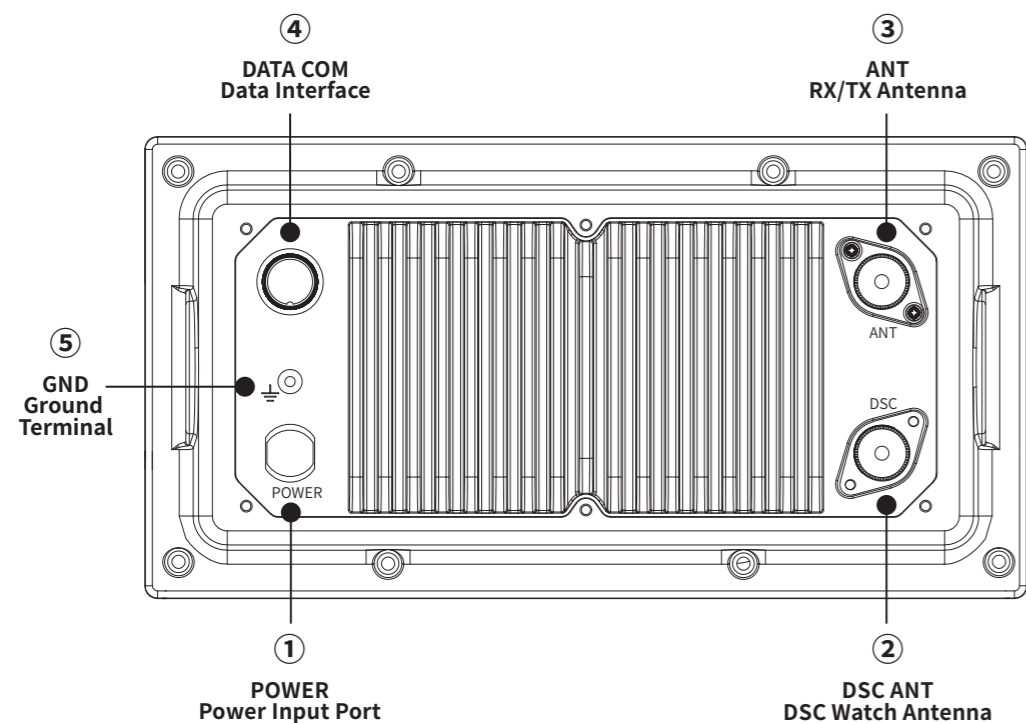

Rear Interface Specifications

① POWER(Power Input Connector)

※Note: Rated Input: DC 12V, Operating Range: 10.8V-15.6V, Min Current: 5A

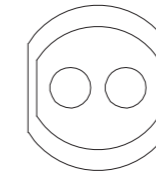

Red: Power Input Terminal (+)
Black: Power Input Terminal (-)

② DSC ANT(DSC Watch Antenna Interface)

③ ANT(RX/TX Antenna Interface)

④ DATA COM(Data Communication Interface)

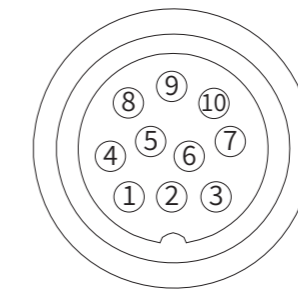

No.	Definition	Function
1	VDR_A	Voyage Data Output A
2	GND	Ground
3	GNSS_RX+	Positioning Input (+)
4	EXT_ALARM+	Alarm Interface (+)
5	EXT_ALARM-	Alarm Interface (-)
6	VDR_B	Voyage Data Output B
7	GNSS_RX-	Positioning Input (-)
8	RS232_WXD	Printer Output
9	EXP_SPK-	Audio Output (-)
10	EXP_SPK+	Audio Output (+)

⑤ GND(System Ground Terminal)

Appendix

◆ Appendix A: USA Frequency Bands Table (USA)

Channel	Frequency (MHz)		Channel	Frequency (MHz)	
	Transmission	Reception		Transmission	Reception
1001	156.050	156.050	60		
2			61		
3			62		
4			1063	156.175	156.175
1005	156.250	156.250	64		
6	156.300	156.300	1065	156.275	156.275
1007	156.350	156.350	1066	156.325	156.325
8	156.400	156.400	67 *L	156.375	156.375
9	156.450	156.450	68	156.425	156.425
10	156.500	156.500	69	156.475	156.475
11	156.550	156.550	70 *D	156.525	156.525
12	156.600	156.600	71 *L	156.575	156.575
13 *L	156.650	156.650	72	156.625	156.625
14	156.700	156.700	73	156.675	156.675
15	*RX only	156.750	74	156.725	156.725
16	156.800	156.800	75		
17 *L	156.850	156.850	76		
1018	156.900	156.900	77 *L	156.875	156.875
1019	156.950	156.950	1078	156.925	156.925
20	157.000	161.600	1079	156.975	156.975
1020	157.000	157.000	1080	157.025	157.025
1021	157.050	157.050	1081	157.075	157.075
1022	157.100	157.100	1082	157.125	157.125
1023	157.150	157.150	1083	157.175	157.175
24	157.200	161.800	84	157.225	161.825
25	157.250	161.850	85	157.275	161.875
26	157.300	161.900	86	157.325	161.925
27	157.350	161.950	87	157.375	157.375
28	157.400	162.000	88	157.425	157.425

*L: Low Power Only * D: DSC Band *RXonly: TX Prohibited

◆ Appendix B: International Frequency Bands Table (INT)

Channel	Frequency (MHz)		Channel	Frequency (MHz)	
	Transmission	Reception		Transmission	Reception
1	156.050	160.650	60	156.025	160.625
2	156.100	160.700	61	156.075	160.675
3	156.150	160.750	62	156.125	160.725
4	156.200	160.800	63	156.175	160.775
5	156.250	160.850	64	156.225	160.825
6	156.300	156.300	65	156.275	160.875
7	156.350	160.950	66	156.325	160.925
8	156.400	156.400	67	156.375	156.375
9	156.450	156.450	68	156.425	156.425
10	156.500	156.500	69	156.475	156.475
11	156.550	156.550	70 *D	156.525	156.525
12	156.600	156.600	71	156.575	156.575
13	156.650	156.650	72	156.625	156.625
14	156.700	156.700	73	156.675	156.675
15 *L	156.750	156.750	74	156.725	156.725
16	156.800	156.800	75 *L	156.775	156.775
17 *L	156.850	156.850	76 *L	156.825	156.825
18	156.900	161.500	77	156.875	156.875
19	156.950	161.550	78	156.925	161.525
1019	156.950	156.950	1078	156.925	156.925
2019	*RX only	161.550	2078	*RX only	161.525
20	157.000	161.600	79	156.975	161.575
1020	157.000	157.000	1079	156.975	156.975
2020	*RX only	161.600	2079	RX only	161.575
21	157.050	161.650	80	157.025	161.625
22	157.100	161.700	81	157.075	161.675
23	157.150	161.750	82	157.125	161.725
24	157.200	161.800	83	157.175	161.775
25	157.250	161.850	84	157.225	161.825
26	157.300	161.900	85	157.275	161.875
			86	157.325	161.925
1027	157.350	157.350	87	157.375	157.375
1028	157.400	157.400	88	157.425	157.425

*L: Low Power Only * D: DSC Band *RXonly: TX Prohibited

◆ Appendix C: Canada Frequency Bands Table (CAN)

Channel	Frequency (MHz)		Channel	Frequency (MHz)	
	Transmission	Reception		Transmission	Reception
1001	156.050	156.050	60		
2			61		
3			62		
4			1063	156.175	156.175
1005	156.250	156.250	64		
6	156.300	156.300	1065	156.275	156.275
1007	156.350	156.350	1066	156.325	156.325
8	156.400	156.400	67 *L	156.375	156.375
9	156.450	156.450	68	156.425	156.425
10	156.500	156.500	69	156.475	156.475
11	156.550	156.550	70 *D	156.525	156.525
12	156.600	156.600	71 *L	156.575	156.575
13 *L	156.650	156.650	72	156.625	156.625
14	156.700	156.700	73	156.675	156.675
15	*RX only	156.750	74	156.725	156.725
16	156.800	156.800	75		
17 *L	156.850	156.850	76		
1018	156.900	156.900	77 *L	156.875	156.875
1019	156.950	156.950	1078	156.925	156.925
20	157.000	161.600	1079	156.975	156.975
1020	157.000	157.000	1080	157.025	157.025
1021	157.050	157.050	1081	157.075	157.075
1022	157.100	157.100	1082	157.125	157.125
1023	157.150	157.150	1083	157.175	157.175
24	157.200	161.800	84	157.225	161.825
25	157.250	161.850	85	157.275	161.875
26	157.300	161.900	86	157.325	161.925
27	157.350	161.950	87	157.375	157.375
28	157.400	162.000	88	157.425	

*L: Low Power Only * D: DSC Band *RXonly: TX Prohibited *CH20xx is equivalent to CHxxB

◆ Appendix D: Weather Frequency Bands Table (WX)

Channel	Frequency (MHz)	
	Transmission	Reception
01	*RX only	162.550
02	*RX only	162.400
03	*RX only	162.475
04	*RX only	162.425
05	*RX only	162.450
06	*RX only	162.500
07	*RX only	162.525
08	*RX only	161.650
09	*RX only	161.775
10	*RX only	163.275
11	*RX only	149.225
12	*RX only	149.850
13	*RX only	160.650

*RXonly: TX Prohibited

Maintenance

Phenomenon	Potential Cause	Corrective Action
Cannot Power On	Power leads reversed; power cord not fully inserted; input voltage over-range	Check and correct power wiring polarity; fully insert power cord; ensure input voltage is within the specified range
Insufficient Transmit Power	Improper antenna installation (loose or misaligned); nearby obstructions	Reinstall antenna securely at the correct angle; remove any nearby obstructions
Weak or No Receive Signal	Antenna improperly connected; antenna entangled with foreign objects	Verify and reconnect the antenna; clear any debris or tangles around the antenna
Excessive Channel Noise	Unit not grounded; interference from nearby electrical equipment	Properly ground the unit; relocate it away from noise-generating devices

◇ Periodic Inspection

Please perform the following checks regularly to maintain optimal performance.

Item	Issue	Action
Power Cable	Exposed or damaged	Replace
Power Plug	Loose	Secure
Display Panel	Corroded	Clean
Supply Voltage	Over-voltage or under-voltage	Check power system

◇ Cleaning

Dust and stains on the instrument's surface can be wiped away with a soft cloth. If necessary, a dampened soft cloth may be used. Exercise extra care when cleaning the LCD, as it is easily scratched.

Do not use chemical cleaners, as they may remove paint or markings from the instrument's surface.

安全提示

⚠ 危险!

- 若有物品掉入设备或水溅入设备, 立即关闭配电板电源。(继续使用可能引发火灾或触电)
- 若设备冒烟或起火, 立即关闭配电板电源。(继续使用可能引发火灾或触电)
- 若设备运行异常, 立即关闭配电板电源。(继续使用可能引发火灾或触电, 建议联系代理商/经销商咨询)

⚠ 警告!

- 开始安装前, 务必关闭配电板电源。板电源。(安装过程中通电可能引发火灾或触电)
- 仅使用指定电源线。(使用其他电缆可能引发火灾或触电)
- 请勿在设备可能被雨水或溅水打湿的位置安装。(水进入设备内部可能引发火灾或触电)
- 请勿将盛有液体的容器放置在设备顶部。(可能引发火灾或触电)
- 请勿用湿手操作设备。(可能引发触电)
- 请勿拆卸或改装设备。(可能引发触电、火灾或人身伤害)

⚠ 警告!

- 除非完全熟悉电气电路, 否则请勿在设备内部作业。
- 设备内部存在可能导致触电的危险电压。

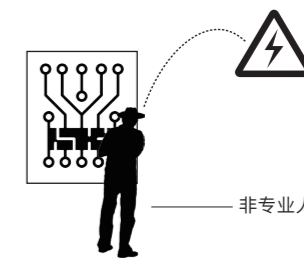

- 开始安装前, 请关闭主配电板上的电源。在开关附近张贴标志, 表明设备安装期间不应打开电源。如果设备安装期间电源未关闭或接通, 可能会导致火灾、触电或重伤。



- 除非船舶真正遇险, 否则请勿操作遇险按钮。(操作遇险按钮会发送遇险信号; 若意外发送, 需立即联系海岸电台报告)

⚠ 注意!

- 确认电源电压与设备的额定电压兼容。连接错误的电源可能会导致火灾或设备损坏。额定电压显示在显示单元背面的标签上。
- 小心使用接地铜带其边缘可能会伤到您的手。
- 请保持以下罗盘安全距离60MM以上。
- 接地设备: 未接地的设备可能会发出或收电磁干扰, 或导致触电。



目录

安全提示.....	48	■ 电话呼叫	71
前言.....	50	■ 位置请求呼叫	73
主要技术指标.....	50	■ 测试呼叫	74
安全说明.....	51-56	■ 数据呼叫	75
■ 电气安装.....	51	■ 中立船呼叫	76
■ 固定安装.....	52	■ 医疗船呼叫	76
■ 天线安装.....	56	■ 查询呼叫	76
面板说明.....	57-58	菜单操作.....	77-85
■ 前面板布局.....	57	■ 如何使用菜单	77
■ 显示界面.....	58	■ 编辑用户频道	77
基本操作.....	59-60	■ 通讯录	78
■ 如何开关机	59	■ 系统设置	79
■ 如何转换频道	59	■ 数字选呼设置	80
■ 如何进行无线电发射和接收.....	59	■ 清空存储器	85
■ 如何进行双看守.....	59	■ 自检测试	85
■ 如何进行全频道扫描.....	59	■ 服务信息.....	85
■ 如何标记/记忆当前频道.....	60	GNSS设备连接.....	86
■ 如何标记/记忆当前频道扫描.....	60	系统接口规格说明.....	87-88
■ 如何进行优先频道扫描.....	60	■ 显示单元前视图说明	87
■ 如何切换显示模式.....	60	■ 显示单元后视图说明	87
■ 如何调节按键背光亮度.....	60	■ 显示单元后视图接口规格	88
遇险报警呼叫操作.....	61-65	附录.....	90-93
■ 遇险报警呼叫	61	■ 美国频段频率表	90
■ 遇险报警呼叫转发	63	■ 国际频段频率表	91
普通呼叫操作.....	66-76	■ 加拿大频段频率表	92
■ 单台呼叫	66	■ 天气频段频率表	93
■ 所有台呼叫	68	设备维护.....	94
■ 群组呼叫	69		

前言

感谢您选用本公司研制的产品,型号:FT-1101 名称:甚高频(A级DSC)无线电装置。产品包括主机以及随机配置附件,请参看产品《装箱清单表》。在安装使用产品前,请务必仔细阅读《产品使用说明书》,避免人员不专业、错误操作引起设备损坏或人身安全,本公司不承担由此引起的一切后果责任。

※注:若产品升级更新导致《产品使用说明书》与设备实际操作使用不一致,请以设备为准。

主要技术指标

项目名称	技术参数
电源	DC 12V +30/-10%
频道容量	57个国际海事频道并且扩展100个私有频道
频率宽带	25KHz
频率生成方法	频率合成
无线电接收机	采用双变换超外差设计,多频道接收
	频率范围: 156.025Mhz~163.275Mhz
	IF用频率: 21.7MHz;450KHz; 最大可用灵敏度: ≤6dBμV(e.m.f.) of 20dB/SINAD
	邻频选择: ≥70dB; 寄生信号干扰: ≥70dB
	互调干扰: ≥65dB
	寄生辐射: ≤2nW
	电流: 0.9Amps(MaxAudio),0.4Amps (STBY)
70频道DSC接收机	音频频率响应: +1, -3dB of +6dB/octave (300-3000Hz)
	噪音: ≤-40dB; 音频输出: 2W(8Ohm,少于 10% 失真)
	频率: CH70(156.525MHz); 灵敏度: ≤6dBμV(e.m.f.) (在误码率小于1%的情况下)
	带宽: 16KHz; 第一中频: 17.9MHz; 第二中频: 455KHz
	邻频选择: ≥70dB; 寄生信号干扰: ≥70dB
无线电发射机	互调干扰: ≥65dB; 接收模式: G2B
	寄生辐射: ≤2nW, 9KHz to 2GHz
	调制类型: G3E(Voice), G2B(DSC); 频率范围: 156.025Mhz~157.425Mhz
	输出功率: 25W,1W (50 Ohms) ; 音频谐波失真: ≤10%
	音频频率响应: +1/-3dB of +6dB/octave, Pre-emphasis 300 - 3000Hz
剩余调制: ≤-40dB; 频偏: 5KHz 最大峰值	
寄生辐射: ≤0.25μW; 电流: ≤5Amps(max)	

安装说明

■ 电气安装

设备使用前,一定要正确的连接电源,天线以及需要连接的外部设备。
设备需要连接电压为12V,输出电流不小于5A的DC电源。

◇ 系统连接图说明

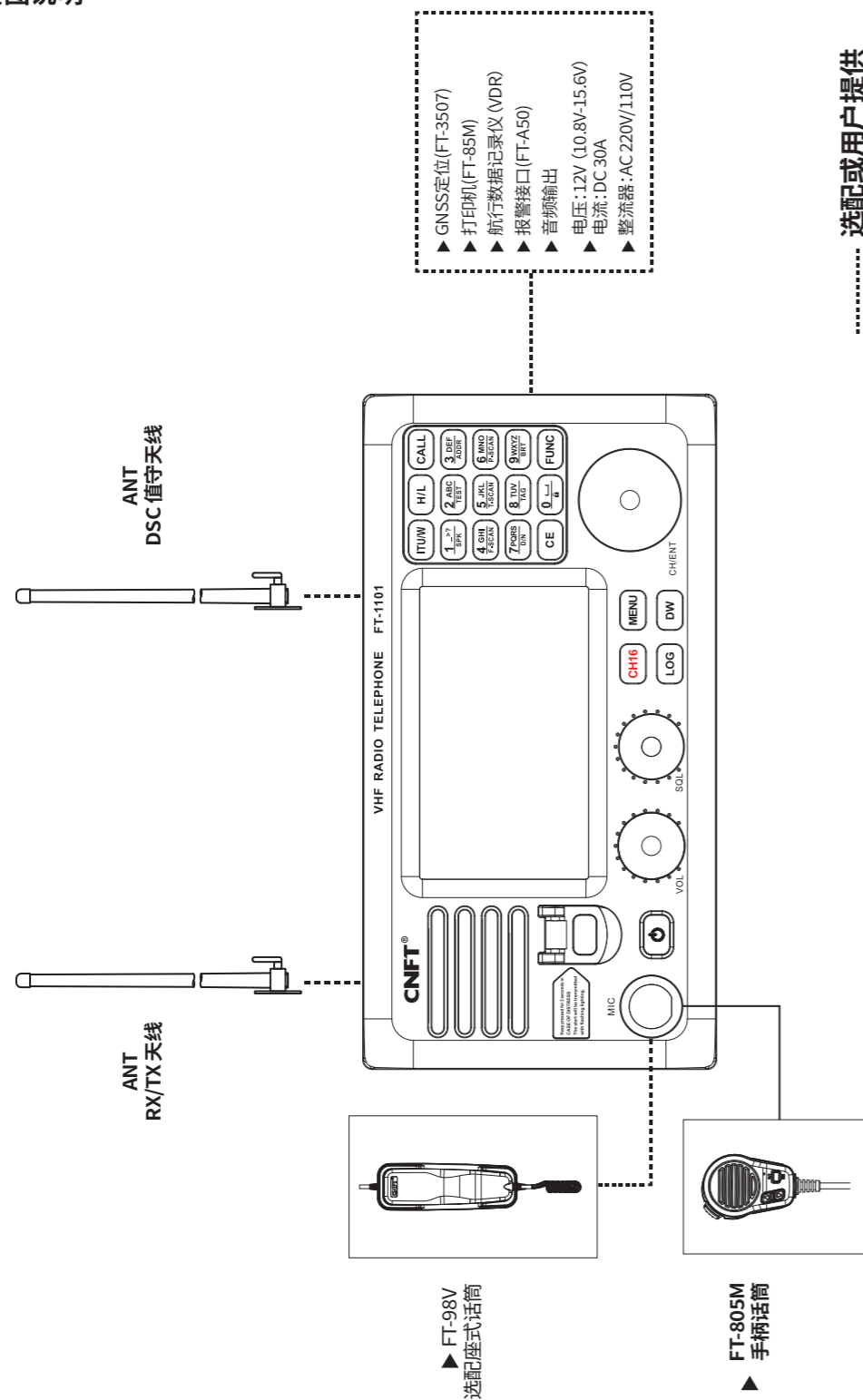

■ 固定安装

- ※ 产品应该安装在远离发动机并通风良好的地方。
- ※ 不要安装在阳光直射的地方。
- ※ 不要把产品放在距离罗经1米之内。

产品配有一个可以翻转的安装支架。支架用5枚螺丝固定。在安装之前,保证在支架后面有100mm的垂直空隙和70mm的水平空隙,以便对产品进行调整。产品的倾斜角度可以通过夹钳进行调整。

显示支架类型

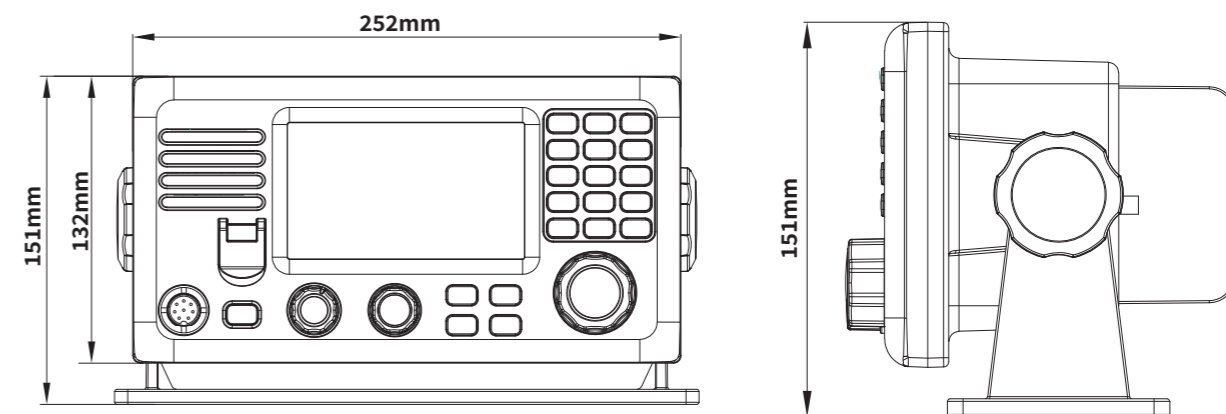

显示支架吊顶类型

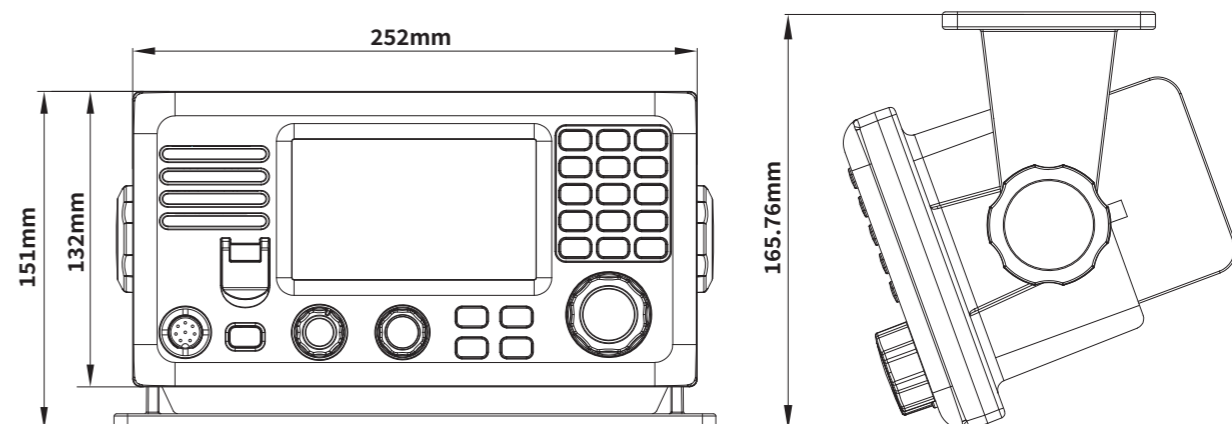

显示嵌入式类型

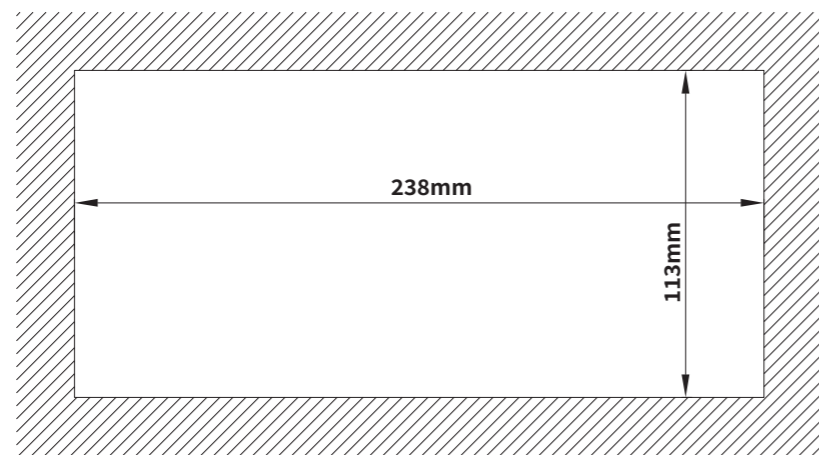
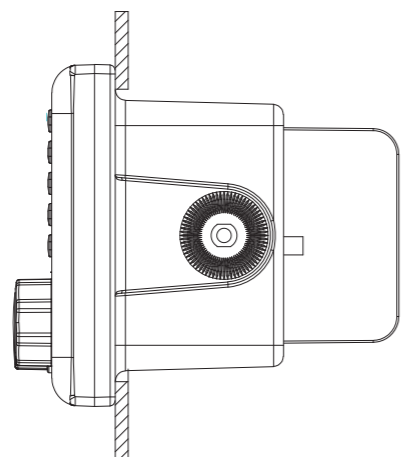
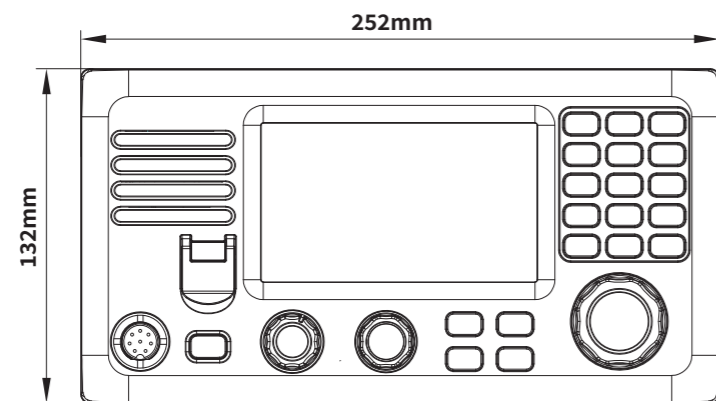

显示单元前视图说明

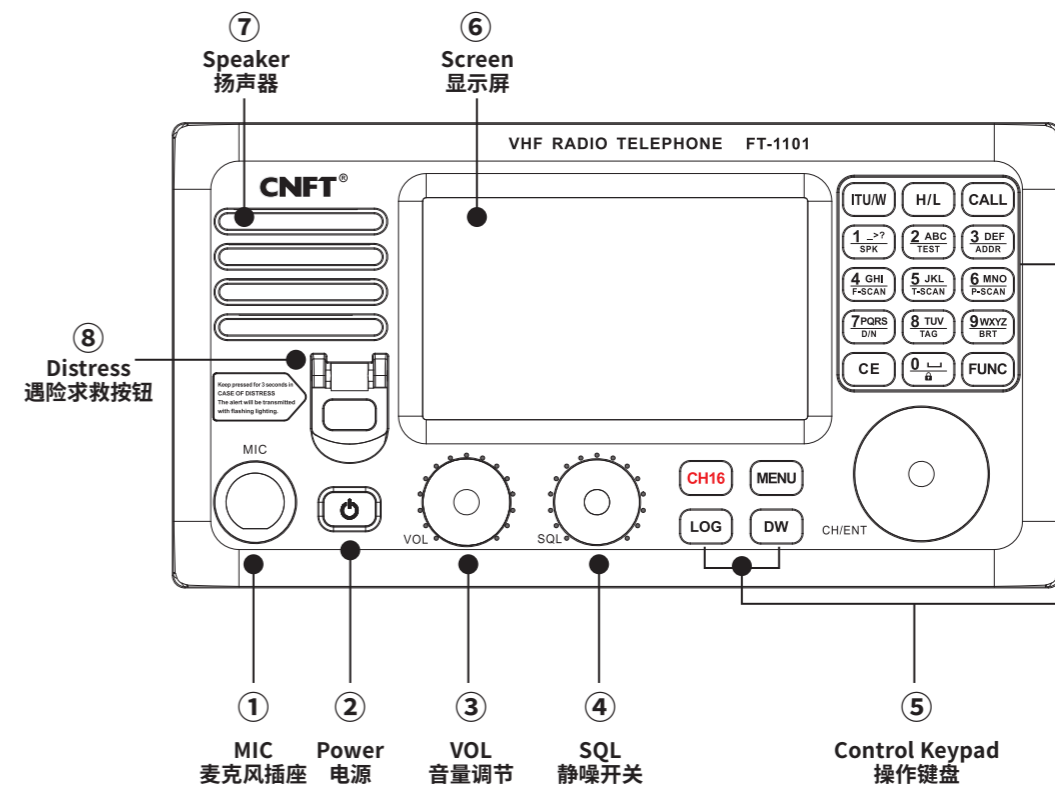

显示单元后视图说明

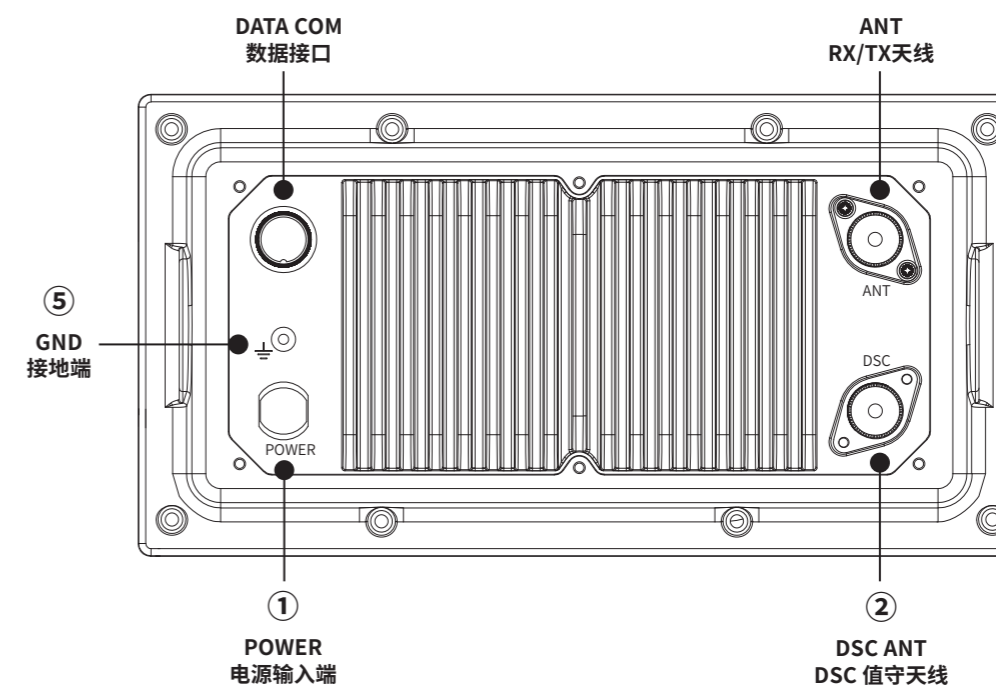

装配图

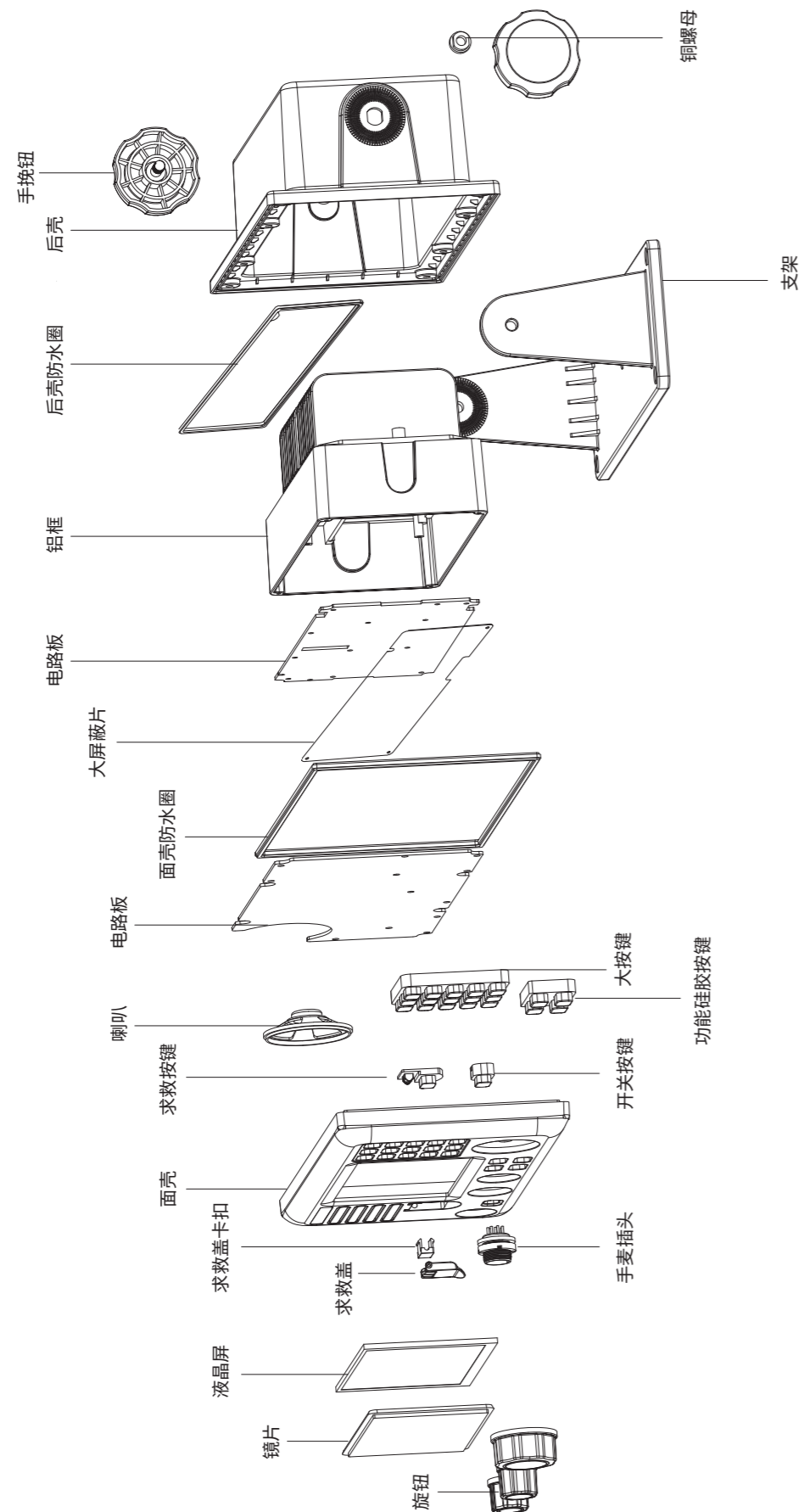

■ 天线安装

天线安装示意图

天线安装十分重要,合理的架设可减少干扰,使通讯距离达到最佳,安装时请注意如下几点:

- ① 天线应架设在垂直位置上,在水平面上应尽可能远离导电物体,最小距离不低于0.5米,天线不能靠近大型的垂直物体,并保证 360°无阻挡。
- ② 天线应尽量远离大功率发射源,如雷达、电台或其他无线电天线,最好离开 3 米以上。
- ③ 两副天线不能在同一平面内,如在同一平面内两副天线间距应在10米以上,条件不允许可将两副天线安装成上下垂直,且高度差应超过 2.5 米以上。
- ④ 室外电缆接口要防水处理。
- ⑤ 天线电缆长度应尽量短,并要远离电源电缆,如果与电缆交叉应保持 90°垂直。
- ⑥ 如安装在灯杆上应用绝缘物体隔离,并在高度上超过1.5米以上。

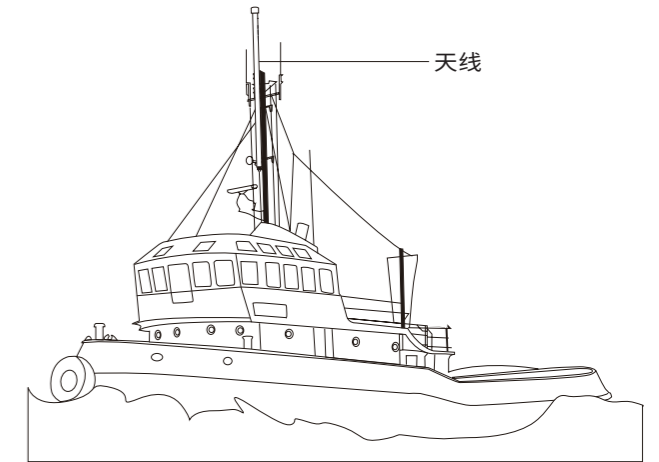

鞭状天线安装示意图

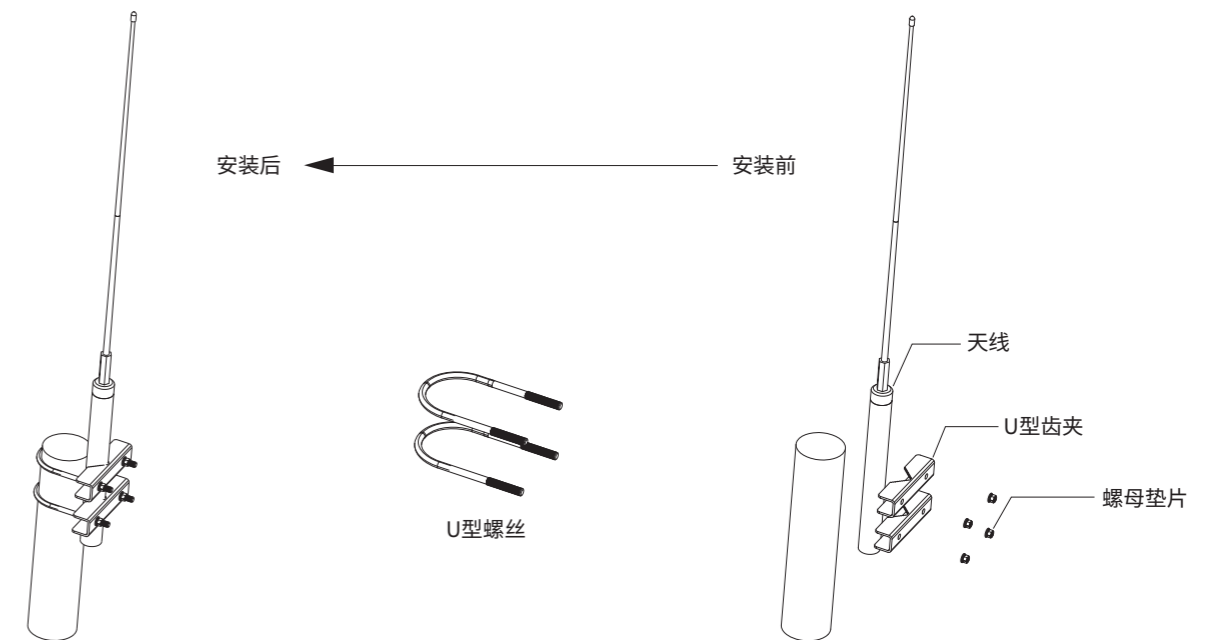

面板说明

FT-1101甚高频无线电装置(A级DSC)是配备DSC单元的多功能电台，有频段转换、扫描、看守、私有频道等功能。本机设计选择铝合金框架为主体，结合高品质的部件，增加防水措施，采用成熟合理的软、硬件技术，使用大屏幕液晶显示及简易的按键操作，使得设备更容易使用。

◇ 前面板布局图

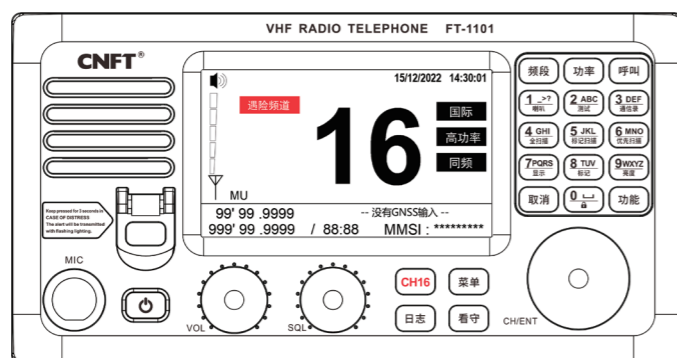

◇ 键盘操作说明

功能	数字键复用功能开启，当按下时显示器显示“FUNC”标识，再按某数字键即开启该数字键的复用功能。
1->? 喇叭	默认功能<数字1>，复用功能<喇叭>; 复用功能： 开启/关闭内置扬声器输出
2 ABC 测试	默认功能<数字2>，复用功能<测试>; 复用功能： 打开DSC测试呼叫编辑界面，可发送/保存该呼叫
3 DEF 通信录	默认功能<数字3>，复用功能<通信录>; 复用功能： 打开通讯录列表
4 GHI 全扫描	默认功能<数字4>，复用功能<全扫描>; 复用功能： 开启全频道扫描功能
5 JKL 标记扫描	默认功能<数字5>，复用功能<标记扫描>; 复用功能： 开启标记/记忆频道扫描功能
6 MNO 优先扫描	默认功能<数字6>，复用功能<优先扫描>; 复用功能： 开启优先频道扫描功能
7 POR 显示	默认功能<数字7>，复用功能<显示>，复用功能： 切换主界面的主题模式； DAY代表白天模式，背景为白色，字体为黑色。NIGHT代表黑夜模式，背景为黑色，字体为白色
8 TUV 标记	默认功能<数字8>，复用功能<标记>; 复用功能： 标记/记忆当前频道
9 WXYZ 背光	默认功能<数字9>，复用功能<背光>; 复用功能： 打开背景灯亮度调节对话框
0 LOCK	默认功能<数字0>，复用功能<LOCK>，复用功能： 锁定按键/旋钮操作 该功能开启后，显示器上会显示“LOCK”标识图标。此时操作按键和旋钮均无响应 可再按此键接触锁定，“LOCK”标识图标消失。

DISTRESS	打开红色保护盖，然后长按此按钮5秒，设备将发送遇险求救呼叫
MIC	麦克风插座
电源开关	电源开关：正确接通电源后，长按3秒钟开机或者关机
VOL	音量控制：调整音量输出水平，右旋增大音量，左旋减小音量
SQL	静噪控制：调整接收机静噪水平，右旋加深静噪，左旋减浅静噪
日志	打开数字选择呼叫日志
看守	开启双看守功能
CH16	快速切换到CH16频道
菜单	打开系统主菜单
CHANNEL	频道旋钮：在主界面下选择工作的频道；在菜单下选择光标的位置。按下时，是【ENT】功能键
频段	选择频段，按下时电台将在国际频段(INT)、美国频段(USA)、加拿大频段(CAN)、天气频段(WX)四种频段内循环选择。 若选择国际频段、美国频段或加拿大频段，电台将自动转到CH16频道。若选择天气频段，电台将自动转到CH01频道
功率	切换功率，高功率(HIGH)->25W，低功率(LOW)->1W。
呼叫	打开呼叫列表菜单，编辑要发送/保存的呼叫。
取消	取消当前操作，返回上一级菜单
LCD	5寸TFT显示器

◇ 显示界面



◇ 显示界面操作说明

序号	说明
1	内部扬声器状态，默认开启状态
2	接收信号强度/发射输出功率指示
3	本机的GNSS信息
4	本机的9位MMSI号码
5	本机的GNSS信息输入状态
6	当前频道属性信 同频 → RX_freq = TX_freq 异频 → RX_freq != TX_freq
7	当前频道设定输出功率状态 高功率 → 25W 低功率 → 1W 禁发射 → 该频道禁止发射
8	当前频段信息 国际 → 国际频段 美国 → 美国频段 加拿大 → 加拿大频段 天气 → 天气频段
9	本地日期和时间

基本操作

◆ 如何开机

正确接通电源后，长按3秒钟开机或者关机。

◆ 如何转换频道

旋转【CHANNEL】频道旋钮转换频道，或者直接按【数字】键输入目标频道然后按【确认】键确认。

◆ 如何进行无线电发射和接收

接收：设备开机后即进入待机状态，屏幕显示“MU”，若在当前频道上接收到信号，那么屏幕使用绿色显示“RX”和“BUSY”，信号强度指示会根据信号的强度产生变化，5格为最强，0格为最弱。

发射：当按下话筒上的【PTT】键时，设备进入无线电发射状态，屏幕使用红色显示“TX”和“BUSY”，功率输出指示会根据发射的功率的大小产生变化，5格为高功率，1格为低功率。

◆ 如何进行双看守

双看守功能：在当前频道和CH16频道之间交替扫描。

按面板上的【看守】键，设备将进行双看守扫描，屏幕显示“SCAN”。

当在看守频道上检测到信号时，设备将继续扫描，不停留在看守频道上。

当在CH16频道上检测到信号时，设备将停留在CH16频道上继续监听该信号直至消失，信号消失30秒后设备将继续扫描。设备停留期间，允许操作者按【PTT】键与对方讲话，设备将退出双看守。按【取消】键取消看守扫描。

◆ 如何进行全频道扫描

全扫描功能：扫描当前频段的所有频道。

首先按面板上的【功能】键，再按【4/全扫描】键，设备将在当前频段内扫描所有频道，包括私有频道（私有频道必须被设置），显示器显示“SCAN”标识。按【取消】键取消全频道扫描。

扫描顺序可通过右旋/左旋频道旋钮或者按咪上的【▲】/【▼】键设置为向上/向下扫描。

当设备在某一频道上检测到信号时，将停留在该频道上监听该信号直至消失，信号消失30秒后设备将继续扫描。

设备停留期间，允许操作者按【PTT】键与对方讲话，设备将退出扫描。

◆ 如何标记/记忆当前频道

首先按面板上的【功能】键，再按【8/标记】键或者直接按【确认】键标记/记忆当前频道。

◆ 如何进行标记/记忆频道扫描

标记扫描功能：扫描当前频段内被标记的频道，首先按面板上的【功能】键，再按【5/标记扫描】键，设备将在当前频段内扫描被标记/记忆的频道，包括私有频道（私有频道必须被设置），屏幕显示“SCAN”。

扫描顺序可通过右旋/左旋频道旋钮或者按手咪上的【▲】/【▼】键设置为向上/向下扫描。

当设备在某一频道上检测到信号时，将停留在该频道上监听该信号直至消失，信号消失30秒后设备将继续扫描。设备停留期间，允许操作者按【PTT】键与对方讲话，设备将退出扫描。

按【取消】键取消标记/记忆频道扫描。

◆ 如何进行优先频道扫描

优先频道扫描功能：在当前频段内被标记的频道和CH16频道之间交替扫描，首先按面板上的【确认】键，再按【6/优先扫描】键，开启优先频道扫描功能，屏幕显示“SCAN”。

扫描顺序可通过右旋/左旋频道旋钮或者按手咪上的【▲】/【▼】键设置为向上/向下扫描。

当在标记频道上检测到信号时，设备将继续扫描，不停留在看守频道上。

当设备在CH16频道上检测到信号时，将停留在CH16频道上监听该信号直至消失，信号消失30秒后设备将继续扫描。设备停留期间，允许操作者按【PTT】键与对方讲话，设备将退出扫描。

按【取消】键取消优先频道扫描。

◆ 如何切换显示模式

在主界面下，先按【功能】键，再按【7/显示】键，主界面的显示模式在日间模式和夜晚模式之间切换。

按【取消】键取消优先频道扫描。

◆ 如何调节屏幕背光亮度

屏幕的背光亮度等级分为10级。首先按面板上的【功能】键，再按【9/背光】键打开背光亮度对话框，通过右旋/左旋频道旋钮或者按手咪上的【▲】/【▼】键进行设置。

按【取消】键退出对话框。

遇险报警呼叫操作

※ DSC的操作须在设备有正确的MMSI号码后才可以进行，如果没有有效的MMSI号码，那么按面板上的【DIST】键和【呼叫】键时，会弹出没有MMSI号码警告提示框。以下操作默认为设备已经设置了有效的MMSI号码以及正确连接了GNSS设备。

◆ 遇险报警呼叫

◇ 发送遇险报警呼叫

a:首先按面板上的【DIST】键，打开发送遇险报警呼叫操作界面，如图4.1.1所示。

遇险报警	
呼叫目标：	所有台
遇险船：	123456789
遇险种类：	未指明种类
遇险位置：	99°99.9999 -. / 88:88 Utc
通信频率：	CH-0016 / 无线电话
发送频率：	CH-0070
长按<遇险>键5秒钟发送遇险报警!	

图4.1.1

b:按【确认】键打开遇险种类列表，使用频道旋钮选择遇险的种类。遇险的种类包括：火灾、进水、碰撞、搁浅、倾斜、沉没、失去控制、未指明种类、弃船、海盗、有人落水、错误种类共12种。默认为未指明种类。

c:设备允许操作者手动输入GNSS信息，旋转频道旋钮将光标转到<遇险位置>项，按【数字】键打开GNSS信息输入对话框，输入正确的GNSS信息。然后按【确认】键确认。

d:长按【DIST】键5秒钟，5秒钟后发送遇险报警呼叫设备发送完遇险报警呼叫后进入等待应答呼叫模式。在该模式下设备已经跳转到16频道上准备通话，并且在20~50秒范围内的随机时间重复发出报警声音，如果3.5~4.5分钟内没有接收到应答呼叫，那么设备自动再次发送遇险报警呼叫。

选择<停止>项，设备将停止自动重发，选择<重发>项，设备将立即重发遇险报警呼叫。

若设备被误发射了遇险报警呼叫，那么要按照如下操作及时的取消该报警：

- a)在等待应答呼叫模式下选择<取消>项，或者按【取消】键，发送报警取消呼叫取消该报警。
 - b)使用无线电在16频道上报告自己的信息。
- 例如：“所有船舶。。。所有船舶。。。所有船舶。。。这里是（本船的名称和本台的呼号），MMSI是XXXXXX
XX，我的位置是XX度XX分，XXX度XX分，在XXXX年XX月XX日XX点XX分取消我的未指明类型遇险报警！”
- c)继续其他操作。

◇ 接收遇险报警应答呼叫

当设备接收到遇险报警应答呼叫时，会发出报警声音，显示报警应答呼叫包含的信息，如图4.1.2所示，同时设备已经跳转到16频道等待通话。



图4.1.2

◇ 接收遇险报警呼叫

当设备接收到遇险报警呼叫时，会发出报警声音，显示报警呼叫包含的信息，如图4.1.3所示，同时设备已经自动转到16频道等待通话。



图4.1.3

若要转发该条报警，那么选择<转发>项，按【确认】键，打开转发类型菜单，选择转发到单台或所有台，然后再按【确认】键发送呼叫。

若要发送遇险报警应答呼叫，那么选择<应答>项，按【确认】键发送应答呼叫。

按【取消】键或者选择<关闭>项返回到主界面操作。

◆ 遇险报警转发呼叫

◇ 将遇险报警转发到所有台

- a:按面板上的【呼叫】键，打开呼叫类型列表。
- b: 使用频道旋钮选择<转发遇险报警到所有台>项，按【确认】键打开编辑界面。如图4.2.1所示。



图4.2.1

c: 旋转频道旋钮选择<遇险船>项，使用数字键盘输入遇险船的MMSI号码，也可以按【确认】键，打开通讯录，从通讯录中选择MMSI号码。

d: 旋转频道旋钮选择<遇险种类>项，遇险的种类包括：火灾、进水、碰撞、搁浅、倾斜、沉没、失去控制、未指明种类、弃船、海盗、有人落水共11种，按【确认】键确认。

e: 旋转频道旋钮选择<遇险位置>项，按【数字】键打开GNSS信息输入对话框，输入正确的GNSS信息，然后按【确认】键确认。

f: 旋转频道旋钮选择<发送>项，按【确认】键发送遇险报警转发呼叫。发送完毕后设备自动跳转到16频道上准备通话。

◇ 接收转发到所有台的遇险报警呼叫

参见4.1.3节接收遇险报警呼叫的操作。



图4.2.2

◇ 将遇险报警转发到单台

a: 按面板上的【呼叫】键，打开呼叫类型列表。

b: 使用频道旋钮选择<转发遇险报警到单台>项，按【确认】键打开编辑界面，如图4.2.3所示。



图4.2.3

c: 旋转频道旋钮选择<呼叫目标>项，使用数字键盘输入遇险船的MMSI号码，也可以按【确认】键,打开通讯录，从通讯录中选择MMSI号码。

d: 旋转频道旋钮选择<遇险船>项，使用数字键盘输入遇险船的MMSI号码，也可以按【确认】键，打开通讯录，从通讯录中选择MMSI号码。

e: 旋转频道旋钮选择<遇险种类>项，遇险的种类包括：火灾、进水、碰撞、搁浅、倾斜、沉没、失去控制、未指明种类、弃船、海盗、有人落水共11种，按【确认】键确认。

f: 旋转频道旋钮选择<遇险位置>项，按【数字】键打开GNSS信息输入对话框，输入正确的GNSS信息。然后按【确认】键确认。

g: 旋转频道旋钮选择<发送>项，按【确认】键发送遇险报警转发呼叫。发送完毕后设备转到等待应答界面，并自动跳转到16频道上准备通话

◇ 接收转发到单台的遇险报警应答呼叫

参见4.1.2节接收遇险报警应答呼叫的操作。



图4.2.4

◇ 接收转发到单台的遇险报警呼叫

参见4.1.3节接收遇险报警呼叫的操作。



图4.2.5

普通呼叫操作

※DSC的操作须在设备有正确的MMSI号码后才可以进行，如果没有有效的MMSI号码，那么面板上的【DIST】键和【呼叫】键时，会弹出没有MMSI号码警告提示框。

以下操作默认为设备已经设置了有效的MMSI号码以及正确连接了GNSS设备。

◆ 单台呼叫

◇ 发送单台呼叫

a: 面板上的【呼叫】键，打开呼叫类型列表。

b: 使用频道旋钮选择<单台呼叫>项，按【确认】键打开编辑界面，如图5.1.1所示。



图5.1.1

c: 旋转频道旋钮选择<呼叫目标>项，使用数字键盘输入目标船的MMSI号码，也可以按【确认】键，打开通讯录，从通讯录中选择MMSI号码。

d: 旋转频道旋钮选择<呼叫种类>项，按【确认】键打开呼叫级别列表，选择后按【确认】键确认。

e: 旋转频道旋钮选择<通信频率>项，使用【数字】键输入频道号码。

f: 旋转频道旋钮选择<发送>项，按【确认】键发送该条呼叫。

g: 发送完呼叫后，设备等待应答呼叫，可以选择<重发>项，按【确认】键再一次发送该条呼叫。

※ 选择<保存>项，将该条呼叫保存到呼叫文件中。

◇ 接收单台应答呼叫

当设备接收到单台应答呼叫时，会发出提示声音。显示应答呼叫包含的信息，如图5.1.2所示，同时设备已经跳转到通信频道上等待通话。



图5.1.2

选择<打印>项，按【确认】键打印该条呼叫。

选择<关闭>项，按【确认】键关闭该界面，返回到主界面操作。

◇ 接收单台呼叫

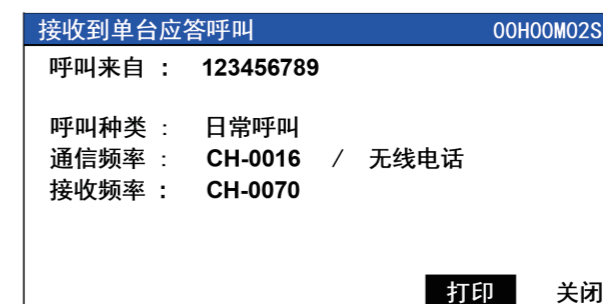
当设备接收到单台呼叫时，会发出提示声音，显示该呼叫包含的信息，如图5.1.3所示。



图5.1.3

如果在数字选呼菜单中的频率转换设置为自动模式，那么设备在收到呼叫的时候将自动转换频道否则在接收到呼叫时，设备的当前频道并未转换到通信频道上，需要用户选择<转换频率>项，按【确认】键转换到通信频道。

如果需要应答,则选择<应答>项,按【确认】键发送应答呼叫,发送完毕后设备自动转到通信频道准备通话。

如果需要半应答,则选择<半应答>项,按【确认】键打开半应答原因对话框,选择相应的原因后,按【确认】键确认,发送半应答呼叫,发送完毕后返回到主界面。

选择<打印>项,按【确认】键打印该条呼叫。

选择<关闭>项,按【确认】键关闭该界面,返回到主界面操作。

◆ 所有台呼叫

◇ 发送所有台呼叫

a:按面板上的【呼叫】键,打开呼叫类型列表。

b:使用频道旋钮选择<所有台呼叫>项,按【确认】键打开编辑界面,如图5.2.1所示。



图5.2.1

c:旋转频道旋钮选择<呼叫种类>项,按【确认】键打开呼叫级别列表,选择后按【确认】键确认。

d:旋转频道旋钮选择<通信频率>项,使用数字键盘输入频道号码。

e:旋转频道旋钮选择<发送>项,按【确认】键发送该条呼叫。

f:发送完呼叫后,设备已经转到通信频道上准备通话,也可以选择<RSEND>项,按【确认】键再一次发送该条呼叫。

※ 选择<保存>项,将该条呼叫保存到呼叫文件中。

◇ 接收所有台呼叫

当设备接收到所有台呼叫时,会发出提示声音,显示该呼叫包含的信息,如图5.2.2所示。



图5.2.2

如果在数字选呼菜单中的频率转换设置为自动模式,那么设备在收到呼叫的时候将自动转换频道,否则在接收到呼叫时,设备的当前频道并未转换到通信频道上,需要用户选择<转换频率>项,按【确认】键转换到通信频率。

选择<打印>项,按【确认】键打印该条呼叫。

选择<关闭>项,按【确认】键关闭该界面,返回到主界面操作。

◆ 群组呼叫

◇ 发送群组呼叫

a:按面板上的【呼叫】键,打开呼叫类型列表。

b:使用频道旋钮选择<群组呼叫>项,按【确认】键打开编辑界面,如图5.3.1所示。

c:旋转频道旋钮选择<呼叫目标>项,使用数字键盘输入群组的ID号码,也可以按【确认】键,打开通讯录,从通讯录中选择群组ID号码。

d:旋转频道旋钮选择<呼叫种类>项,按【确认】键打开呼叫级别列表,选择后按【确认】键确认。

e:旋转频道旋钮选择<通信频率>项,使用数字键盘输入频道号码。



图5.3.1

f: 旋转频道旋钮选择<发送>项, 按【确认】键发送该条呼叫。

g: 发送完呼叫后, 设备已经转到通信频道上准备通话, 也可以选择<重发>项, 按【确认】键再一次发送该条呼叫。

※ 群组呼叫的呼叫级别仅可以选择日常呼叫。

※ 选择<保存>项, 将该条呼叫保存到呼叫文件中。

◇ 接收群组呼叫

当设备接收到群组呼叫时, 会发出提示声音, 显示该呼叫包含的信息, 如图5.3.2所示。



图5.3.2

如果在数字选呼菜单中的频率转换设置为自动模式, 那么设备在收到呼叫的时候将自动转换频道, 否则在接收到呼叫时, 设备的当前频道并未转换到通信频道上, 需要用户选择<转换频率>项。

按【确认】键转换到通信频率。

选择<打印>项, 按【确认】键打印该条呼叫。

选择<关闭>项, 按【确认】键关闭该界面, 返回到主界面操作。

◆ 电话呼叫

◇ 发送电话呼叫

a: 按面板上的【呼叫】键, 打开呼叫类型列表。

b: 使用频道旋钮选择<电话呼叫>项, 按【确认】键打开编辑界面, 如图5.4.1所示。



图5.4.1

c: 旋转频道旋钮选择<呼叫目标>项, 使用数字键盘输入目标的MMSI号码, 也可以按【确认】键, 打开通讯录, 从通讯录中选择MMSI号码。

d: 旋转频道旋钮选择<电话号码>项, 使用数字键盘输入要接通的电话号码, 也可以按【确认】键打开通讯录, 从通讯录中选择电话号码。

e: 旋转频道旋钮选择<发送项>, 按【确认】键发送该条呼叫。

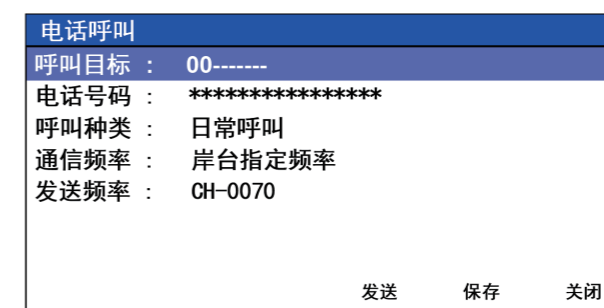
f: 发送完呼叫后, 设备等待应答呼叫, 可以选择<重发项>, 按【确认】键再一次发送该条呼叫。

※ 选择<保存>项, 将该条呼叫保存到呼叫文件中。

◇ 接收电话应答呼叫

当设备接收到电话应答呼叫时, 会发出提示声音。显示应答呼叫包含的信息, 如图5.4.2所示, 同时设备已经跳转到通话频道上等待通话。



图5.4.2

选择<打印>项,按【确认】键打印该条呼叫。

选择<关闭>项,按【确认】键关闭该界面,返回到主界面操作。

◇ 接收电话呼叫

当设备接收到电话呼叫时,会发出提示声音,显示该呼叫包含的信息,如图5.4.3所示。



图5.4.3

如果在数字选呼菜单中的频率转换设置为自动,那么设备在收到呼叫的时候将自动转换频道,否则在接收到呼叫时,设备的当前频道并未转换到通信频道上,需要用户选择<转换频率>项,按【确认】键转换到通信频道。

如果需要应答,则选择<应答>项,按【确认】键发送应答呼叫,发送完毕后设备自动转到到通信频道准备通话。

如果需要半应答,则选择<半应答>项,按【确认】键打开半应答原因对话框,选择相应的原因后,按【确认】键确认,发送半应答呼叫,发送完毕后返回到主界面。

选择<打印>项,按【确认】键打印该条呼叫。

选择<关闭>项,按【确认】键关闭该界面,返回到主界面操作。

◆ 位置请求呼叫

◇ 发送位置请求呼叫

a:按面板上的【呼叫】键,打开呼叫类型列表。

b:使用频道旋钮选择<位置请求呼叫>项,按【确认】键打开编辑界面,如图5.5.1所示。



图5.5.1

c:旋转频道旋钮选择<呼叫目标>项,使用数字键盘输入目标船的MMSI号码,也可以按【确认】键,打开通讯录,从通讯录中选择MMSI号码。

d:旋转频道旋钮选择<发送>项,按【确认】键发送该条呼叫。

e:发送完呼叫后,设备等待应答呼叫,可以选择<重发>项,按【确认】键再一次发送该条呼叫。

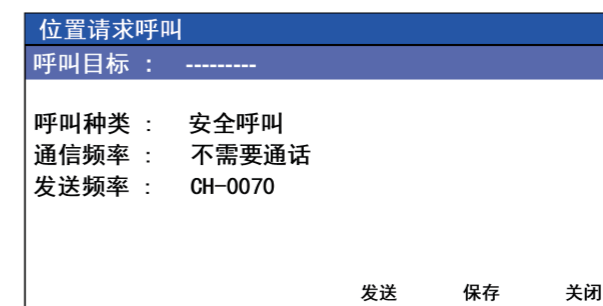
※选择<保存>项,将该条呼叫保存到呼叫文件中。

◇ 接收位置请求应答呼叫

当设备接收到位置请求应答呼叫时,会发出提示声音,显示应答呼叫包含的信息,如图5.5.2所示。



图5.5.2

选择<打印>项,按【确认】键打印该条呼叫。

选择<关闭>项,按【确认】键关闭该界面,返回到主界面操作。

◇ 接收位置请求呼叫

当设备接收到位置请求呼叫时，会发出提示声音，显示该呼叫包含的信息,如图5.5.3所示。



图5.5.3

- 选择<应答>项，按【确认】键发送应答呼叫。
- 选择<打印>项，按【确认】键打印该条呼叫。
- 选择<关闭>项，按【确认】键关闭该界面，返回到主界面操作。

◆ 测试呼叫

◇ 发送测试呼叫

- a:按面板上的【呼叫】键，打开呼叫类型列表。
- b:使用频道旋钮选择<测试呼叫>项，按【确认】键打开编辑界面,如图5.6.1所示。
- c: 旋转频道旋钮选择<呼叫目标>项，使用数字键盘输入目标船的MMSI号码，也可以按【确认】键，打开通讯录，从通讯录中选择MMSI号码。
- d:旋转频道旋钮选择<发送>项，按【确认】键发送该条呼叫。
- e:发送完呼叫后，设备等待应答呼叫，可以选择<重发>项，按【确认】键再一次发送该条呼叫。
- ※选择<保存>项，将该条呼叫保存到呼叫文件中。



图5.6.1

◇ 接收测试应答呼叫

当设备接收到测试应答呼叫时，会发出提示声音，显示应答呼叫包含的信息，如图5.6.2所示。



图5.6.2

- 选择<打印>项，按【确认】键打印该条呼叫。
- 选择<关闭>项，按【确认】键关闭该界面，返回到主界面操作。

◇ 接收测试呼叫

当设备接收到测试呼叫时，会发出提示声音，显示该呼叫包含的信息,如图5.6.3所示。

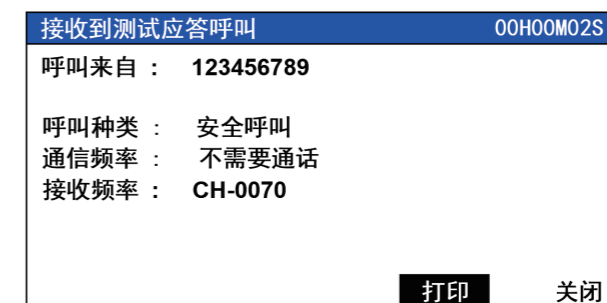

图5.6.3

- 选择<应答>项，按【确认】键发送应答呼叫。
- 选择<打印>项，按【确认】键打印该条呼叫。
- 选择<关闭>项，按【确认】键关闭该界面，返回到主界面操作。

◆ 数据呼叫

参见本手册第5.1节有关单台呼叫的操作。呼叫列表中选择<数据呼叫>项。

◆ 中立船呼叫

※只有在设备的特殊呼叫被使能情况下才可以发送中立船呼叫。

使能特殊呼叫操作详见菜单操作。

参见本手册第5.2节有关所有台呼叫的操作。呼叫列表中选择<中立船呼叫>项。

中立船呼叫的呼叫级别仅为紧急呼叫。

◆ 医疗船呼叫

※只有在设备的特殊呼叫被使能情况下才可以发送医疗船呼叫。

使能特殊呼叫操作详见菜单操作。

参见本手册第5.2节有关所有台呼叫的操作。呼叫列表中选择<医疗船呼叫>项

医疗船呼叫的呼叫级别仅为紧急呼叫。

◆ 查询呼叫

※设备仅接收查询呼叫

当设备接收到查询呼叫时，会发出提示声音，显示该呼叫包含的信息，如图5.10.1所示。



图5.10.1

选择<应答>项，按【确认】键发送应答呼叫。

选择<打印>项，按【确认】键打印该条呼叫。

选择<关闭>项，按【确认】键关闭该界面，返回到主界面操作。

菜单操作

◆ 如何使用菜单

按面板上的【菜单】键打开主菜单，旋转【CHANNEL】频道旋钮选择要进入的子菜单或操作项，再按【确认】键确认并进入子菜单。按【CE】键返回上一级菜单。



图6.1

◆ 编辑用户频道

设备可以使用100个用户频道，使用之前必须先设置用户频道的发送和接收频率。

如何编辑用户频道：

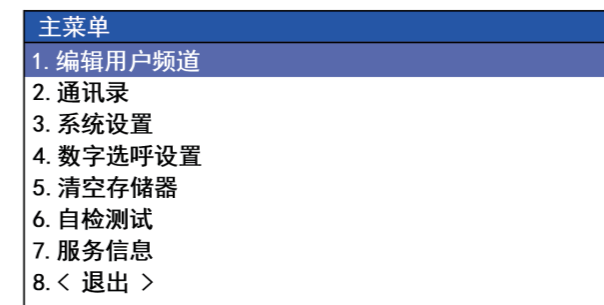
a:在主菜单中，选择<编辑用户频道>项，按【确认】键打开频道信息列表。

b:选择需要编辑的频道号码，然后按【确认】键打开频道操作对话框，如图6.2.1所示，选择<编辑选中的频道>，按【确认】键打开编辑对话框。



图6.2.1



图6.2.2

c:使用【数字】键输入发射频率和接收频率，然后旋转【CHANNEL】频道旋钮选择<保存>项，按【ENT】键保存。

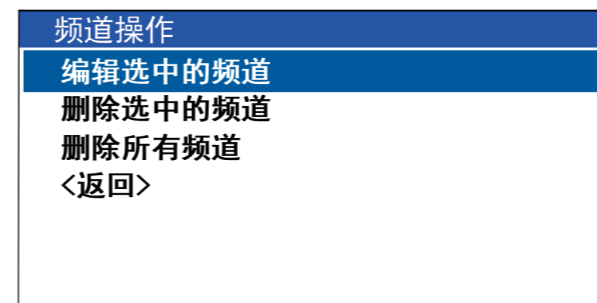
如何删除用户频道：

在本节b步骤打开的频道操作对话框中，旋转【CHANNEL】频道旋钮选择<删除选中频道>项或者<删除所有频道>项，然后按【ENT】键后设备将删除对应的频道。

※用户频道的发射/接收频率必须要在海事频率的范围内，并且要能被25KHz整除。

◆ 通讯录

设备允许操作者存储20条船舶、20条岸台，20条群组的MMSI号码和20条电话号码，方便在发送呼叫时输入。

如何增加/编辑一个条目：

a:在主菜单中选择<通讯录>项，按【ENT】键打开通讯录列表。

b:旋转【CHANNEL】频道旋钮选择要编辑的条目，按【ENT】键打开条目操作对话框,如图6.3.1所示；



图6.3.1



图6.3.2

c:旋转【CHANNEL】频道旋钮选择<编辑选中的条目>项，按【ENT】键打开编辑条目信息对话框，使用数字键盘输入条目的名称和号码。

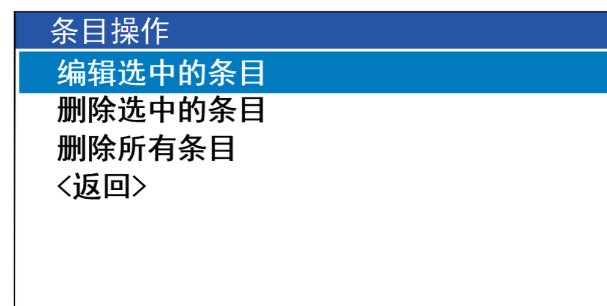
d:信息输入完毕后，旋转【CHANNEL】频道旋钮到<保存>项，按【ENT】键确认保存。

如何删除条目：

在本节b步骤打开的条目操作对话框中，旋转【CHANNEL】频道旋钮选择<删除选中的条目>项或者<删除所有的条目>项，按【ENT】键后设备将删除对应的条目。

◆ 系统设置

在主菜单中选择<系统设置>项，按【ENT】键打开系统设置菜单。



图6.4

系统设置菜单中包括：

- 1.本地时间设置[RTC TIME SETUP]
- 2.时区设置[TIME ZONE]
- 3.最大发射时间设置[TX TIMEOUT]
- 4.显示模式设置[DISP MODE]
- 5.语言设置[LANGUAGE]
- 6.按键声音[KEY TONE]
- 7.GNSS串口速率[GNSS RATE]
- 8.数据串口速率（串口打印机接口）[DATE RATE]

旋转【CHANNEL】频道旋钮选择要设置的项，按【ENT】键打开该项对应的设置列表单，在设置列表单中旋转【CHANNEL】频道旋钮选择要设置的值，最后按【ENT】键确认。

◇ 本地时间设置

设备内部有RTC时间模块，可以产生本地日期和时间。

如何设置内部RTC：

a:在系统设置菜单中选择<本地时间设置>项，按【ENT】键打开本地时间设置对话框，如图6.4.1所示。



图6.4.1

b:使用数字键输入日期与时间信息，也可旋转【CHANNEL】频道旋钮控制光标的位置，更改该位置上的数字。输入完毕后按选择<保存>项，按【ENT】键保存时间信息。

◆ 数字选呼设置

◇ 本机MMSI设置

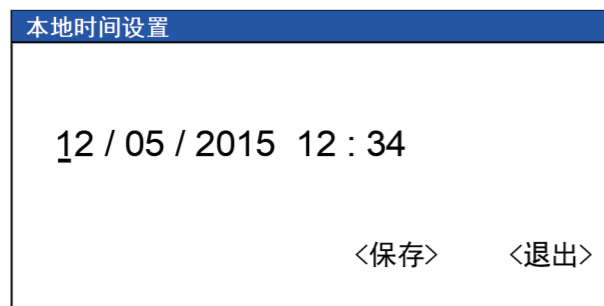
设备可以允许用户更改3次本机MMSI号码，超过3次后要输入更改密码才可以继续更改MMSI号码。

- a:在数字选呼设置菜单中选择<MMSI 号码设置>项，按【ENT】键打开本机MMSI号码设置对话框，如图6.5.1所示。
- b:使用【数字】键输入MMSI号码信息，旋转【CHANNEL】频道旋钮控制光标的位置，更改该位置上的数字。输入完毕后按选择<保存>项保存时间信息。
- c:按【ENT】键返回到数字选呼设置菜单。



图6.5.1

◇ 查看呼叫日志

设备可以保存预先编辑的普通呼叫，发射和接收的报警呼叫与普通呼叫，每种类型的呼叫可以保存20条。

- a:在数字选呼菜单中选择<查看呼叫日志>项，按【ENT】键或在主界面按【LOG】打开呼叫日志列表。
- b:旋转【CHANNEL】频道旋钮选择要查看的呼叫日志类型，按【ENT】键打开相应的呼叫日志文件列表。
- c:旋转【CHANNEL】频道旋钮选择要操作的呼叫，按【ENT】键打开呼叫日志操作对话框，如图6.5.2所示。

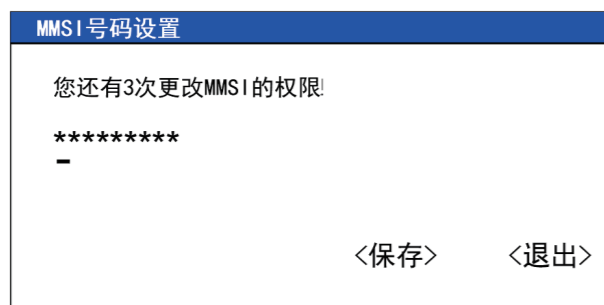

图6.5.2

- d:转频道旋钮选择要进行的操作（查看，删除）。
- e:按【CE】键退出呼叫日志列表。

◇ 位置设置

当设备没有外接GNSS时，设备允许用户手动输入GNSS信息。

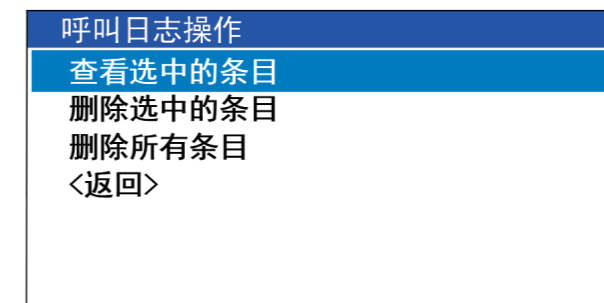
- a:在数字选呼设置菜单中选择<GNSS 信息设置>项，按【ENT】键打开GNSS信息设置对话框,如图6.5.3所示。
- b:使用【数字】键输入GNSS信息，旋转【CHANNEL】频道旋钮控制光标的位置，更改该位置上的数字。输入完毕后按选择<SAVE>项保存时间信息。
- c:按【ENT】键返回到数字选呼设置菜单。



图6.5.3

◇ 应答设置

设备允许用户自行设置呼叫的应答模式，所有呼叫的应答模式默认为手动应答。

- a:在数字选呼设置菜单中选择<应答设置>项，按【ENT】键打开应答设置对话框,如图6.5.4.1所示。
- b:旋转【CHANNEL】频道旋钮选择要设置的呼叫类型，按【ENT】键打开应答模式列表，如图6.5.4.2所示；
- c:旋转【CHANNEL】频道旋钮选择应答模式，按【ENT】键确认。



图6.5.4.1



图6.5.4.2

d:按【CE】键返回到数字选呼设置菜单。

※当应答模式设置为自动应答（UNABLE）模式时，需要设置的UNABLE原因。

◇ 打印设置

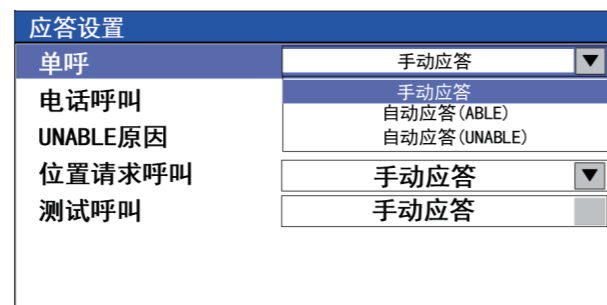
设备支持连接串口打印机(需连接指定型号，具体请咨询供应商)，当发送或者接收到呼叫时打印呼叫信息。设备可以设置打印模式为自动打印或者手动打印两种模式，设备默认是手动打印模式。

- a:在数字选呼设置菜单中选择<打印设置>项，按【ENT】键打开应答设置对话框,如图6.5.5.1所示。
- b:旋转【CHANNEL】频道旋钮选择需要设置的呼叫类型，按【ENT】键打开状态列表，如图6.5.5.2所示。



图6.5.5.1



图6.5.5.2

- c:旋转【CHANNEL】频道旋钮选择要设置的打印模式，按【ENT】键确认。
- d:按【CE】键返回到数字选呼设置菜单。

◇ 频率转换设置

当设备收到普通呼叫时，设备允许用户设置通话频道的转换模式，分为自动转换和手动转换。设备默认是自动转换。

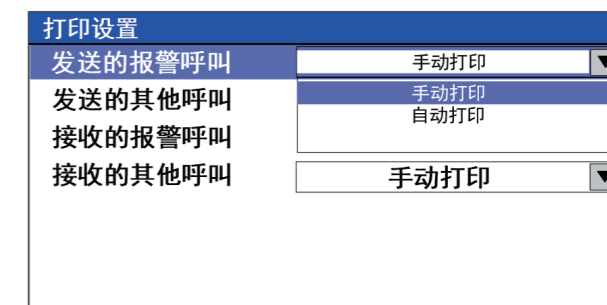
- a:在数字选呼设置菜单中选择<频率转换设置>项，按【ENT】键打开频率转换设置对话框,如图6.5.6.1所示。
- b:旋转【CHANNEL】频道旋钮选择要设置的呼叫级别，按【ENT】键打开转换模式列表，如图6.5.6.2所示。
- c:旋转【CHANNEL】频道旋钮选择转换模式，按【ENT】键确认。
- d:按【CE】键返回到数字选呼设置菜单。



图6.5.6.1



图6.5.6.2

◇ 特殊呼叫设置

特殊呼叫包括中立船呼叫和医疗船呼叫，设备默认特殊呼叫是禁止发送的，用户可在该菜单项中使能特殊呼叫。

- a:在数字选呼设置菜单中选择<特殊呼叫设置>项，按【ENT】键打开特殊呼叫设置对话框，如图6.5.7.1所示。
- b:旋转【CHANNEL】频道旋钮选择要设置的呼叫类型，按【ENT】键打开特殊呼叫状态列表，如图6.5.7.2所示。
- c:旋转【CHANNEL】频道旋钮选择特殊呼叫的使能状态，按【ENT】键确认。
- d:按【CE】键返回到数字选呼设置菜单。



图6.5.7.1



图6.5.7.2

◆ 清空存储器

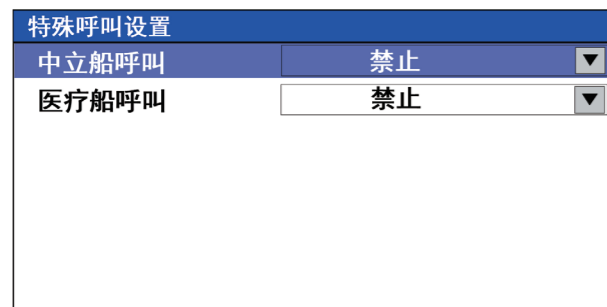
当设备设置有误或者需要清除各类信息时，可以使用此功能。主菜单中<清空存储器>将清除用户所设置的所有信息，包括菜单项设置、用户频道的频率和通讯录信息。

- a:在主菜单中选择<清空存储器>项，按【ENT】键打开恢复出厂设置对话框。
- b:旋转【CHANNEL】频道旋钮选择<确认>项，按【ENT】键将清除存储器上所有的用户信息。
- c:按【CE】键返回主菜单。

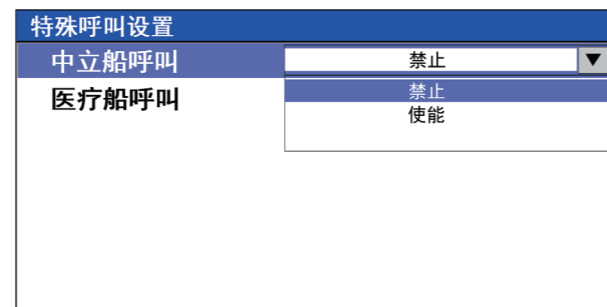
◆ 自检测试

设备具有自检功能，检测设备的接收，发射，DSC和存储器的工作状态是否正确。

- a:在主菜单中选择<自检测试>项，按【ENT】键打开自检测试对话框，设备开始进行自检。
- b:待自检完成后，按【ENT】键或者【CE】键返回主菜单。

◆ 服务信息

显示设备的机器编号，当前的硬件版本信息和软件版本信息，出厂日期。

- a:在主菜单中选择<服务信息>项，按【ENT】键打开服务信息对话框。
- b:按【CE】键返回主菜单。

GNSS设备连接

FT-1101的GNSS接口可连接带有RS232或者RS422输出的GNSS接收机，通信速率可选，详见菜单操作，FT-1101接收的GNSS数据格式为NMEA0183 version 2.0中的RMC,GGA,GLL,ZDA,GNS语句。

当设备正确连接到了GNSS设备并且接收到有效的GNSS信息时，屏幕显示“-- AUTO INPUT --”，如果设备与GNSS设备连接中断30秒后，那么设备将保存最后接收的GPS信息，屏幕显示“-- Lost - 30s --”。

设备的GNSS信息如果在4小时内没有得到更新，那么设备屏幕显示“-- Lost - 4hour --”，并且会发出警告提示框，如图7.1所示，按【CE】键关闭警告提示框。

设备的GNSS信息如果在23.5小时内没有得到更新，那么设备屏幕显示“--Lost - 23.5hour --”，并且会发出警告提示框，如图7.2所示，同时将设备的GNSS信息设置为默认的无效信息，按【CE】键关闭警告提示框。

※GNSS的无效信息为经纬度的数字全为9，UTC时间的数字全为8。



图7.1



图7.2

系统接口规格说明

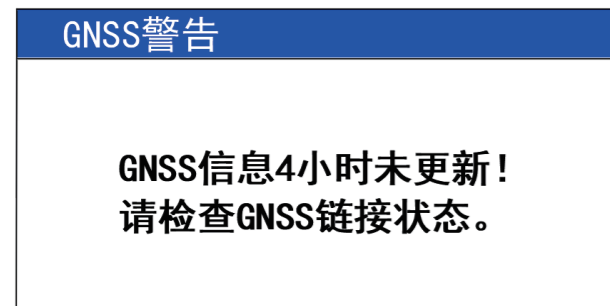
显示单元前视图说明

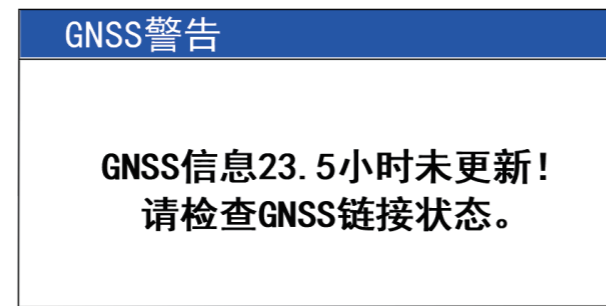
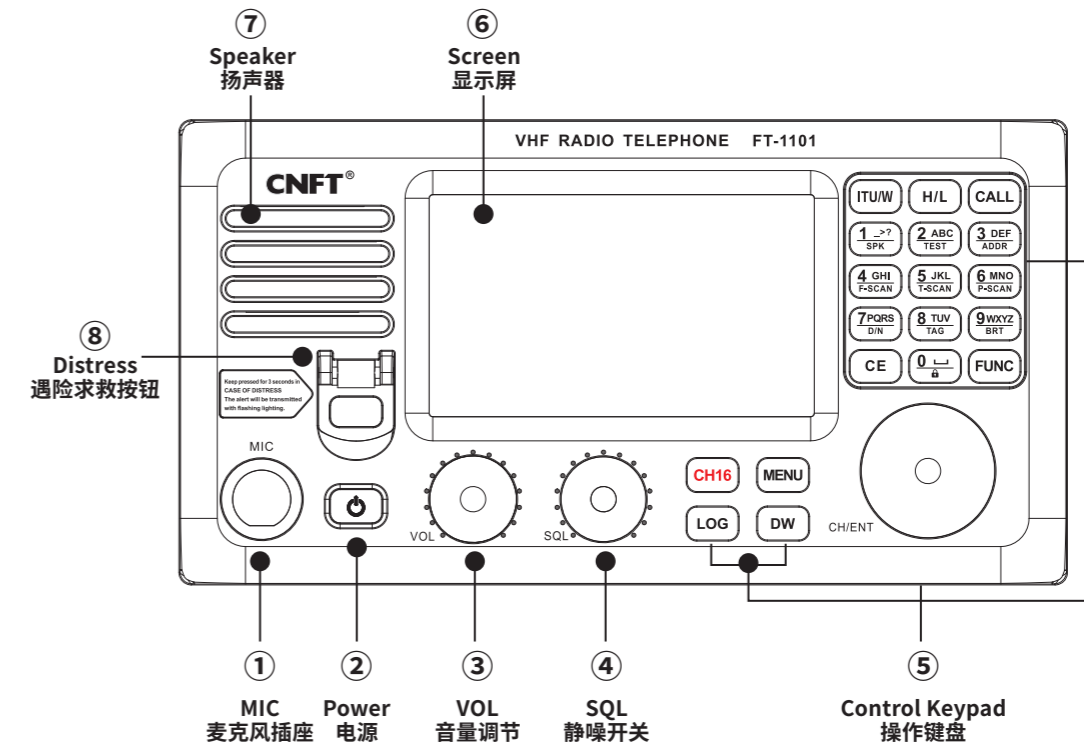

显示单元后视图说明

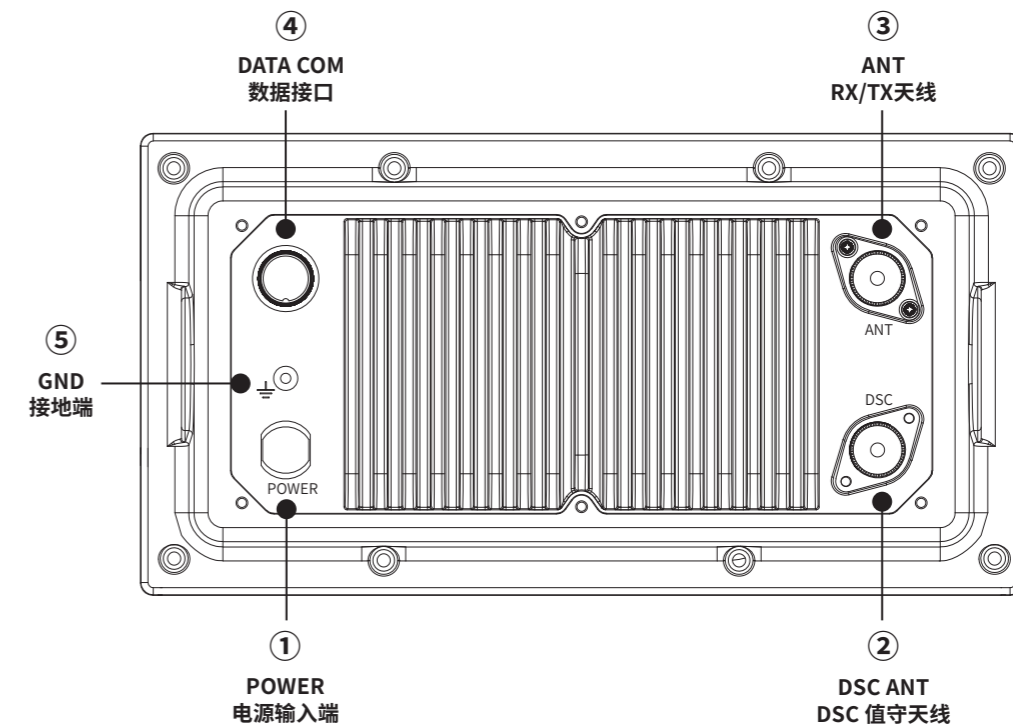

■ 显示单元后视图接口规格

① POWER(电源输入接口)

※注明：电源输入接口 (12V (10.8V-15.6V) DC: 5A)

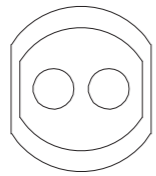

红色：电源输入端(+)
黑色：电源输入端(-)

② DSC ANT(DSC值守天线接口)

③ ANT(RX/TX ANT接收和发射天线)

④ DATA COM(数据接口)

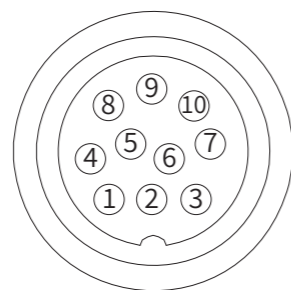

序号	定义	功能
1	VDR_A	航行数据输出A
2	GND	地
3	GNSS_RX+	定位输入+
4	EXT_ALARM+	报警接口+
5	EXT_ALARM-	报警接口-
6	VDR_B	航行数据输出B
7	GNSS_RX-	定位输入-
8	RS232_WXD	打印机输出
9	EXP_SPK-	音频输出-
10	EXP_SPK+	音频输出+

⑤ GND(整机接地端口)

附录

◆ 附录A：美国频段频率表 (USA)

频道号	频率 (MHZ)		频道号	频率 (MHZ)	
	发射频率	接收频率		发射频率	接收频率
1001	156.050	156.050	60		
2			61		
3			62		
4			1063	156.175	156.175
1005	156.250	156.250	64		
6	156.300	156.300	1065	156.275	156.275
1007	156.350	156.350	1066	156.325	156.325
8	156.400	156.400	67 *L	156.375	156.375
9	156.450	156.450	68	156.425	156.425
10	156.500	156.500	69	156.475	156.475
11	156.550	156.550	70 *D	156.525	156.525
12	156.600	156.600	71 *L	156.575	156.575
13 *L	156.650	156.650	72	156.625	156.625
14	156.700	156.700	73	156.675	156.675
15	*RX only	156.750	74	156.725	156.725
16	156.800	156.800	75		
17 *L	156.850	156.850	76		
1018	156.900	156.900	77 *L	156.875	156.875
1019	156.950	156.950	1078	156.925	156.925
20	157.000	161.600	1079	156.975	156.975
1020	157.000	157.000	1080	157.025	157.025
1021	157.050	157.050	1081	157.075	157.075
1022	157.100	157.100	1082	157.125	157.125
1023	157.150	157.150	1083	157.175	157.175
24	157.200	161.800	84	157.225	161.825
25	157.250	161.850	85	157.275	161.875
26	157.300	161.900	86	157.325	161.925
27	157.350	161.950	87	157.375	157.375
28	157.400	162.000	88	157.425	157.425

* L:仅低功率 * D:DSC频段 *RX only:禁止发射

◆ 附录B: 国际频段频率表 (INT)

频道号	频率 (MHZ)		频道号	频率 (MHZ)	
	发射频率	接收频率		发射频率	接收频率
1	156.050	160.650	60	156.025	160.625
2	156.100	160.700	61	156.075	160.675
3	156.150	160.750	62	156.125	160.725
4	156.200	160.800	63	156.175	160.775
5	156.250	160.850	64	156.225	160.825
6	156.300	156.300	65	156.275	160.875
7	156.350	160.950	66	156.325	160.925
8	156.400	156.400	67	156.375	156.375
9	156.450	156.450	68	156.425	156.425
10	156.500	156.500	69	156.475	156.475
11	156.550	156.550	70 *D	156.525	156.525
12	156.600	156.600	71	156.575	156.575
13	156.650	156.650	72	156.625	156.625
14	156.700	156.700	73	156.675	156.675
15 *L	156.750	156.750	74	156.725	156.725
16	156.800	156.800	75 *L	156.775	156.775
17 *L	156.850	156.850	76 *L	156.825	156.825
18	156.900	161.500	77	156.875	156.875
19	156.950	161.550	78	156.925	161.525
1019	156.950	156.950	1078	156.925	156.925
2019	*RX only	161.550	2078	*RX only	161.525
20	157.000	161.600	79	156.975	161.575
1020	157.000	157.000	1079	156.975	156.975
2020	*RX only	161.600	2079	RX only	161.575
21	157.050	161.650	80	157.025	161.625
22	157.100	161.700	81	157.075	161.675
23	157.150	161.750	82	157.125	161.725
24	157.200	161.800	83	157.175	161.775
25	157.250	161.850	84	157.225	161.825
26	157.300	161.900	85	157.275	161.875
			86	157.325	161.925
1027	157.350	157.350	87	157.375	157.375
1028	157.400	157.400	88	157.425	157.425

* L:仅低功率 * D:DSC频段 *RX only:禁止发射

◆ 附录C: 加拿大频段频率表 (CAN)

频道号	频率 (MHZ)		频道号	频率 (MHZ)	
	发射频率	接收频率		发射频率	接收频率
1001	156.050	156.050	60		
2			61		
3			62		
4			1063	156.175	156.175
1005	156.250	156.250	64		
6	156.300	156.300	1065	156.275	156.275
1007	156.350	156.350	1066	156.325	156.325
8	156.400	156.400	67 *L	156.375	156.375
9	156.450	156.450	68	156.425	156.425
10	156.500	156.500	69	156.475	156.475
11	156.550	156.550	70 *D	156.525	156.525
12	156.600	156.600	71 *L	156.575	156.575
13 *L	156.650	156.650	72	156.625	156.625
14	156.700	156.700	73	156.675	156.675
15	*RX only	156.750	74	156.725	156.725
16	156.800	156.800	75		
17 *L	156.850	156.850	76		
1018	156.900	156.900	77 *L	156.875	156.875
1019	156.950	156.950	1078	156.925	156.925
20	157.000	161.600	1079	156.975	156.975
1020	157.000	157.000	1080	157.025	157.025
1021	157.050	157.050	1081	157.075	157.075
1022	157.100	157.100	1082	157.125	157.125
1023	157.150	157.150	1083	157.175	157.175
24	157.200	161.800	84	157.225	161.825
25	157.250	161.850	85	157.275	161.875
26	157.300	161.900	86	157.325	161.925
27	157.350	161.950	87	157.375	157.375
28	157.400	162.000	88	157.425	

* L:仅低功率 * D:DSC频段 *RX only:禁止发射 *CH20xx等同于CHxxB

◆ 附录D：天气频段频率表 (WX)

频道号	频率 (MHZ)	
	发射频率	接收频率
01	*RX only	162.550
02	*RX only	162.400
03	*RX only	162.475
04	*RX only	162.425
05	*RX only	162.450
06	*RX only	162.500
07	*RX only	162.525
08	*RX only	161.650
09	*RX only	161.775
10	*RX only	163.275
11	*RX only	149.225
12	*RX only	149.850
13	*RX only	160.650

*RX only:禁止发射

设备维护

现象	可能原因	排除方法
无法开机	电源接反;电源线未插紧; 设备输入电压超压	检查电源连接方向,重新正确连接; 插紧电源线; 确认设备输入电压在设备工作电压范围内
发射功率不足	天线安装不到位,如松动、角度偏差; 周围有遮挡物影响信号	重新安装天线,确保稳固且角度合适; 移除天线周围的遮挡物
接收信号弱或无信号	天线未正确连接; 天线被异物缠绕	检查天线连接部位,重新连接; 清理天线周围的异物
通信杂音大	设备未接地; 附近有干扰源,如其他电器设备	为设备正确接地; 将设备远离干扰源

◇ 定期检查

请定期对仪器进行以下必要项目的检查,这将有助于仪器保持良好的性能。

项目	现象	操作方法
电源电缆	暴露、破损	更换
电源插头	松动	插紧
显示部件	腐蚀	清洁
供电电压	过压、欠压	检查供电系统

◇ 整机的清洁

仪器表面的灰尘和污渍可以用软布擦除,如果必要,也可以用湿润的软布进行清洁。擦拭液晶表面时,请特别注意,因为它容易被擦伤。不要使用化学清洁剂,因为它们可能会把仪器表面的漆或标记擦掉。