

CNFT®

OPERATOR'S MANUAL

FT-1100

甚高频(A级DSC)无线电装置

VHF Radio Device (Class A DSC)

福建飞通通讯科技股份有限公司

[FUJIAN FEITONG COMMUNICATION TECHNOLOGY CO., LTD.]

Tel/ +86-595-88481988
Web/ www.cnfeitong.com
Version/ V1.0.0

地址/ 福建省石狮市高新技术开发区电子信息园飞通科技大厦
Addr/ Feitong Technology Building, Electronic Information Park, Hi-Tech
Industrial Development Zone, Shishi City, Fujian Province, China.

福建飞通通讯科技股份有限公司

FUJIAN FEITONG COMMUNICATION TECHNOLOGY CO., LTD.

Safety Instruction

Danger!

- If any object falls into the device or water splashes onto it, immediately turn off the power at the distribution panel.
(Continued use may cause fire or electric shock)
- If the device emits smoke or catches fire, immediately turn off the power at the distribution panel.
(Continued use may cause fire or electric shock)
- If the device operates abnormally, immediately turn off the power at the distribution panel.
(Continued use may cause fire or electric shock; it is recommended to contact the agent/ distributor for consultation)

Warning!

- Be sure to turn off the power at the distribution panel before starting installation.
(Power-on during installation may cause fire or electric shock)
- Use only the specified power cable.
(Using other cables may cause fire or electric shock)
- Do not install the device in locations where it may be exposed to rain or splashing water.
(Water entering the device may cause fire or electric shock)
- Do not place containers filled with liquid on top of the device. (May cause fire or electric shock)
- Do not operate the device with wet hands. (May cause electric shock)
- Do not disassemble or modify the device. (May cause electric shock, fire, or personal injury)

Caution!

- Ensure the power supply voltage is compatible with the device's rated voltage. Incorrect power connection may cause fire or equipment damage. The rated voltage is indicated on the label on the back of the display unit.
- Handle the grounding copper strap with care; its edges may injure your hands.
- Maintain a minimum compass safe distance of 60MM.
- Grounding the device: Ungrounded equipment may emit or receive electromagnetic interference, or cause electric shock.



Warning!

- Do not perform operations inside the device unless fully familiar with electrical circuits.
- Hazardous voltages exist inside the device that may cause electric shock.

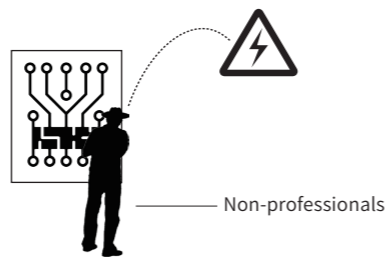

- Before starting installation, turn off the power at the main distribution panel. Post a sign near the switch indicating that the power should not be turned on during installation. Failure to turn off or accidental activation of power during installation may result in fire, electric shock, or serious injury.

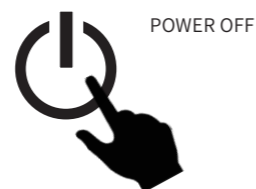

- Do not operate the distress button unless the vessel is in actual distress. (Activating the distress button will transmit a distress signal; if sent accidentally, immediately contact the coast radio station to report)

Contents

■ Safety Instruction.....	01
■ Preface	03
■ Main Technical Specifications.....	03
■ Installation Guide	04-09
■ Panel Description	10-12
■ Basic Operations	13-14
Power On.....	13
Change Channels.....	13
Transmit and Receive Radio Signals.....	13
Dual Watch.....	13
How to Play a Recording.....	13
How to Quickly Send a DSC Test Call.....	13
Full Channel Scan.....	14
Tagged/Memory Channel Scan.....	14
Priority Channel Scan.....	14
Display Modes.....	14
Tag/Remember the Current Channel.....	14
How to Adjust Screen Backlight and key Backlight Brightness.....	14
■ Distress Alert Operation	15-18
Distress Alert Call.....	15
Distress Alert Relay Call.....	17
■ Routine Call Operation	19-30
Individual Call.....	19
All Ship Call.....	21
Group Call.....	22
Telephone Call.....	23
Position Request Call.....	25
Test Call.....	27
Data Call.....	28
Neutral Ship Call.....	29
Medical Ship Call.....	30
Query Call.....	30
■ Menu Operation	31-42
How to Use the Menu.....	31
Editing User Channels.....	31
Address Book.....	32
Call Files.....	33
Call Log.....	33
System Settings.....	34
Digital Selective Calling (DSC) Settings.....	39
Clearing Memory.....	42
Self-Test.....	42
Service Information.....	42
■ GNSS Device Connection	43
■ Interface Specification	44-46
■ Appendix	47-50
■ Maintain	51
■ 操作手册中文版	52(起)

Preface

Thank you for choosing our product, Model: FT-1100, Name: Very High Frequency (VHF) Radiotelephone (Class A DSC). The product includes the main unit and accessories provided as standard; please refer to the Packing List for details. Before installing and using this product, please carefully read the User Manual to prevent damage caused by improper operation or lack of professional handling, which may lead to equipment failure or personal safety risks. Our company does not assume any liability for consequences arising from improper use. **※ Note: If product upgrades or updates result in discrepancies between the User Manual and actual device operation, the device specifications shall prevail.**

Main Technical Specifications

The name of the project	Technical parameters
Power Supply	DC 24V +30/-10%
Channel Capacity	57 international maritime channels, along with an expansion of 200 private channels.
Frequency Interval	25KHz
Frequency Generation Method	Frequency synthesis
Radio Receiver	The device uses a double conversion superheterodyne design and multichannel reception. Frequency Range: 156.025Mhz-163.275Mhz IF Frequencies: 21.7MHz; 450KHz; Maximum Usable Sensitivity: 0.5uV of 20dB/SINAD Adjacent Channel Selectivity: ≥70dB; Spurious Response Rejection: ≥70dB Intermodulation Rejection: ≥68dB Spurious Radiation: ≤2nW; Current: 0.9Amps (MaxAudio), 0.4Amps (STBY) Audio Frequency Response: +1, -3dB of +6dB/octave (300-3000Hz) Noise Level: ≤-40dB; Signal-to-noise ratio: ≥40dB; Blocking: ≥90dB Audio Output: 2W (8Ohm, less than 10% distortion)
Channel 70 DSC Receiver	Frequency: CH70 (156.525MHz); Frequency Error: ≤10Hz(1300Hz和2100Hz) Sensitivity: 1uV (with a bit error rate of less than 1%) Bandwidth: 16KHz; IF frequency: 17.9MHz; Second IF: 455KHz Adjacent Channel Selectivity: ≥70dB; Spurious Response Rejection: ≥70dB Intermodulation Rejection: ≥65dB; Reception Mode: G2B Spurious Radiation: ≤2nW, 9KHz to 2GHz
Radio Transmitter	Modulation Type: G3E (Voice), G2B (DSC); Frequency Range: 156.025Mhz-157.425Mhz Output Power: 25W, 1W (50 Ohms); Audio Harmonic Distortion: ≤10% Audio Frequency Response: +1/-3dB of +6dB/octave, Pre-emphasis 300 - 3000Hz Residual Modulation: ≤-40dB; Frequency Deviation: ≤5KHz at maximum peak Spurious Radiation: ≤0.25μW; Current: ≤5Amps (max)

Installation Guide

Electrical Installation

Before operating the device, ensure proper connection of the power supply, antenna, and any external equipment. The device requires a **12V DC power supply** with an output current of at least 5A.

System Connection Diagram

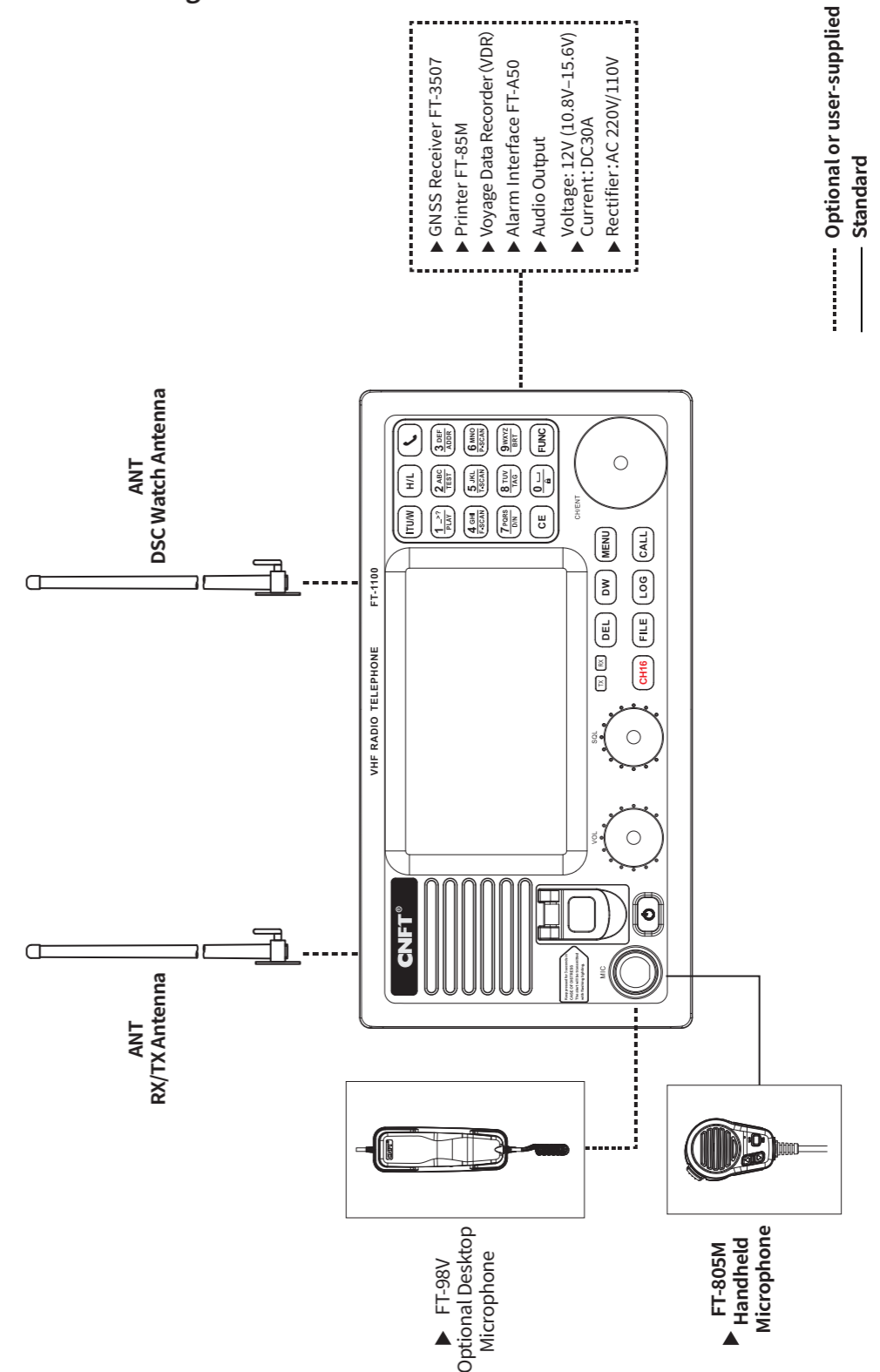

Fixed Installation

- ※ The product should be installed in a well-ventilated area, away from the engine.
- ※ Do not install the product in direct sunlight.
- ※ Keep the product at least 1 meter away from the compass.

The product is equipped with an adjustable mounting bracket, secured with five screws. Before installation, ensure a clearance of 100mm vertically and 70mm horizontally behind the bracket for proper adjustment. The tilt angle of the product can be adjusted using the clamp.

Desktop Mounting

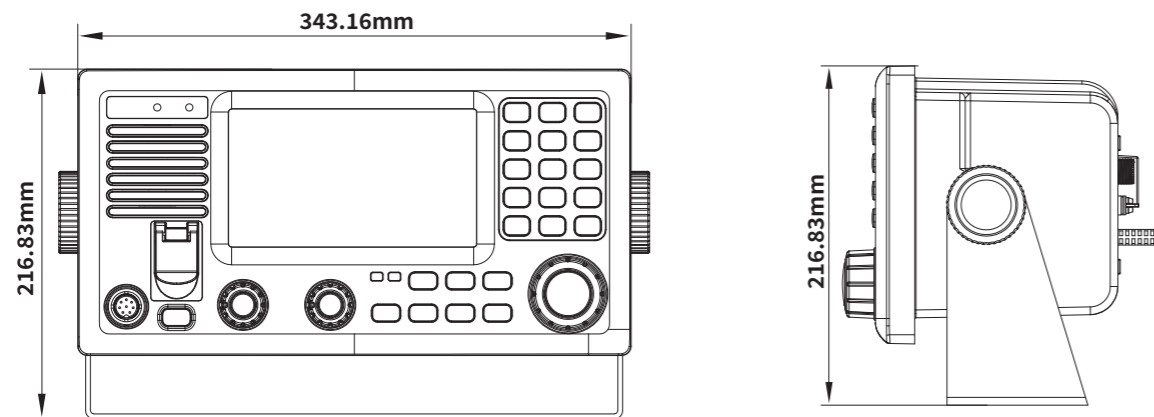

Overhead Mounting

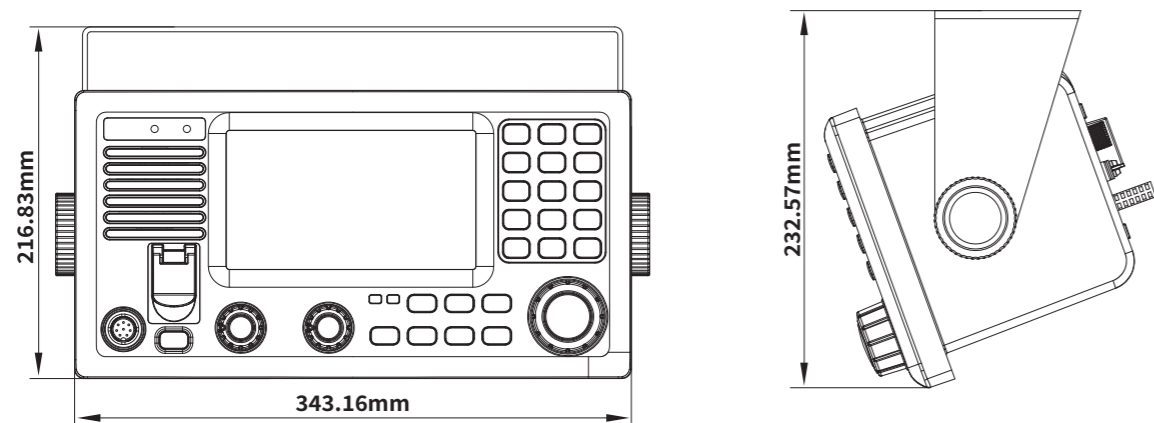

Embedded Mounting

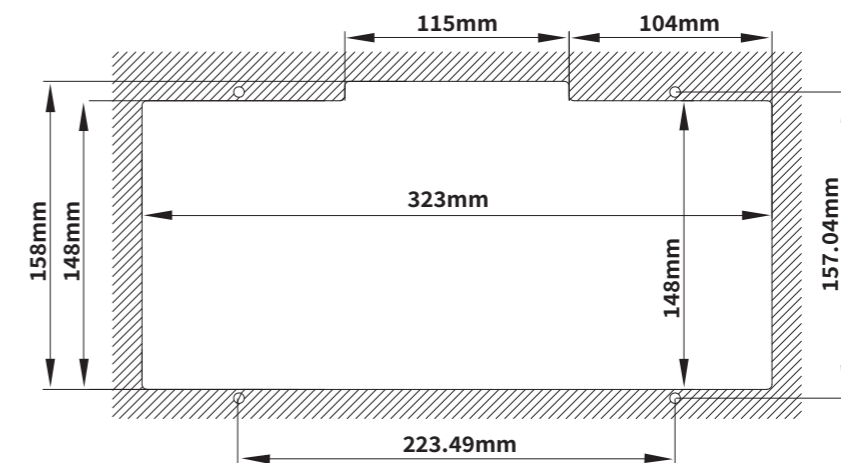
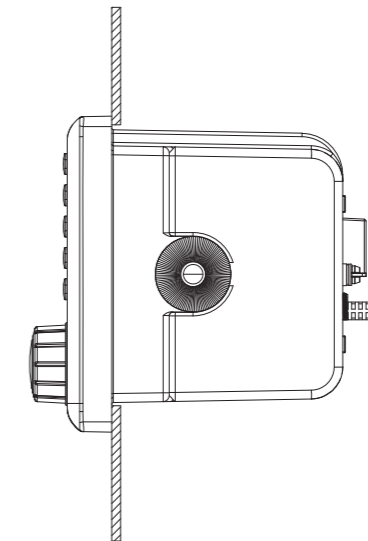
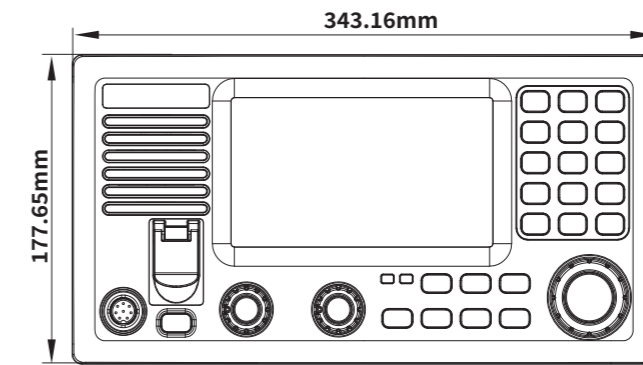

Front View

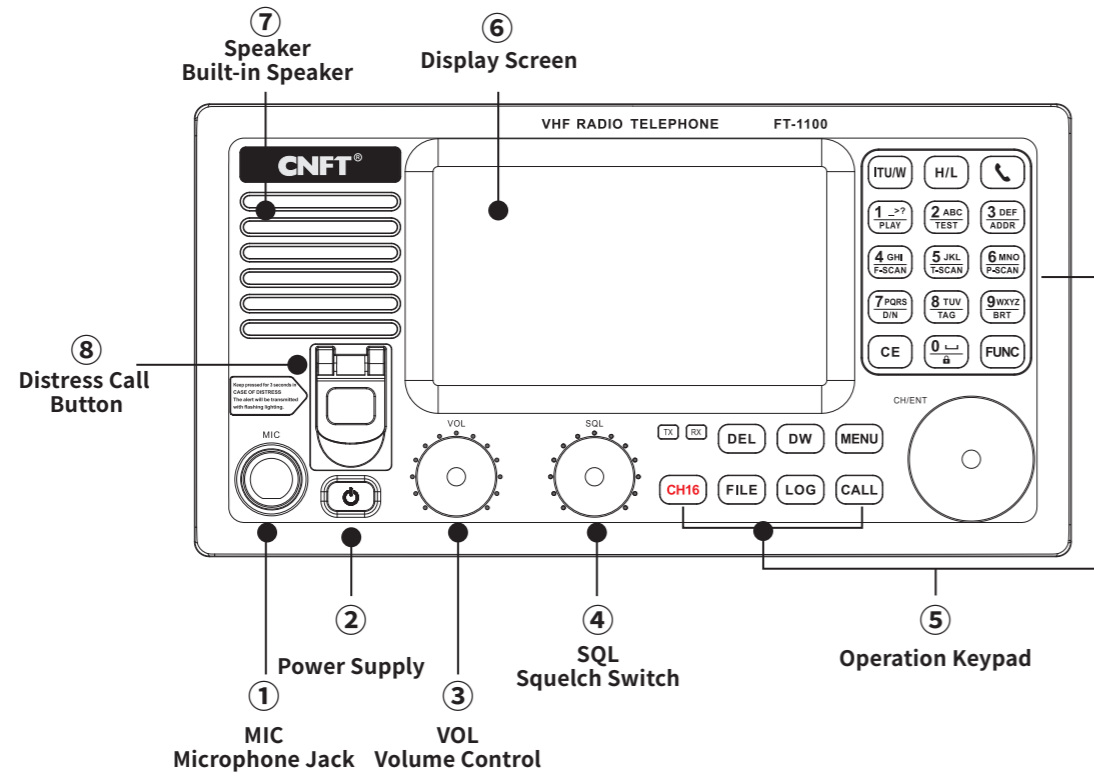

Rear View

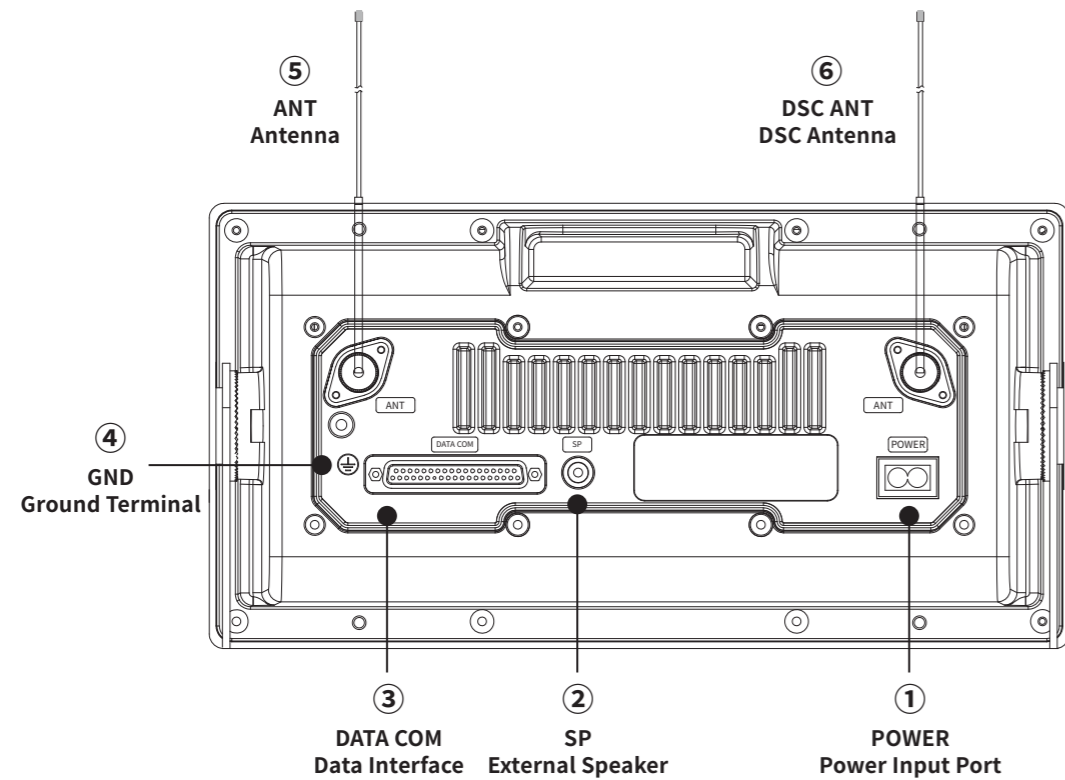

Assembly Diagram

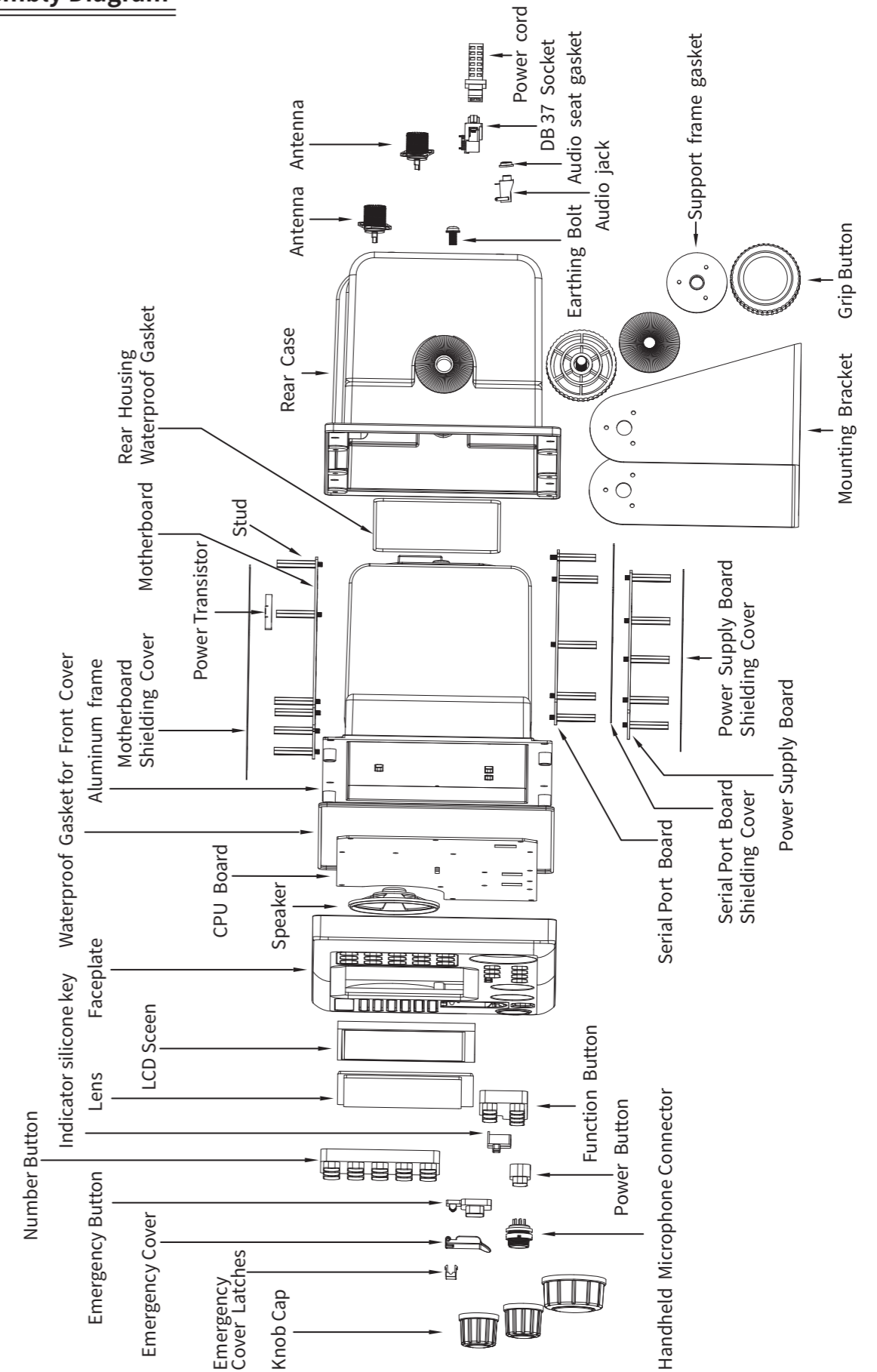

Antenna Installation

Antenna Installation Diagram

Proper antenna installation is crucial for minimizing interference and achieving optimal communication range. Please note the following points during installation:

- ① The antenna should be mounted in a vertical position and kept as far as possible from conductive objects on a horizontal plane. The minimum distance should not be less than 0.5 meters. The antenna should not be placed near large vertical objects and must maintain 360° unobstructed clearance.
- ② The antenna should be kept away from high-power transmitters, such as radar, radio stations, or other wireless antennas. Ideally, maintain a minimum distance of 3 meters.
- ③ Two antennas should not be installed on the same side. If they must be on the same side, ensure a minimum spacing of 10 meters. If conditions do not allow, install the antennas vertically, with a height difference of at least 2.5 meters.
- ④ Outdoor cable interfaces must be waterproofed.
- ⑤ Antenna cable length should be kept as short as possible and should be kept away from power cables. If crossing power cables, maintain a 90° perpendicular angle.
- ⑥ If installing on a light pole, use insulating materials for isolation and ensure the height is at least 1.5 meters above ground.

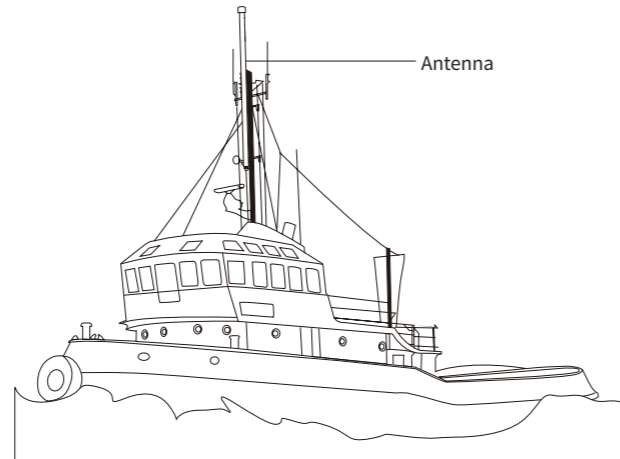

Whip Antenna Installation Diagram

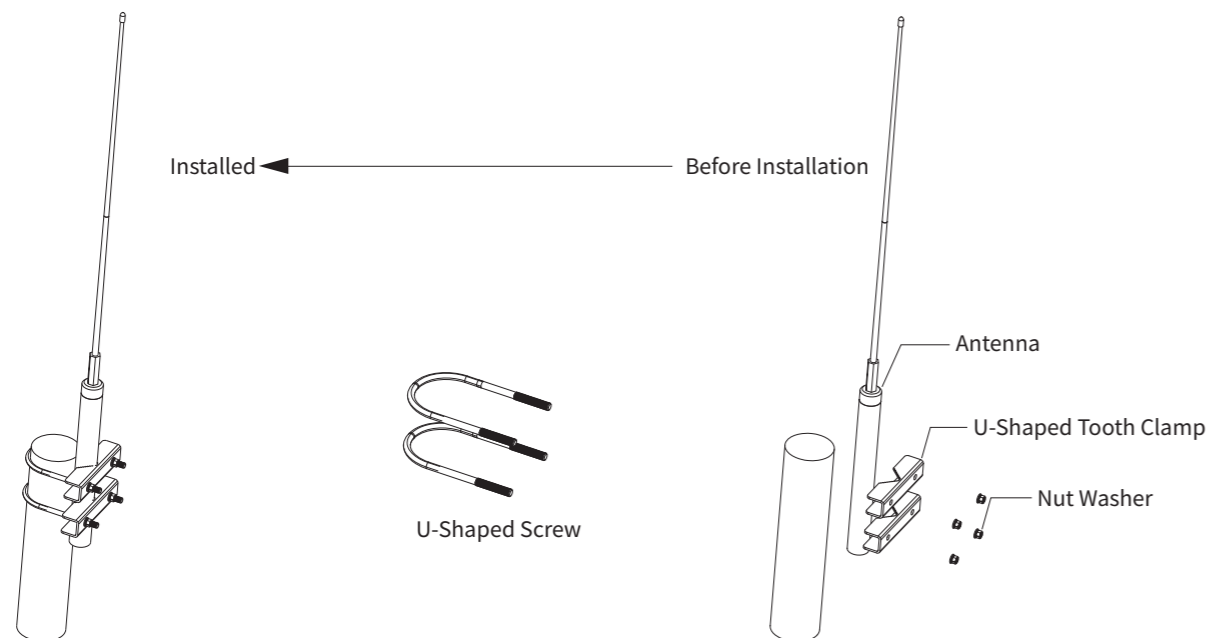

Panel Description

The FT-1100 VHF Radiotelephone (Class A DSC) is a multi-functional radio equipped with DSC capabilities, supporting features such as band switching, scanning, watchkeeping, and private channels. The device is built with an aluminum alloy frame, high-quality components, waterproof protection, and a reliable combination of hardware and software technologies. A large LCD screen and intuitive button interface enhance usability.

Front Panel Layout

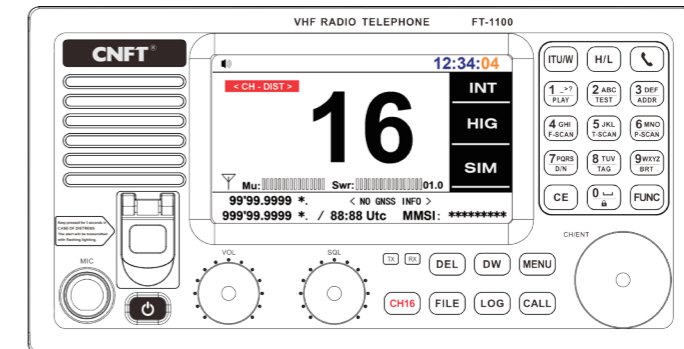

Keyboard Functionality

FUNC	Enable the multifunction of numeric keys. When pressed, the display shows "FUNC," and pressing a numeric key activates its multifunction.
1 ..->? PLAY	Default function <1>, multifunction <PLAY>; Multifunction: Enable/disable built-in speaker output.
2 ABC TEST	Default function <2>, multifunction <TEST>. Multifunction: Open DSC test call editing interface to send/save the call.
3 DEF ADDR	Default function <3>, multifunction <ADDR>; Multifunction: Open the address book list.
4 GHI F-SCAN	Default function <4>, multifunction <F-SCAN>; Multifunction: Enable full channel scan.
5 JKL T-SCAN	Default function <5>, multifunction <T-SCAN>; Multifunction: Enable tagged/memory channel scan.
6 MNO P-SCAN	Default function <6>, multifunction <P-SCAN>; Multifunction: Enable priority channel scan.
7 POR DN	Default function <7>, multifunction <DN>. Multifunction: Switch the main interface theme mode. DAY for day mode (white background, black text), NIGHT for night mode (black background, white text).
8 TUV TAG	Default function <8>, multifunction <TAG>; Multifunction: Tag/memorize the current channel.
9 WXYZ BRT	Default function <9>, multifunction <BRT>; Multifunction: Open the backlight brightness adjustment dialog.
0 LOCK	Default function <0>, multifunction <LOCK>. Multifunction: Lock key/knob operations. When enabled, the display shows "LOCK." When this function is enabled, the display will show a "LOCK" icon (keyboard prompt). At this time, the buttons and knobs will not respond. Press this key again to unlock, and the "LOCK" icon (prompt) disappear.
SPKER	Built-in Speaker

DISTRESS	Open the red protective cover, then press and hold this button for 5 seconds, and the device will send a distress call.
MIC	Microphone Jack
POWER	Power Switch : After correctly connecting the power, press and hold for 3 seconds to turn on or off.
VOL	Volume Control : Adjust the volume output level, turn right to increase the volume, turn left to decrease the volume.
SQL	Squelch Control: Adjust the receiver squelch level, turn right to increase squelch, turn left to decrease squelch.
CH16	Quickly switch to CH16 channel.
DEL	Delete Key
DW	Enable dual watch function.
MENU	Open the main system menu.
File	Open the saved pre-edited call file.
LOG	Open the DSC log.
CALL	Open the call list menu to edit/send/save calls.
CHANNEL	Channel Knob: Select the working channel on the main interface; select the cursor position in the menu. Press to function as the [ENT] key.
ITU/W	Select the frequency band. Press to cycle through international (INT), USA (USA), Canada (CAN), and weather (WX) bands. Selecting INT, USA, or CAN will automatically switch to CH16. Selecting WX will switch to CH01.
H/L	Switch power, high power (HIGH) -> 25W, low power (LOW) -> 1W.
	Internal Call Request Key for Remote Handst.
CE	Cancel the current operation and return to the previous menu.
LCD	10.7-inch TFT Display

◇ Display Interface

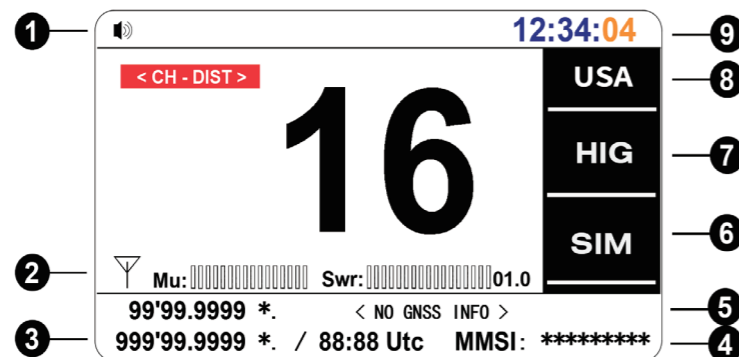

◇ Display Interface Instruction Manual

NO.	Description
1	speaker status
2	Received signal strength/transmit output power indicator. MU → Standby Status TX → Transmission Status RX → Reception Status Swr → Antenna Standing Wave Ratio during Transmission
3	GNSS information of the device.
4	9-digit MMSI number of the device.
5	GNSS information input status of the device.
6	Current channel attribute signal: SIM → RX_freq = TX_freq DUP → RX_freq != TX_freq
7	Current channel output power status: HIGH → 25W LOW → 1W NO-TX → Transmission prohibited on this channel.
8	Current frequency band information: INT → International band UAR. → USA band CAN → Canada band WX → Weather band
9	Local RTC time.

Basic Operations

◆ Power On

After correctly connecting the power, press and hold for 3 seconds to turn on or off.

◆ Change Channels

Rotate the [CHANNEL] knob to change channels, or directly press the [numeric] keys to input the target channel and then press the [ENT] key to confirm.

◆ Transmit and Receive Radio Signals

Receiving: After powering on, the device enters standby mode, displaying "MU" on the screen. If a signal is received on the current channel, the screen will display "RX" and "BUSY" in green, and the signal strength indicator will vary according to the signal strength.

Transmitting: When the [PTT] button on the microphone is pressed, the device enters transmission mode, displaying "TX" in red on the screen. The power output indicator will vary according to the transmission power.

◆ Dual Watch

Dual watch function: alternately scans between the current channel and CH16.

Press the [DW] button on the panel to start dual watch scanning, and the screen will display "DW" icon.

If a signal is detected on the watch channel, the device will continue scanning without staying on the watch channel.

If a signal is detected on CH16, the device will stay on CH16 to continue monitoring the signal until it disappears. After the signal disappears for 30 seconds, the device will resume scanning. During this period, the operator can press the [PTT] button to speak, and the device will exit dual watch.

Press the [CE] button to cancel the watch scan.

◆ How to Play a Recording

First, press the [FUNC] key on the panel, then press the [1/Play] key to open the recording playback interface.

Use the channel knob to select the date for playback by turning it clockwise/counterclockwise.

Press the [ENT] key to open the date directory. Use the channel knob again to select the recording file to be played back, then press the [ENT] key to start/pause playback.

Press the [CE] key to close the recording played interface.

◆ How to Quickly Send a DSC Test Call

First, press the [FUNC] key on the panel, then press the [2/TEST] key to open the call ending interface.

For detailed operation please refer to Section 5.6 of this manual.

◆ Full Channel Scan

Full scan function: scans all channels in the current frequency band.

First, press the [FUNC] key on the panel, then press the [4/F-SCAN] key. The device will scan all channels in the current frequency band, including private channels (private channels must be set / tagged in advance). The scan sequence can be set to scan up or down by rotating the channel knob on the microphone. When the device detects a signal on a channel, it will stay on that channel to monitor the signal until it disappears. After the signal disappears for 30 seconds, the device will resume scanning. During this period, the operator can press the [PTT] key to speak, and the device will exit the scan. Press the [CE] key to cancel the full channel scan.

◆ Tagged/Memory Channel Scan

*Scan the tagged channels within the current frequency band.

First, press the [FUNC] key on the panel, then press the [5/T-SCAN] key. The device will scan the tagged channels within the current frequency band, including private channels (private channels must be set). The screen will display the "Tagged Scan" icon.

The scan sequence can be set to up/down scan by turning the channel knob clockwise/counterclockwise.

When the device detects a signal on a channel, it will stay on that channel and monitor the signal until it disappears. The device will resume scanning 30 seconds after the signal disappears. During the stay, the operator is allowed to press the [PTT] key to talk to the other party, and the device will exit the tagged scan. Press the [CE] key to cancel the tagged/memory channel scan.

◆ Priority Channel Scan

Priority channel scan function: alternately scans between the tagged channels and CH16 in the current frequency band.

First, press the [FUNC] key on the panel, then press the [6/P-SCAN] key to enable the priority channel scan function. The screen will display "SCAN," and the scan sequence can be set to scan up or down by rotating the channel knob on the microphone.

When a signal is detected on a tagged channel, the device will continue scanning without staying on the watch channel.

When the device detects a signal on a channel, it will stay on that channel and monitor the signal until it disappears. The device will continue scanning 30 seconds after the signal disappears. During the stay, the operator is allowed to press the [PTT] key to talk to the other party, and the device will exit the scan.

Press the [CE] key to cancel the priority channel scan.

◆ Display Modes

In the main interface, first press the [FUNC] key, then press the [7/DN] key to switch the display mode between day mode and night mode.

◆ Tag/Remember the Current Channel

First, press the [FUNC] key on the panel, then press the [8/TAG] key or directly press the [ENT] key to tag/remember the current channel.

◆ How to Adjust Screen Backlight and key Backlight Brightness

First, press the [FUNC] key on the panel, then press the [9/BRT] key to open the backlight brightness dialog box. Then, press the [FUNC] key again to select the backlight option to be adjusted. Finally, use the channel knob to adjust the backlight level by turning it clockwise/counterclockwise. Press the [CE] key to exit the dialog.

Distress Alert Call Operation

* DSC operations must be performed after the device has a valid MMSI number. If there is no valid MMSI number, pressing the [DIST] and [CALL] keys on the panel will trigger a warning message indicating the absence of an MMSI number. The following operations assume that the device has a valid MMSI number and is correctly connected to the GNSS device.

◆ Distress Alert Call

◇ Sending a Distress Alert Call

a: First, press the [DIST] key on the panel to open the distress alert call operation interface, as shown in Figure 4.1.1.

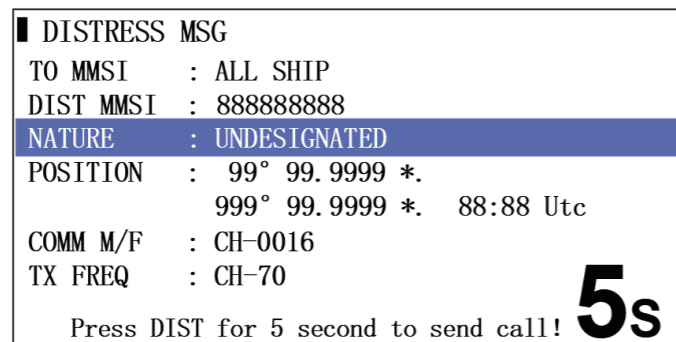

Figure4.1.1

b: Press the [ENT] key to open the NATURE list and use the channel knob to select the type of distress. The types of distress include: fire, flooding, collision, grounding, listing, sinking, loss of control, unspecified, abandoning ship, piracy, and man overboard, totaling 11 types. The default is unspecified.

Then press the [ENT] key to confirm.

c: The device allows the operator to manually input GNSS information. Rotate the channel knob to move the cursor to the <Distress Position> item, press the [number] keys to enter the correct GNSS information. Press the [DEL] key to delete if re-entry is needed. Then press the [ENT] key to confirm.

d: Press and hold the [DIST] key for 5 seconds to send a distress alert call. After 5 seconds, the distress alert call will be sent. After sending the distress alert call, the device enters the waiting for response call mode. In this mode, the device has switched to channel 16 and is ready for communication. It will repeat the alert sound at random intervals between 20 to 50 seconds. If no response call is received within 3.5 to 4.5 minutes, the device will automatically resend the distress alert call. Select the <STOP> item to stop automatic resending, or select the <RESEND> item to immediately resend the distress alert call.

If the device mistakenly sends a distress alert call, follow these steps to cancel the alert promptly:

- In the waiting for response call mode, select the [CE] key to send a cancel alert call and cancel the alert.
- Use the radio on channel 16 to report your information.

For example:

"All ships... All ships... All ships... This is (ship's name and call sign), MMSI is XXXXXXXXX, my position is XX degrees XX minutes, XXX degrees XX minutes, canceling my unspecified distress alert on XXXX-XX-XX at XX:XX."

c) Continue with other operations.

◇ Receiving a Distress Alert Response Call

When the device receives a distress alert response call, it will emit an alert sound and display the information contained in the response call, as shown in Figure 4.1.2. At the same time, the device will switch to channel 16 and wait for communication.

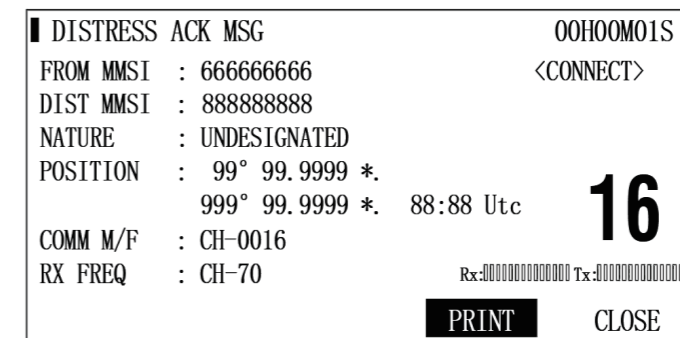

Figure4.1.2

◇ Receiving a Distress Alert Call

When the device receives a distress alert call, it will emit an alert sound and display the information contained in the alert call, as shown in Figure 4.1.3. At the same time, the device will automatically switch to channel 16 and wait for communication.

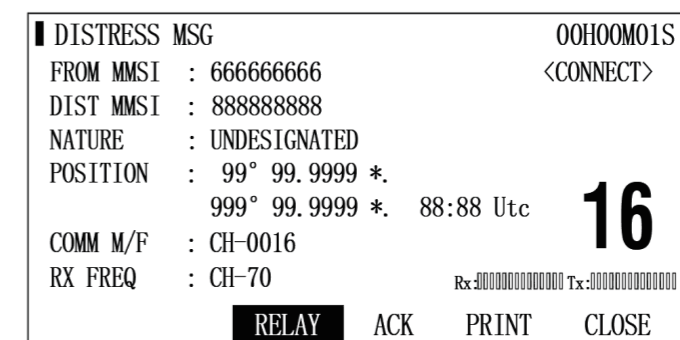

Figure4.1.3

To forward the alert, select the <RELAY> item, press the [ENT] key to open the relay type menu, choose to relay to a single station or all stations, and then press the [ENT] key to send the call. To send a distress alert response call, select the <ACK> item and press the [ENT] key to send the response call. Press the [CE] key or select <Close> to return to the main interface.

◆ Distress Alert Relay Call

◇ Relaying a Distress Alert to All Stations

a: Press the [CALL] key on the panel to open the call type list.
b: Use the channel knob to select the <DISTRESS RELAY ALL SHIP MSG> item, and press the [ENT] key to open the editing interface, as shown in Figure 4.2.1.

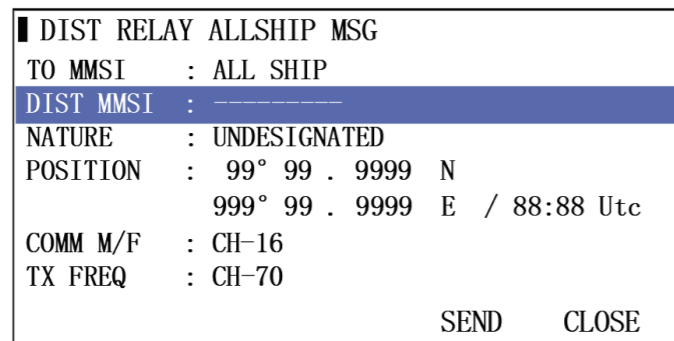

Figure4.2.1

c: Rotate the channel knob to select the <DIST MMSI> item, use the numeric keypad to enter the MMSI number of the distressed vessel, or press the [ENT] key to open the address book and select the MMSI number from it.
d: Rotate the channel knob to select the <Distress Type> item. The types of distress include: fire, flooding, collision, grounding, listing, sinking, loss of power, unspecified, abandoning ship, piracy, and man overboard, totaling 11 types. The default is unspecified type. Press the [ENT] key to confirm.
e: The device allows the operator to manually input GNSS information. Rotate the channel knob to select the <Distress Position> item, press the [Number] key to enter the correct GNSS information, and then press the [ENT] key to confirm.
f: Rotate the channel knob to select the <SEND> item, press the [ENT] key to send the distress alert relay call. After sending, the device will automatically switch to channel 16 and be ready for communication.

◇ Receiving a Distress Alert Relay Call to All Stations

Refer to section 4.1.3 for the operation of receiving a distress alert call.

◇ Relaying a Distress Alert to a Single Station

a: Press the [CALL] key on the panel to open the call type list.
b: Use the channel knob to select the <DISTRESS RELAY INDIVIDUAL MSG> item, and press the [ENT] key to open the editing interface, as shown in Figure 4.2.3.

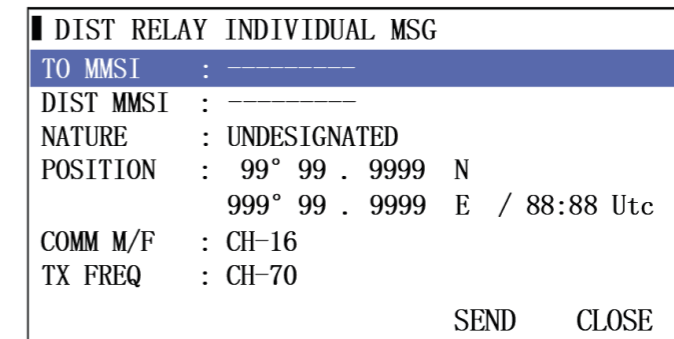

Figure4.2.3

c: Rotate the channel knob to select the <TO MMSI> item, use the numeric keypad to enter the MMSI number of the distressed vessel, or press the [ENT] key to open the address book and select the MMSI number from it.
d: Rotate the channel knob to select the <DIST MMSI> item, use the numeric keypad to enter the MMSI number of the distressed vessel, or press the [ENT] key to open the address book and select the MMSI number from it.
e: Rotate the channel knob to select the <Distress Type> item. The types of distress include: fire, flooding, collision, grounding, capsizing, sinking, loss of power, unspecified type, abandoning ship, piracy, and man overboard, totaling 11 types. The default is unspecified type. Press the [ENT] key to confirm.
f: The device allows the operator to manually input GNSS information. Rotate the channel knob to select the <Distress Position> item, press the [Number] key to enter the correct GNSS information (Press the [CE] key to delete if re-entry is needed), and then press the [ENT] key to confirm.
g: Rotate the channel knob to select the <SEND> item, press the [ENT] key to send the distress alert relay call. After sending, the device will switch to the waiting for response interface and automatically switch to channel 16, ready for communication.

◇ Receiving a Distress Alert Response Call Relayed to a Single Station

Refer to section 4.1.2 for the operation of receiving a distress alert response call.

◇ Receiving a Distress Alert Call Relayed to a Single Station

Refer to section 4.1.3 for the operation of receiving a distress alert call.

Routine Call Operations

* DSC operations must be performed after the device has a valid MMSI number. If there is no valid MMSI number, pressing the [DIST] and [CALL] keys on the panel will trigger a warning message indicating the absence of an MMSI number.

◆ Individual Call

◇ Sending an Individual Call

- a: Press the [CALL] key on the panel to open the call type list.
- b: Use the channel knob to select the <INDIVIDUAL MSG> item, and press the [ENT] key to open the editing interface, as shown in Figure 5.1.1.

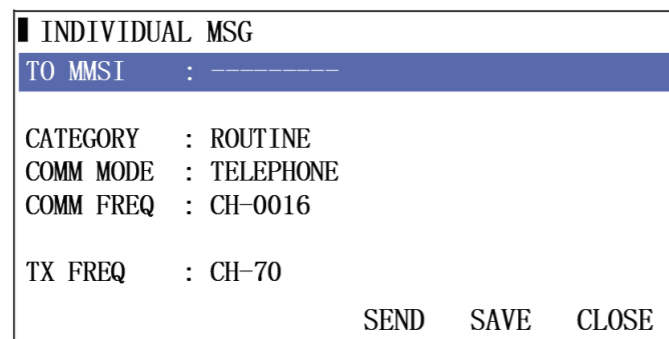

Figure5.1.1

- c: Rotate the channel knob to select the <TO MMSI> item, use the numeric keypad to enter the MMSI number of the target vessel, or press the [ENT] key to open the address book and select the MMSI number from it.
 - d: Rotate the channel knob to select the <CATEGORY> item, press the [ENT] key to open the call level list, select the desired level, and press the [ENT] key to confirm.
 - e: Rotate the channel knob to select the <COMM FREQ> item, use the [numeric] keys to enter the channel number.
 - f: Rotate the channel knob to select the <SEND> item, press the [ENT] key to send the call.
 - g: After sending the call, the device will wait for a response call. You can select the <RESEND> item and press the [ENT] key to resend the call.
- * Select the <SAVE> item to save the call to the call file.

◇ Receiving an Individual Response Call

When the device receives an individual response call, it will emit a prompt sound. The information contained in the response call will be displayed, as shown in Figure 5.1.2. At the same time, the device will switch to the communication channel and wait for communication.

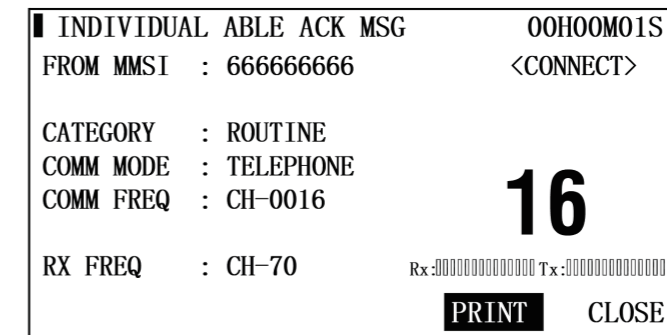

Figure5.1.2

- Select the <PRINT> item and press the [ENT] key to print the call.
- Select the <CLOSE> item and press the [ENT] key to close the interface and return to the main interface.

◇ Receiving an Individual Call

When the device receives an individual call, it will emit a prompt sound and display the information contained in the call, as shown in Figure 5.1.3.

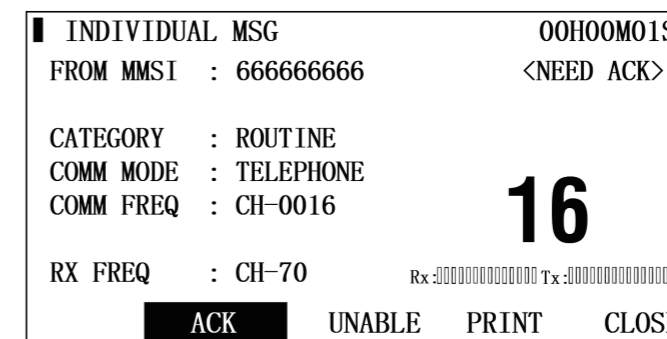

Figure5.1.3

- If a response is needed, select the <ACK> item and press the [ENT] key to send a response call. After sending, the device will automatically switch to the communication channel and be ready for communication.
- If a partial response is needed, select the <UNABLE> item and press the [ENT] key to open the partial response reason dialog. Choose the appropriate reason, press the [ENT] key to confirm, and send the partial response call. After sending, the device will return to the main interface.
- Select the <PRINT> item and press the [ENT] key to print the call.
- Select the <CLOSE> item and press the [ENT] key to close the interface and return to the main interface.

◆ All Ship Call

◇ Sending an All Ship Call

a: Press the [CALL] key on the panel to open the call type list.
b: Use the channel knob to select the <ALL SHIP> item, and press the [ENT] key to open the editing interface, as shown in Figure 5.2.1.

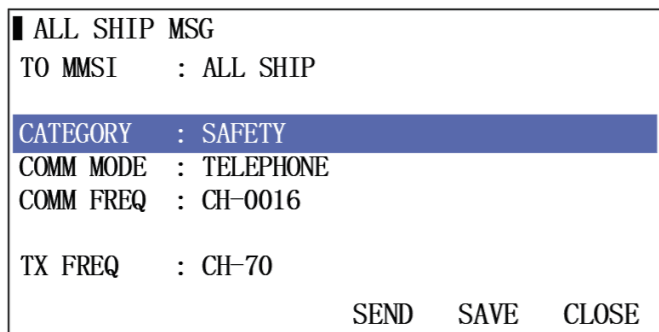

Figure5.2.1

c: Rotate the channel knob to select the <CATEGORY> item, press the [ENT] key to open the call level list, select the desired category, and press the [ENT] key to confirm.
d: Rotate the channel knob to select the <COMM FREQ> item, use the numeric keypad to enter the channel number.
e: Rotate the channel knob to select the <SEND> item, press the [ENT] key to send the call.
f: After sending the call, the device will switch to the communication channel and be ready for communication. You can also select the <RSEND> item and press the [ENT] key to resend the call.

◇ Receiving an All Ship Call

When the device receives an all Ship call, it will emit a prompt sound and display the information contained in the call, as shown in Figure 5.2.2.

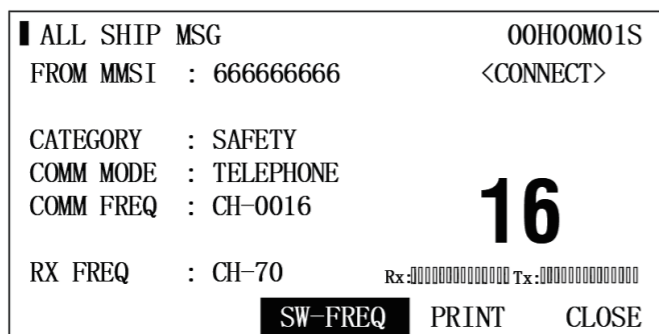

Figure5.2.2

If the frequency switching in the DSC menu is set to automatic mode, the device will automatically switch channels when a call is received. Otherwise, when a call is received, the current channel will not switch to the communication channel, and the user needs to select the <SW-FREQ> item and press the [ENT] key to switch to the communication frequency.

Select the <PRINT> item and press the [ENT] key to print the call.
Select the <CLOSE> item and press the [ENT] key to close the interface and return to the main interface.

◆ Group Call

◇ Sending a Group Call

a: Press the [CALL] key on the panel to open the call type list.
b: Use the channel knob to select the <GROUP MSG> item, and press the [ENT] key to open the editing interface, as shown in Figure 5.3.1.

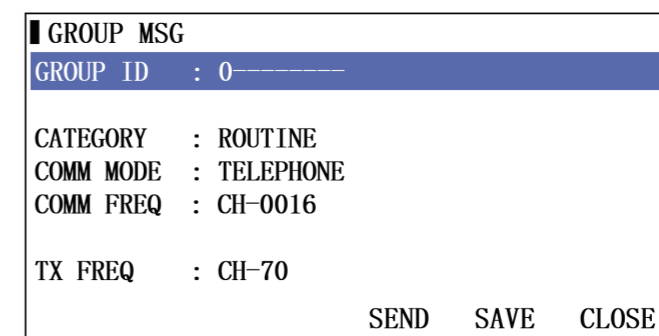

Figure5.3.1

c: Rotate the channel knob to select the <Call Target> item, use the numeric keypad to enter the group ID number, or press the [ENT] key to open the address book and select the group ID number from it.
d: Rotate the channel knob to select the <CATEGORY> item, press the [ENT] key to open the call category list, select the desired level, and press the [ENT] key to confirm.
e: Rotate the channel knob to select the <COMM FREQ> item, use the numeric keypad to enter the channel number.
f: Rotate the channel knob to select the <SEND> item, press the [ENT] key to send the call.
g: After sending the call, the device will switch to the communication channel and be ready for communication. You can also select the <RSEND> item and press the [ENT] key to resend the call.
* Group calls can only be set to routine call category.
* Select the <SAVE> item to save the call to the call file.

◇ Receiving a Group Call

When the device receives a group call, it will emit a prompt sound and display the information contained in the call, as shown in Figure 5.3.2.

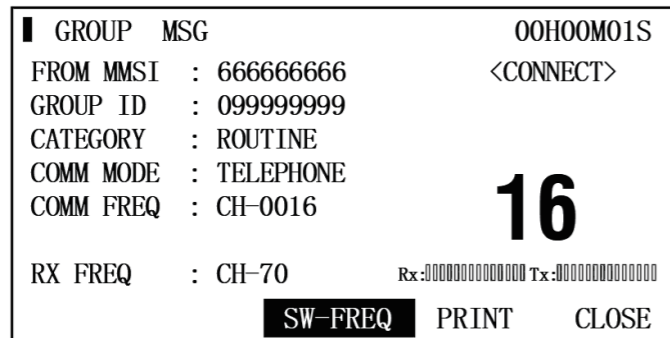

Figure5.3.2

If the frequency switching in the DSC menu is set to automatic mode, the device will automatically switch channels when a call is received. Otherwise, when a call is received, the current channel will not switch to the communication channel, and the user needs to select the <SW-FREQ> item.

press the [ENT] key to switch to the communication frequency.

Select the <PRINT> item and press the [ENT] key to print the call.

Select the <CLOSE> item and press the [ENT] key to close the interface and return to the main interface.

◆ Telephone Call

◇ Sending a Telephone Call

a: Press the [CALL] key on the panel to open the call type list.

b: Use the channel knob to select the <PSTN MSG> item, and press the [ENT] key to open the editing interface, as shown in Figure 5.4.1.

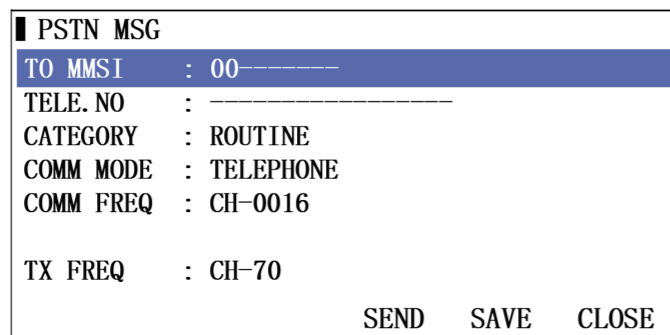

Figure5.4.1

c: Rotate the channel knob to select the <TO MMSI> item, use the numeric keypad to enter the MMSI number of the target, or press the [ENT] key to open the address book and select the MMSI number from it.

d: Rotate the channel knob to select the <TELE.NO> item, use the numeric keypad to enter the telephone number to be connected, or press the [ENT] key to open the address book and select the telephone number from it.

e: Rotate the channel knob to select the <SEND> item, press the [ENT] key to send the call.

f: After sending the call, the device will wait for a response call. You can select the <RESEND> item and press the [ENT] key to resend the call.

* Select the <SAVE> item to save the call to the call file.

◇ Receiving a PSTN Acknowledgment Call

When the device receives a PSTN acknowledgment call, it will emit a prompt sound. The information contained in the response call will be displayed, as shown in Figure 5.4.2. At the same time, the device will switch to the communication channel and wait for communication.

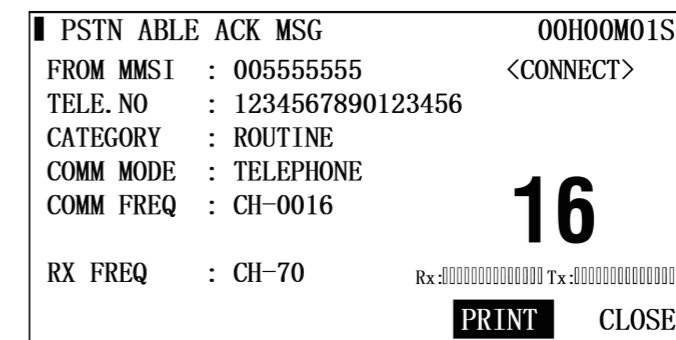

Figure5.4.2

Select the <PRINT> item and press the [ENT] key to print the call.

Select the <CLOSE> item and press the [ENT] key to close the interface and return to the main interface.

◇ Receiving a PSTN Call

When the device receives a PSTN call, it will emit a prompt sound and display the information contained in the call, as shown in Figure 5.4.3.

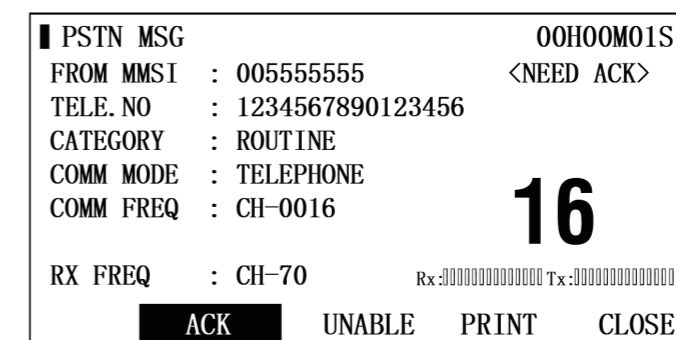

Figure5.4.3

If a response is needed, select the **<ACK>** item and press the **[ENT]** key to send a response call. After sending, the device will automatically switch to the communication channel and be ready for communication.

If a partial response is needed, select the **<UNABLE>** item and press the **[ENT]** key to open the partial response reason dialog. Choose the appropriate reason, press the **[ENT]** key to confirm, and send the partial response call. After sending, the device will return to the main interface.

Select the **<PRINT>** item and press the **[ENT]** key to print the call.

Select the **<CLOSE>** item and press the **[ENT]** key to close the interface and return to the main interface.

◆ Position Request Call

◇ Sending a Position Request Call

a: Press the **[CALL]** button on the panel to open the call type list.

b: Use the channel knob to select the **<POSITION MSG>** option, and press the **[ENT]** button to open the editing interface, as shown in Figure 5.5.1.

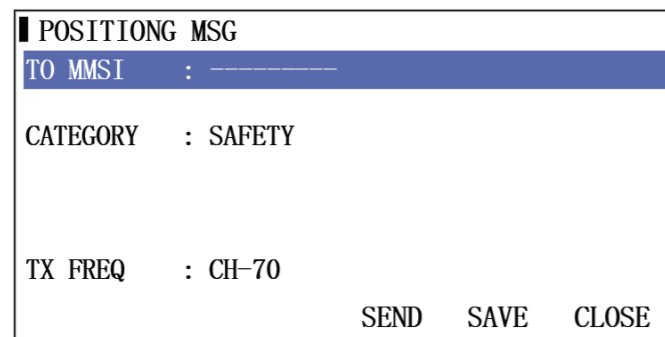

Figure5.5.1

c: Rotate the channel knob to select the **<TO MMSI>** option, use the numeric keypad to enter the MMSI number of the target vessel, or press the **[ENT]** button to open the address book and select the MMSI number from it;

d: Rotate the channel knob to select the **<SEND>** option, and press the **[ENT]** button to send the call.

e: After sending the call, the device waits for a response call. You can select the **<RESEND>** option and press the **[ENT]** button to resend the call.

* Select the **<SAVE>** option to save the call to the call file.

◇ Receiving a Position Request ACK

When the device receives a position request acknowledgment call, it will emit a prompt sound and display the information contained in the acknowledgment call, as shown in Figure 5.5.2.

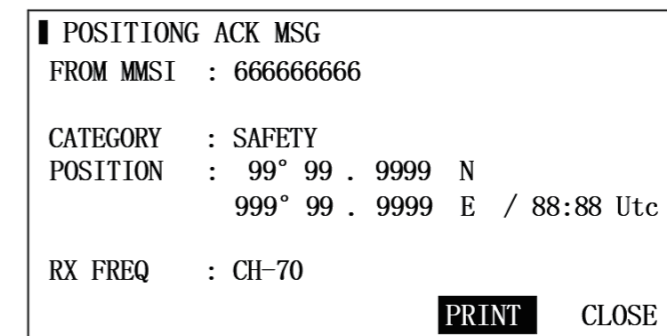

Figure5.5.2

Select the **<PRINT>** item and press the **[ENT]** key to print the call.

Select the **<CLOSE>** item and press the **[ENT]** key to close the interface and return to the main interface.

◇ Receiving a Position Request Call

When the device receives a position request call, it will emit a prompt sound and display the information contained in the call, as shown in Figure 5.5.3.

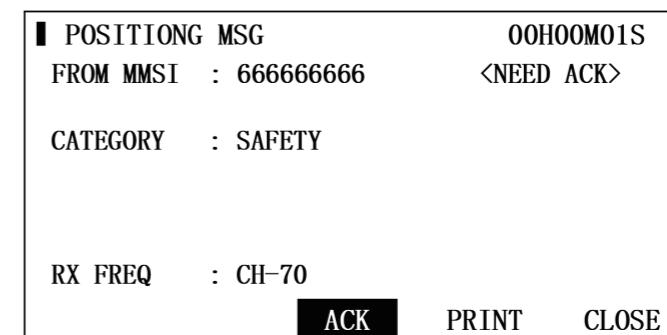

Figure5.5.3

Select the **<ACK>** item and press the **[ENT]** key to send a response call.

Select the **<PRINT>** item and press the **[ENT]** key to print the call.

Select the **<CLOSE>** item and press the **[ENT]** key to close the interface and return to the main interface.

◆ **Test Call**

◇ **Sending a Test Call**

- a: Press the [CALL] key on the panel to open the call type list.
 - b: Use the channel knob to select the <TEST MSG> item, and press the [ENT] key to open the editing interface, as shown in Figure 5.6.1.
 - c: Rotate the channel knob to select the <TO MMSI> item, use the numeric keypad to enter the MMSI number of the target vessel, or press the [ENT] key to open the address book and select the MMSI number from it.
 - d: Rotate the channel knob to select the <SEND> item, press the [ENT] key to send the call.
 - e: After sending the call, the device will wait for a response call. You can select the <RESEND> item and press the [ENT] key to resend the call.
- * Select the <SAVE> item to save the call to the call file.

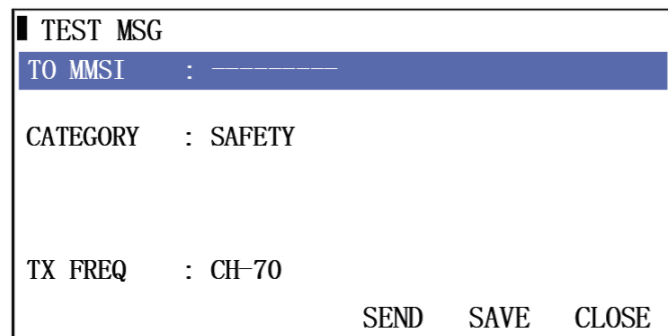

Figure5.6.1

◇ **Receiving a Test Acknowledgment Call**

When the device receives a test acknowledgment call, it will emit a prompt sound and display the information contained in the acknowledgment call, as shown in Figure 5.6.2.

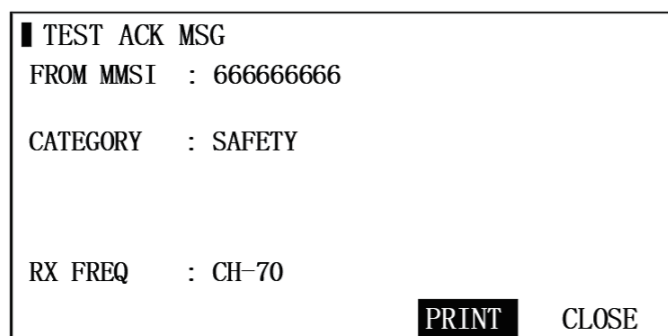

Figure5.6.2

Select the <PRINT> item and press the [ENT] key to print the call.
Select the <CLOSE> item and press the [ENT] key to close the interface and return to the main interface.

◇ **Receiving a Test Call**

When the device receives a test call, it will emit a prompt sound and display the information contained in the call, as shown in Figure 5.6.3.

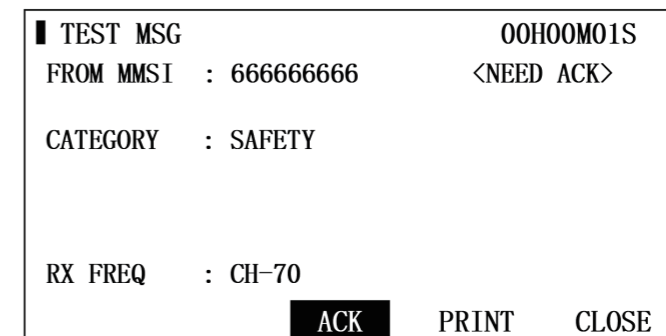

Figure5.6.3

Select the <ACK> item and press the [ENT] key to send a response call.
Select the <PRINT> item and press the [ENT] key to print the call.
Select the <CLOSE> item and press the [ENT] key to close the interface and return to the main interface.

◆ **Data Call**

Select the <DATA MSG> item from the call list. Refer to Section 5.1 of this manual for the operation of single station calls.

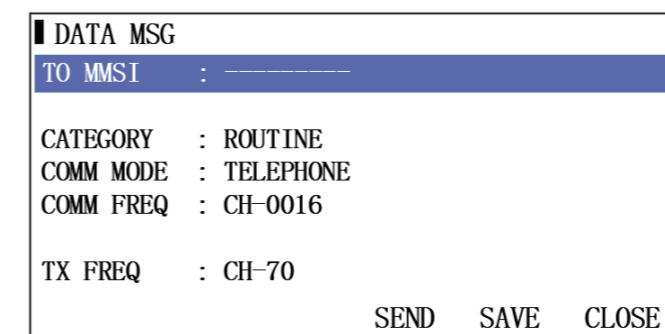

Figure5.7.1

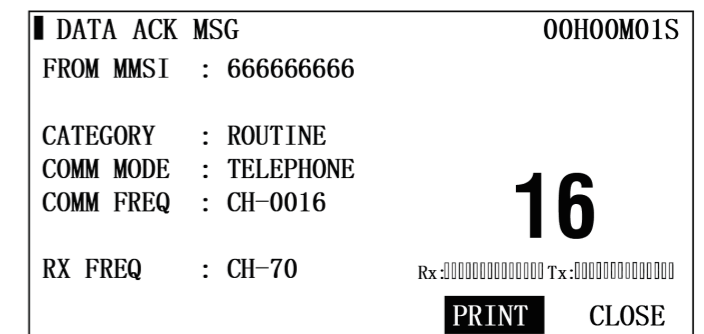

Figure5.7.2

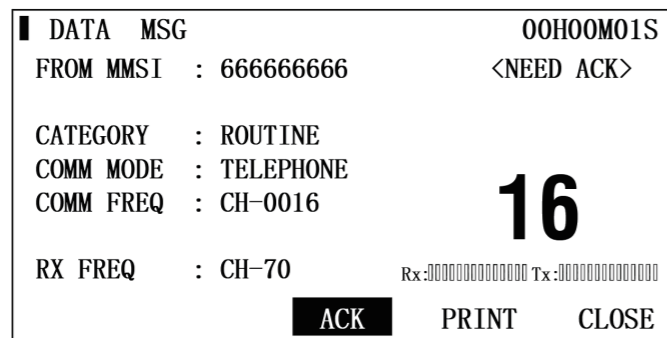

Figure5.7.3

◆ Neutral Ship Call

* Neutral ship calls can only be sent if the special call feature of the device is enabled. For details on enabling special calls, refer to the menu operation.

Select the <NEUTRAL> item from the call list. Refer to Section 5.2 of this manual for the operation of all stations calls.

Neutral ship calls can only be set to emergency call category.

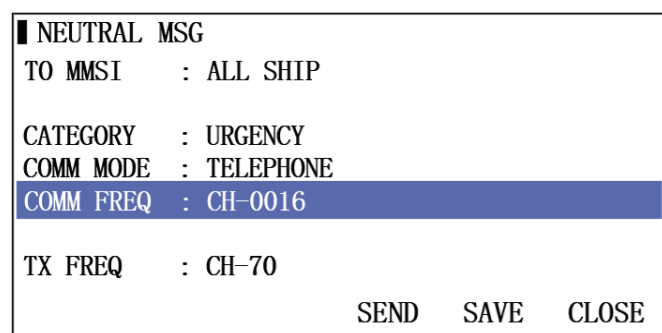

Figure5.8.1

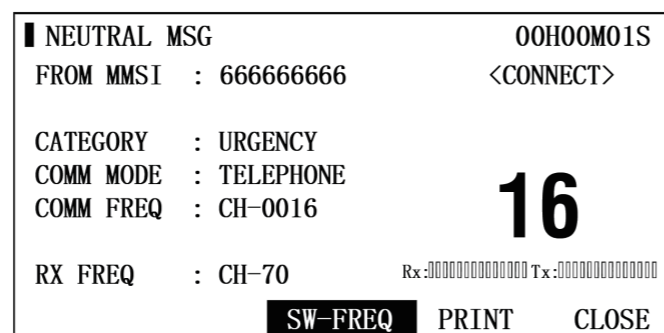

Figure5.8.2

◆ Medical Ship Call

* Medical ship calls can only be sent if the special call feature of the device is enabled. For details on enabling special calls, refer to the menu operation.

Select the <MEDICAL> item from the call list. Refer to Section 5.2 of this manual for the operation of all stations calls.

Medical ship calls can only be set to emergency call category.

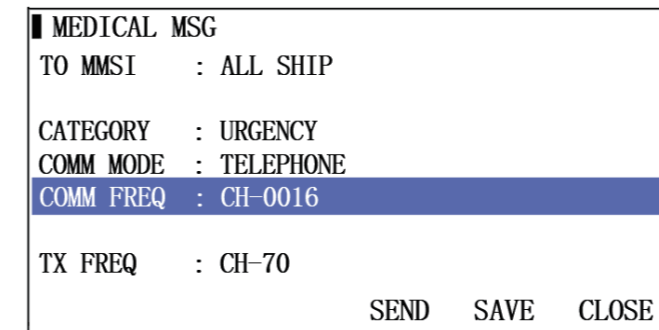

Figure5.9.1

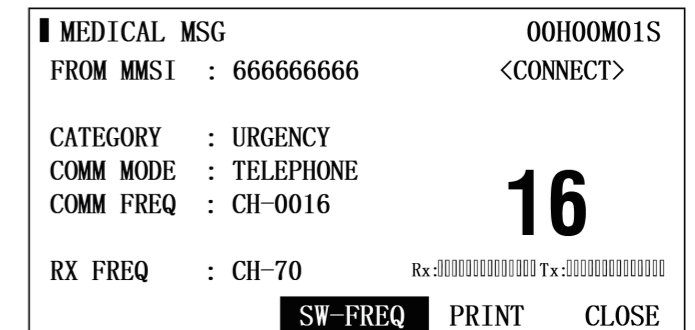

Figure5.9.2

◆ Query Call

* The device only receives query calls.

When the device receives a query call, it will emit a prompt sound and display the information contained in the call, as shown in Figure 5.10.1.

Select the <ACK> item and press the [ENT] key to send a response call.

Select the <PRINT> item and press the [ENT] key to print the call.

Select the <CLOSE> item and press the [ENT] key to close the interface and return to the main interface.

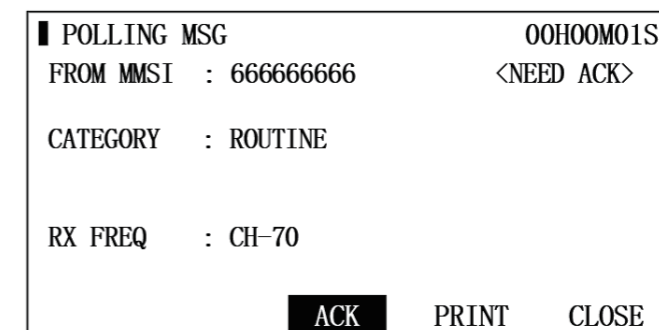

Figure5.10.1

Menu Operation

◆ How to Use the Menu

Press the [MENU] key on the panel to open the main menu. Rotate the [CHANNEL] knob to select the submenu or operation item you want to enter, then press the [ENT] key to confirm and enter the submenu.
Press the [CANCEL] key to return to the previous menu.

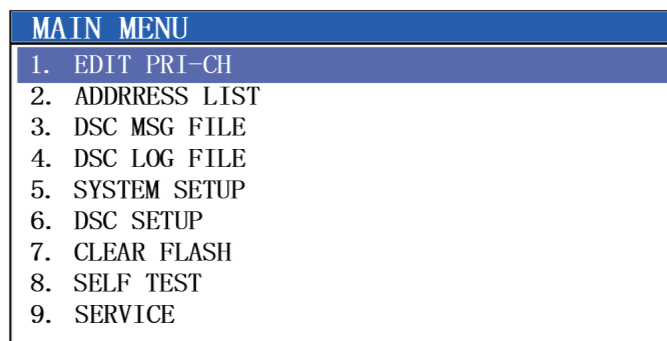

Figure6.1

◆ Editing User Channels

The device can use up to 200 user channels, which must be set with transmit and receive frequencies before use.
How to edit user channels:

- a: In the main menu, select the <EDIT PRI-CH> item and press the [ENT] key to open the channel information list.
- b: Select the channel number you want to edit, then press the [ENT] key to open the channel operation dialog, as shown in Figure 6.2.1. Select <EDIT SELECT CHANNEL> and press the [ENT] key to open the editing dialog.

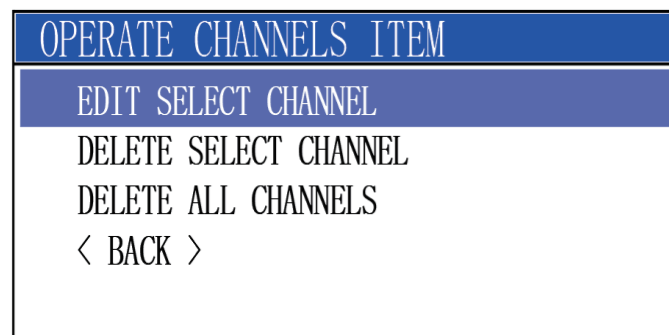

Figure6.2.1

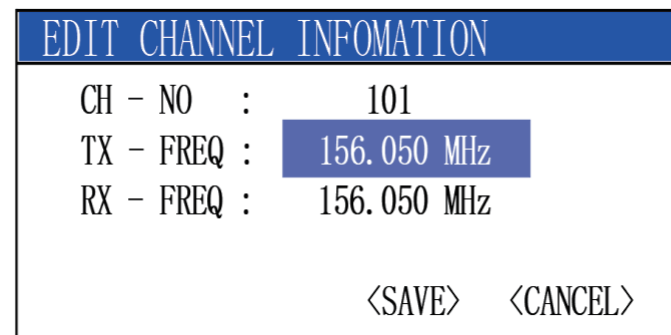

Figure6.2.2

c: Use the numeric keypad to enter the transmit and receive frequencies, then rotate the [CHANNEL] knob to select the <SAVE> item and press the [ENT] key to save.

How to delete user channels:

In the channel operation dialog opened in step b of this section, rotate the [CHANNEL] knob to select the <DELETE SELECT CHANNEL> item or the <DELETE ALL CHANNELS> item, then press the [ENT] key to delete the corresponding channel.

* The transmit/receive frequencies of user channels must be within the maritime frequency range and divisible by 25 kHz.

◆ Address Book

The device allows the operator to store 20 ship MMSI numbers, 20 shore station MMSI numbers, 20 group MMSI numbers, and 20 telephone numbers for easy input when sending calls.

How to add/edit an entry:

- a: In the main menu, select the <ADDRESS LIST> item and press the [ENT] key to open the address book list. Select the type of entry you want to edit and press the [ENT] key to open the address book list.
- b: Rotate the [CHANNEL] knob to select the entry you want to edit, and press the [ENT] key to open the entry operation dialog, as shown in Figure 6.3.1.

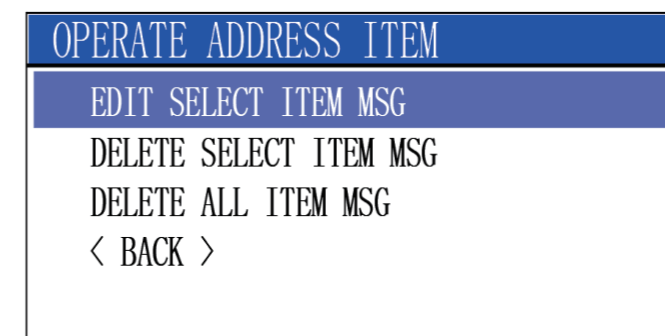

Figure6.3.1

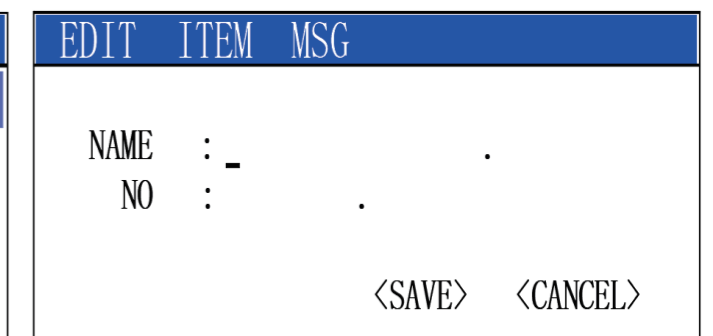

Figure6.3.2

c: Rotate the [CHANNEL] knob to select the <EDIT SELECT ITEM MSG> item, and press the [ENT] key to open the edit entry information dialog. Use the numeric keypad to enter the name and number of the entry.

d: After entering the information, rotate the [CHANNEL] knob to the <SAVE> item and press the [ENT] key to confirm and save.

How to delete an entry:

In the entry operation dialog opened in step b of this section, rotate the [CHANNEL] knob to select the <DELETE SELECT ITEM MSG> item or the <DELETE ALL ITEM MSG> item, and press the [ENT] key to delete the corresponding entry.

◆ Call Files

The device can save 100 pre-edited general calls.

- a:Select the <Call File> item in the main menu,and press the [ENT] key to open the call file list.
- b:Rotate the [CHANNEL] knob (you can also use the [3] and [9] number keys to ture pages)to select the call to operate,and press the [ENT] key to open the operation dialog box,as shown in Figure 6.4

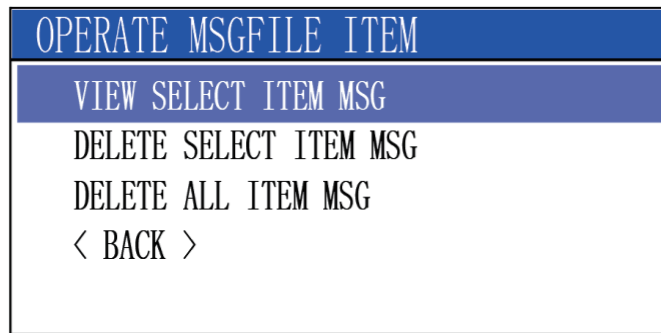

Figure6.4

- c:Rotate the channel knob to select the operation to perform(view,delete).
- d:Press the [CE] key to exit the file list.

◆ Call Log

The device can save transmitted and distress calls,and general calss,with each type able to store up to 100 entries.

- a:Select the <Call Log> item in the main menu,and press the [ENT] key to open the call log list.

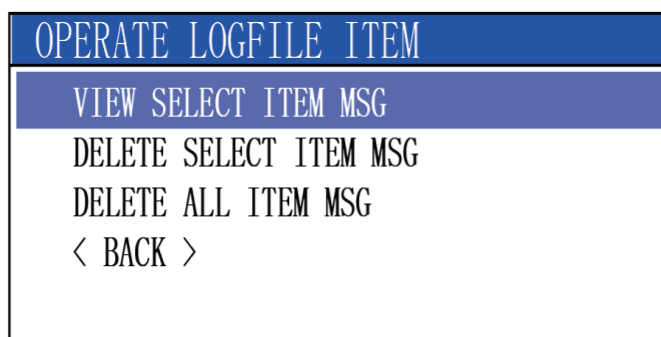

Figure6.5

- b:Rotate the [CHANNEL] knob to select the call type to view,and press the [ENT] key to open the correspond- ing call log file list.
- c:Rotate the [CHANNEL] knob(you can also use [3] and [9] number keys to ture pages) to select the call to operate,and press the [ENT] key to open the call log operation dialog box,as shown in Figure 6.5.2.
- d:Rotate the channel knob to select the operation to perform(view,delete).
- e:Press the [CE] key to exit the file list.

◆ System Settings

◇ Local Time Setup

The device has an internal RTC (Real-Time Clock) module that can generate local date and time.

How to set the internal RTC:

- a:In the system settings menu, select the <RTC TIME SETUP> item and press the [ENT] key to open the local time setup dialog, as shown in Figure 6.6.1.
- b: Use the numeric keypad to enter the date and time information. You can also rotate the [CHANNEL] knob to control the cursor position and change the number at that position. After entering the information, select the <SAVE> item and press the [ENT] key to save the time information.

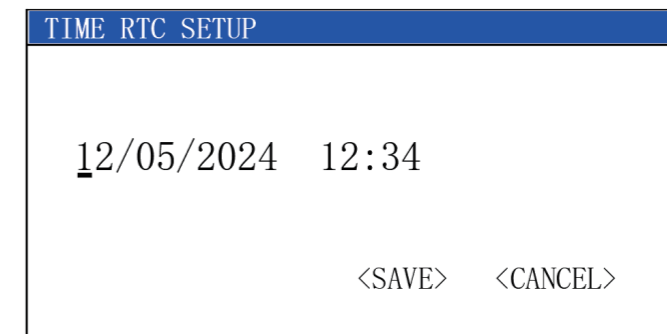

Figure6.6.1

◇ Time Difference Setting

When the device receives vaild GNSS date,it can calculate the local time based on UTC time and display it on the main interface. The calculate formula is $RTC=UTC + \text{time difference}$.

How to set the time difference:

- a:Select the <Time Difference Setting> item in the system setting menu,and press the [ENT] key to open the time time difference,as shown in Figure 6.6.2.
- b:Press the [ENT] key to open the time difference list,which can range from-12 hours to + 12hours.
- c:Rotate the channel knob to set the desired time difference,and press the [ENT] key to confirm.
- d:Press the [CE] key to reture to the system setting menu.

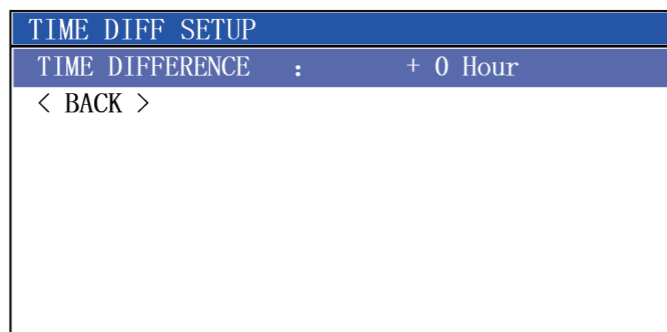

Figure6.6.2

◇ Timeout Setting

When the operate presses the PPT button for longer than the set time, the device will automatically ture off the transmission.How to set the timeout duration:

- a:Select the <Timeout Setting> item in the system setting menu,and press the [ENT] key to open the timeout setting dialog box,as shown in Figure 6.6.3.
- b:Press the [ENT] key to open the timeout duration list,which includes options for 1 minute,3 minutes,5 minutes and unlimited.
- c:Rotate the channel knob to select the desired timeout duration,and press the [ENT] key to confirm.
- d:Press the [ENT] key to reture to the system setting menu.

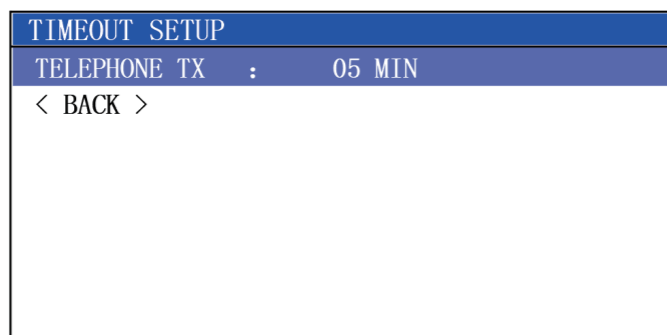

Figure6.6.3

◇ Speaker Setting

The device has a built-in speaker on the front panel and also supports external speaker,allowing users to choose according to their needs.

- a:In the system setting menu,select the <speaker setting> option and press the [ENT] key to open the speaker settings dialog box,an shown in Figure 6.6.4
- b:Press the [ENT] key to open the speaker type list,where you can choose between internal or external speaker.
- c:Rotate the channel knob to select the type of speaker to be set,and press the [ENT] key to confirm.
- d:Press the [CE] key to reture to the system setting menu.

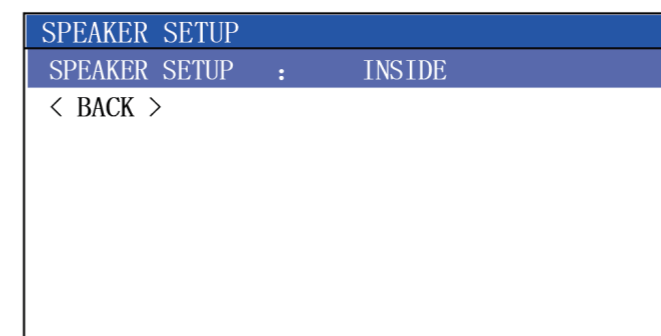

Figure6.6.4

◇ Language Settings

The device supports both Chinese and English displays.

- a:In the system settings menu,select the <Language Settings> option and press the [ENT] key to open the language seelction dialog box,as shown in Figure 6.6.5.
 - b:Press the [ENT] key to open the language type list,where you can choose between Chinese or English.
 - c:Rotate the channel knob to select the language to be set,and press the [ENT] key to confirm.
- Reture to the main interface.



Figure6.6.5

◇ **Sound Settings**

The device allows users to disable key sounds and error operation prompts.

a: In the system settings menu, select the **<Sound settings>** option and press the **[ENT]** key to open the sound settings dialog box, as shown in Figure 6.6.6.

b: Rotate the channel knob to select the type of sound to be set, and press the **[ENT]** key to open the status list, where you can choose to enable or disable.

c: Rotate the channel knob to select the status, and press the **[ENT]** key to confirm.

d: Press the **[CE]** key to return to the system settings menu.

AUDIO SETUP	
BEEP SOUND	: ON
ERROR SOUND	: ON
< BACK >	

Figure6.6.6

◇ **Communication Rate Settings**

a: In the system settings menu, select the **<Communication Rate Settings>** option and press the **[ENT]** key to open the Communication Rate Settings dialog box, as shown in Figure 6.6.7.

b: Rotate the channel knob to select the rate to be set, and press the **[ENT]** key to open the rate list, where you can choose 4800bps, 9600bps, 19200bps, 38400bps, or 115200bps.

c: Rotate the channel knob to select the rate, and press the **[ENT]** key to confirm.

d: Press the **[CE]** key to return to the system settings menu.

* When connecting to GNSS, be sure to select the corresponding rate. Generally, the input rate for GPS is 4800bps, and the input rate for Beidou is 9600bps.

COMM RATE RATE	
GNSS RATE	: 4800bps
RS-232 RATE	: 115200bps
RS-422 RATE	: 9600bps
< BACK >	

Figure6.6.7

◇ **Display Mode Settings**

a: In the system settings menu, select the **<Display Mode Settings>** option and press the **[ENT]** key to open the display mode settings dialog box, as shown in Figure 6.6.8.

b: Rotate the channel knob to select the mode to be set, and press the **[ENT]** key to open the display mode list, where you can choose between Bright and Dark modes.

c: Rotate the channel knob to select the mode to be set, and press the **[ENT]** key to confirm.

d: Press the **[CE]** key to return to the system settings menu.

DISP MODE SETUP	
MAIN BACK MODE	: LIGHT
OTHER BACK MODE	: LIGHT
< BACK >	

Figure6.6.8

◇ **Recording Settings**

a: In the system settings menu, select the "Recording Settings" option and press the **[ENT]** key to open the recording settings dialog box, as shown in Figure 6.6.9

b: Press the **[ENT]** key to open the recording time list, where you can choose between 1 to 7 days.

c: Rotate the channel knob to select the desired time and press the **[ENT]** key to confirm.

d: Press the **[CE]** key to return to the system settings menu.

RECORD SETUP	
WAV SAVE TIME	: 06 DAY
< BACK >	

Figure6.6.9

◆ Digital Selective Calling (DSC) Settings

◇ Local MMSI Setup

The device allows the user to change the local MMSI number up to 3 times. After 3 changes, a password is required to continue changing the MMSI number.

a: In the DSC settings menu, select the **<MMSI SETUP>** item and press the **[ENT]** key to open the local MMSI number setup dialog, as shown in Figure 6.7.1.

b: Use the numeric keypad to enter the MMSI number information. Rotate the **[CHANNEL]** knob to control the cursor position and change the number at that position. After entering the information, select the **<SAVE>** item to save the time information.

c: Press the **[ENT]** key to return to the DSC settings menu.

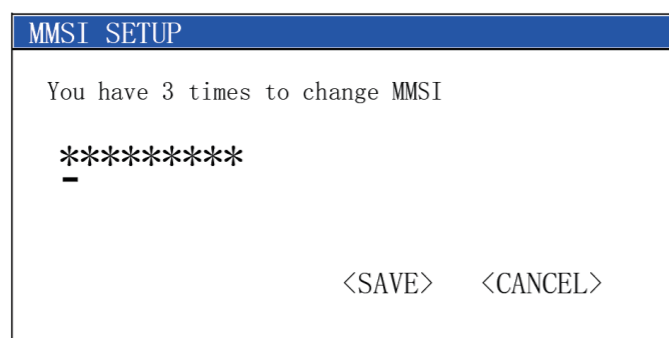

Figure6.7.1

◇ Position Setup

When the device does not have an external GNSS, it allows the user to manually input GNSS information.

a: In the DSC settings menu, select the **<POSITION SETUP>** item and press the **[ENT]** key to open the GNSS information setup dialog, as shown in Figure 6.7.2.

b: Use the numeric keypad to enter the GNSS information. Rotate the **[CHANNEL]** knob to control the cursor position and change the number at that position. After entering the information, select the **<SAVE>** item to save the time information.

c: Press the **[ENT]** key to return to the DSC settings menu.

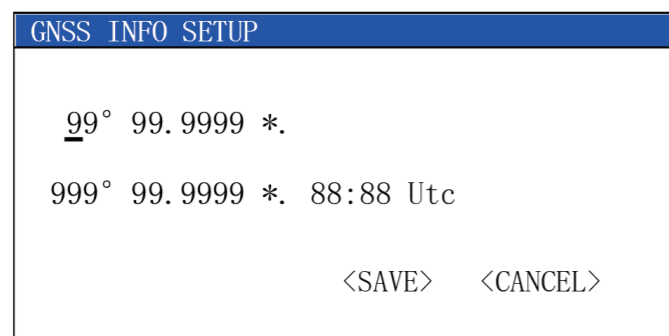

Figure6.7.2

◇ Acknowledgment Settings

The device allows the user to set the acknowledgment mode for calls. By default, all calls are set to manual acknowledgment.

a: In the DSC settings menu, select the **<ACK SETUP>** item and press the **[ENT]** key to open the acknowledgment settings dialog, as shown in Figure 6.7.3.

b: Rotate the **[CHANNEL]** knob to select the type of call you want to set, and press the **[ENT]** key to open the acknowledgment mode list, where you can choose between manual response and automatic response, among other options.

c: Rotate the **[CHANNEL]** knob to select the acknowledgment mode, and press the **[ENT]** key to confirm.

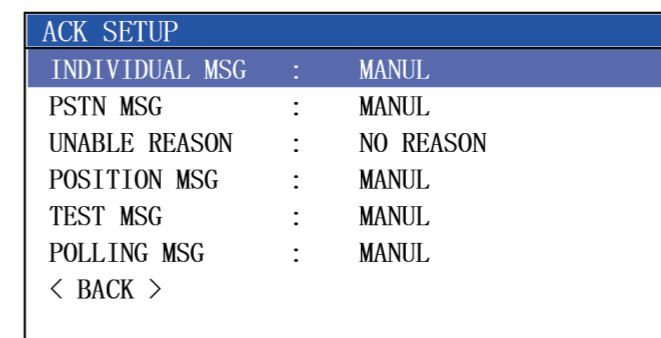

Figure6.7.3

d: Press the **[CE]** key to return to the DSC settings menu.

* The UNABLE reason is required when the acknowledgment mode is set to automatic acknowledgment (UNABLE) mode.

◇ Print Settings

The device supports connection to a serial printer (specific model required, please consult the supplier). It can print call information when sending or receiving calls. The device can be set to either automatic or manual print mode, with the default being manual print mode.

a: In the DSC settings menu, select the **<PRINT SETUP>** item and press the **[ENT]** key to open the print settings dialog, as shown in Figure 6.7.4.

b: Rotate the **[CHANNEL]** knob to select the type of call to be set, and press the **[ENT]** key to open the status list, where you can choose between manual printing and automatic printing.

PRINT SETUP		
TX DISTRESS MSG	:	MANUL
TX GENERAL MSG	:	MANUL
RX DISTRESS MSG	:	MANUL
RX GENERAL MSG	:	MANUL
< BACK >		

Figure6.7.4

c: Rotate the [CHANNEL] knob to select the print mode to be set, and press the [ENT] key to confirm.

d: Press the [CE] key to return to the DSC settings menu.

*The printer must be connected to the RS-232 interface, and the communication speed of the RS-232 must be match that of the printer .

◆ Frequency Switching Settings

When the device receives a general call, it allows the user to set the communication channel switching mode, which can be either automatic or manual. The default is manual switching.

a: In the DSC settings menu, select the <SWITCH SETUP> item and press the [ENT] key to open the frequency switching settings dialog, as shown in Figure 6.7.5.

b: Rotate the [CHANNEL] knob to select the desired call level. Ppress the [ENT] key to open the conversion mode list,where you can choose between manual or automatic.

c: Rotate the [CHANNEL] knob to select the switching mode, and press the [ENT] key to confirm.

d: Press the [CE] key to return to the DSC settings menu.

SWITCH SETUP		
ROUTINE	:	AUTO
SAFETY	:	AUTO
URGENCY	:	AUTO
< BACK >		

Figure6.7.5

◆ Special Call Settings

Special calls include neutral ship calls and medical ship calls. By default, special calls are disabled, but users can enable them in this menu item.

a: In the DSC settings menu, select the <SPECIAL SETUP> item and press the [ENT] key to open the special call settings dialog, as shown in Figure 6.7.6.

b: Rotate the [CHANNEL] knob to select the desired call type. Press the [ENT] key to open the special call status list, where you can choose to disable or enable.

c: Rotate the [CHANNEL] knob to select the enable status for the special call, and press the [ENT] key to confirm;

d: Press the [CE] key to return to the DSC settings menu.

SPECIAL CALL SETUP		
NEUTRAL CALL	:	UNABLE
MEDICAL CALL	:	UNABLE
< BACK >		

Figure6.7.6

◆ Clearing Memory

When the device settings are incorrect or various information needs to be cleared, this function can be used. Selecting <CLEAR FLASH> in the main menu will clear all user-set information, including menu item settings, user channel frequencies, and address book information.

a: In the main menu, select the <CLEAR FLASH> item and press the [ENT] key to open the factory reset dialog.

b: Rotate the [CHANNEL] knob to select the <Confirm> item and press the [ENT] key to clear all user information from the memory.

c: Press the [CE] key to return to the main menu.

◆ Self-Test

The device has a self-test function to check whether the reception, transmission, DSC, and memory are working correctly.

a: In the main menu, select the <SELF TEST> item and press the [ENT] key to open the self-test dialog.

The device will start the self-test.

b: After the self-test is completed, press the [ENT] key or the [CE] key to return to the main menu.

◆ Service Information

Displays the device's serial number, current hardware version information, software version information, and manufacturing date.

a: In the main menu, select the <SERVICE> item and press the [ENT] key to open the service information dialog.

b: Press the [CE] key to return to the main menu.

GNSS Device Connection

The GNSS interface of the FT-1100 can connect to GNSS receivers with RS232 or RS422 output. The communication rate is selectable, see menu operation for details. The GNSS data format received by the FT-1100 is NMEA0183 version 2.0, including RMC, GGA, GLL, ZDA, and GNS sentences. When the device is correctly connected to the GNSS device and receives valid GNSS information, the screen displays “-- AUTO INPUT --”. If the connection between the device and the GNSS device is interrupted for 30 seconds, the device will save the last received GPS information, and the screen will display “--Lost - 30s --”. If the GNSS information is not updated within 4 hours, the device screen will display “-- Lost - 4hour --” and a warning prompt will appear, as shown in Figure 7.1. Press the [CE] key to close the warning prompt. If the GNSS information is not updated within 23.5 hours, the device screen will display “--Lost - 23.5h-our --” and a warning prompt will appear, as shown in Figure 7.2. At the same time, the GNSS information of the device will be set to the default invalid information. Press the [CE] key to close the warning prompt.

* The invalid GNSS information is represented by all 9s for latitude and longitude, and all 8s for UTC time.

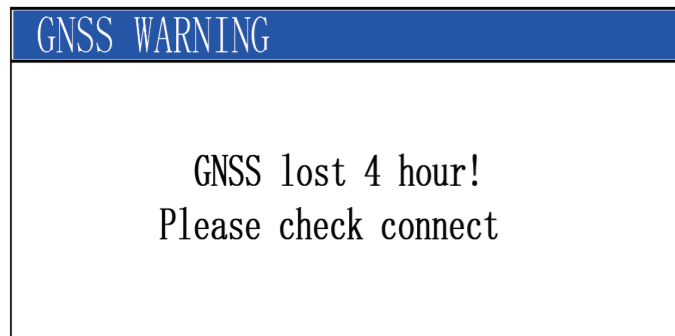

Figure7.1

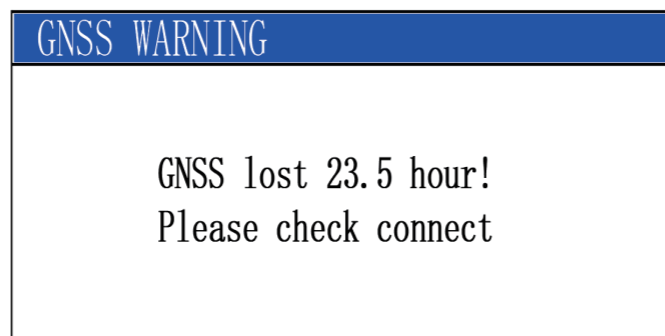
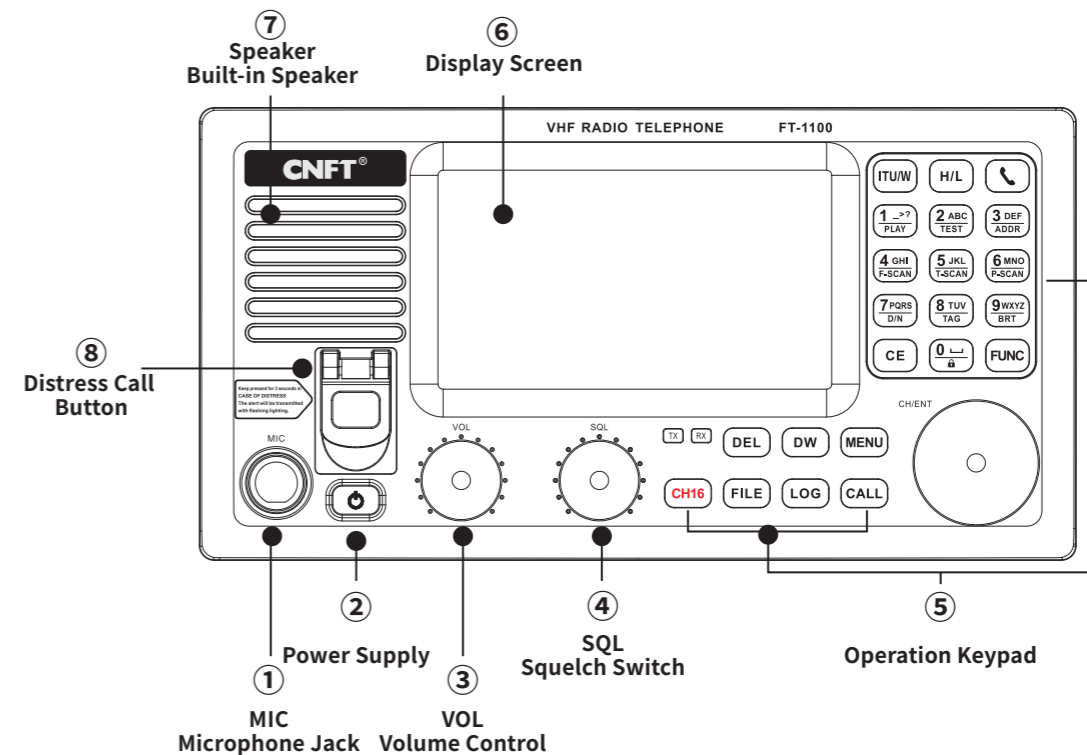

Figure7.2

Interface Specification

Front View



Rear View

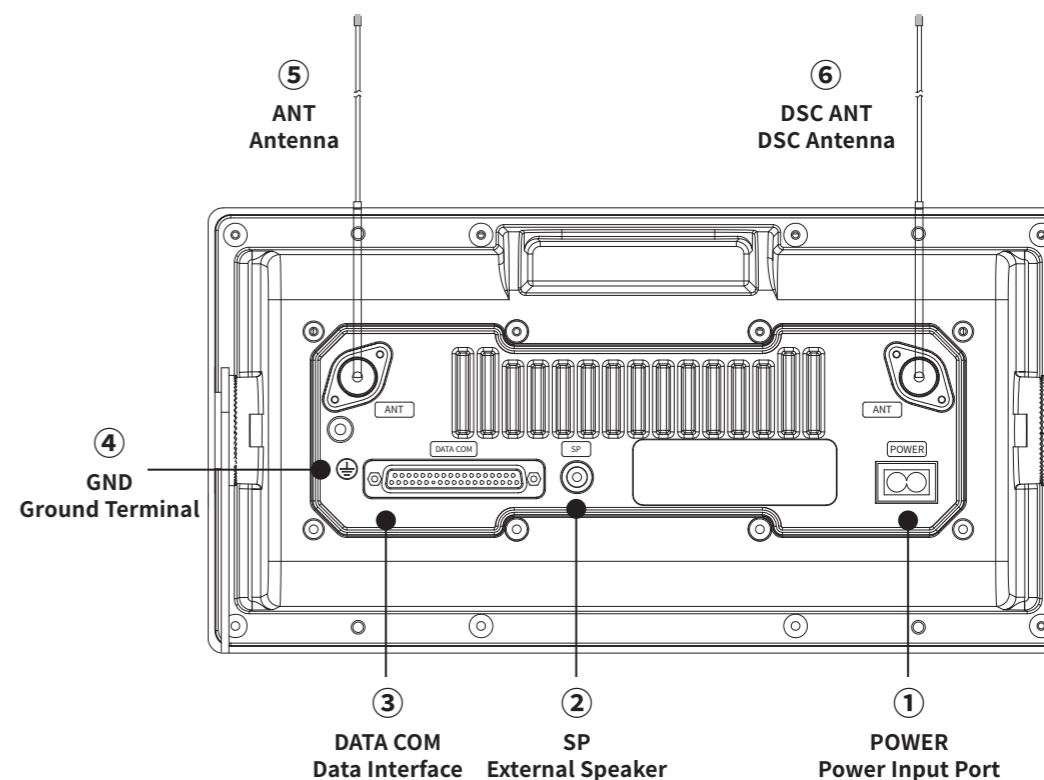

■ Port Descriptions

①POWER – Power Input Port

※Note: 12V (10.8V–15.6V) DC, 5A

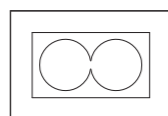

Red: Power Input Terminal (+)
Black: Power Input Terminal (-)

②3.5mm External Speaker Output Port

③ DATA COM – Data Interface

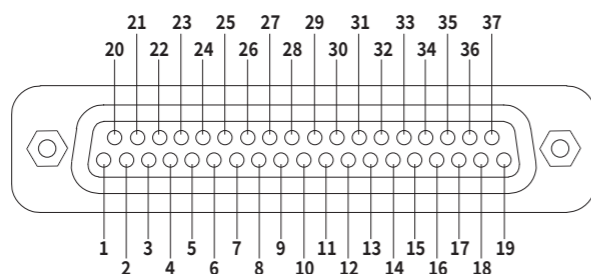

NO.	Definition	Function
1	GNSS+	Position Data Input +
2	GNSS-	Position Data Input -
3	3.3V	3.3V Power Output
4	GND	Internal Ground
5	RX232_RXD	RS-232 Receive (RX)
6	RX232_TXD	RS-232 Transmit (TX)
7	EXP_ALARM_L+	External Alarm Interface (Active Low)
8	EXP_ALARM_L-	External Alarm Interface (Active Low)
9	RS422_RXD+	RS-422 Receive +
10	RS422_RXD-	RS-422 Receive -
11	RS422_TXD-	RS-422 Receive -
12	RS422_TXD+	RS-422 Receive -
13	EXP_ALARM_H+	External Alarm Interface (Active High)

NO.	Definition	Function
14	EXP_ALARM_H-	External Alarm Interface (Active High)
15	CAN_H	External Handset Communication Interface
16	CAN_L	External Handset Communication Interface
17	EXP_SP+	External Handset Communication Interface
18	EXP_MIC1	External Handset Audio Output
19	EXP_MIC4	External Handset Audio Output
20	GND	Internal Ground
21	VDR+	VDR Device Interface
22	VDR+	VDR Device Interface
23	VDR-	VDR Device Interface
24	VDR-	VDR Device Interface
25	RELAY2	External Handset Control 2
26	DIO	Control Firmware Update Interface
27	CLK	Control Firmware Update Interface
28	RST	Control Firmware Update Interface
29	RELAY3	External Handset Control 3
30	USB_DM	Operation Firmware Update Interface
31	USB_DP	Operation Firmware Update Interface
32	B00T0	Operation Firmware Update Interface
33	B00T1	Operation Firmware Update Interface
34	GND	Internal Ground
35	GND	Internal Ground
36	13.8V	13.8V Output
37	13.8V	13.8V Output

④ GND (System Grounding Port)

⑤ ANT (RX/TX Antenna for Receiving and Transmitting)

⑥ DSC ANT (DSC Watch Antenna Interface)

Appendix

◆ Appendix A: USA Frequency Bands Table (USA)

Channel	Frequency (MHz)		Channel	Frequency (MHz)	
	Transmission	Reception		Transmission	Reception
1001	156.050	156.050	60		
2			61		
3			62		
4			1063	156.175	156.175
1005	156.250	156.250	64		
6	156.300	156.300	1065	156.275	156.275
1007	156.350	156.350	1066	156.325	156.325
8	156.400	156.400	67 *L	156.375	156.375
9	156.450	156.450	68	156.425	156.425
10	156.500	156.500	69	156.475	156.475
11	156.550	156.550	70 *D	156.525	156.525
12	156.600	156.600	71 *L	156.575	156.575
13 *L	156.650	156.650	72	156.625	156.625
14	156.700	156.700	73	156.675	156.675
15	*RX only	156.750	74	156.725	156.725
16	156.800	156.800	75		
17 *L	156.850	156.850	76		
1018	156.900	156.900	77 *L	156.875	156.875
1019	156.950	156.950	1078	156.925	156.925
20	157.000	161.600	1079	156.975	156.975
1020	157.000	157.000	1080	157.025	157.025
1021	157.050	157.050	1081	157.075	157.075
1022	157.100	157.100	1082	157.125	157.125
1023	157.150	157.150	1083	157.175	157.175
24	157.200	161.800	84	157.225	161.825
25	157.250	161.850	85	157.275	161.875
26	157.300	161.900	86	157.325	161.925
27	157.350	161.950	87	157.375	157.375
28	157.400	162.000	88	157.425	157.425

*L: Low Power Only * D: DSC Band *RXonly: TX Prohibited

◆ Appendix B: International Frequency Bands Table (INT)

Channel	Frequency (MHz)		Channel	Frequency (MHz)	
	Transmission	Reception		Transmission	Reception
1	156.050	160.650	60	156.025	160.625
2	156.100	160.700	61	156.075	160.675
3	156.150	160.750	62	156.125	160.725
4	156.200	160.800	63	156.175	160.775
5	156.250	160.850	64	156.225	160.825
6	156.300	156.300	65	156.275	160.875
7	156.350	160.950	66	156.325	160.925
8	156.400	156.400	67	156.375	156.375
9	156.450	156.450	68	156.425	156.425
10	156.500	156.500	69	156.475	156.475
11	156.550	156.550	70 *D	156.525	156.525
12	156.600	156.600	71	156.575	156.575
13	156.650	156.650	72	156.625	156.625
14	156.700	156.700	73	156.675	156.675
15 *L	156.750	156.750	74	156.725	156.725
16	156.800	156.800	75 *L	156.775	156.775
17 *L	156.850	156.850	76 *L	156.825	156.825
18	156.900	161.500	77	156.875	156.875
19	156.950	161.550	78	156.925	161.525
1019	156.950	156.950	1078	156.925	156.925
2019	*RX only	161.550	2078	*RX only	161.525
20	157.000	161.600	79	156.975	161.575
1020	157.000	157.000	1079	156.975	156.975
2020	*RX only	161.600	2079	RX only	161.575
21	157.050	161.650	80	157.025	161.625
22	157.100	161.700	81	157.075	161.675
23	157.150	161.750	82	157.125	161.725
24	157.200	161.800	83	157.175	161.775
25	157.250	161.850	84	157.225	161.825
26	157.300	161.900	85	157.275	161.875
			86	157.325	161.925
1027	157.350	157.350	87	157.375	157.375
1028	157.400	157.400	88	157.425	157.425

*L: Low Power Only * D: DSC Band *RXonly: TX Prohibited

◆ Appendix C: Canada Frequency Bands Table (CAN)

Channel	Frequency (MHz)		Channel	Frequency (MHz)	
	Transmission	Reception		Transmission	Reception
1001	156.050	156.050	60		
2			61		
3			62		
4			1063	156.175	156.175
1005	156.250	156.250	64		
6	156.300	156.300	1065	156.275	156.275
1007	156.350	156.350	1066	156.325	156.325
8	156.400	156.400	67 *L	156.375	156.375
9	156.450	156.450	68	156.425	156.425
10	156.500	156.500	69	156.475	156.475
11	156.550	156.550	70 *D	156.525	156.525
12	156.600	156.600	71 *L	156.575	156.575
13 *L	156.650	156.650	72	156.625	156.625
14	156.700	156.700	73	156.675	156.675
15	*RX only	156.750	74	156.725	156.725
16	156.800	156.800	75		
17 *L	156.850	156.850	76		
1018	156.900	156.900	77 *L	156.875	156.875
1019	156.950	156.950	1078	156.925	156.925
20	157.000	161.600	1079	156.975	156.975
1020	157.000	157.000	1080	157.025	157.025
1021	157.050	157.050	1081	157.075	157.075
1022	157.100	157.100	1082	157.125	157.125
1023	157.150	157.150	1083	157.175	157.175
24	157.200	161.800	84	157.225	161.825
25	157.250	161.850	85	157.275	161.875
26	157.300	161.900	86	157.325	161.925
27	157.350	161.950	87	157.375	157.375
28	157.400	162.000	88	157.425	

*L: Low Power Only * D: DSC Band *RXonly: TX Prohibited *CH20xx is equivalent to CHxxB

◆ Appendix D: Weather Frequency Bands Table (WX)

Channel	Frequency (MHz)	
	Transmission	Reception
01	*RX only	162.550
02	*RX only	162.400
03	*RX only	162.475
04	*RX only	162.425
05	*RX only	162.450
06	*RX only	162.500
07	*RX only	162.525
08	*RX only	161.650
09	*RX only	161.775
10	*RX only	163.275
11	*RX only	149.225
12	*RX only	149.850
13	*RX only	160.650

*RXonly: TX Prohibited

Maintenance

Phenomenon	Potential Cause	Corrective Action
Cannot Power On	Power leads reversed; power cord not fully inserted; input voltage over-range	Check and correct power wiring polarity; fully insert power cord; ensure input voltage is within the specified range
Insufficient Transmit Power	Improper antenna installation (loose or misaligned); nearby obstructions	Reinstall antenna securely at the correct angle; remove any nearby obstructions
Weak or No Receive Signal	Antenna improperly connected; antenna entangled with foreign objects	Verify and reconnect the antenna; clear any debris or tangles around the antenna
Excessive Channel Noise	Unit not grounded; interference from nearby electrical equipment	Properly ground the unit; relocate it away from noise-generating devices

◆ Periodic Inspection

Please perform the following checks regularly to maintain optimal performance.

Item	Issue	Action
Power Cable	Exposed or damaged	Replace
Power Plug	Loose	Secure
Display Panel	Corroded	Clean
Supply Voltage	Over-voltage or under-voltage	Check power system

◆ Cleaning

Dust and stains on the instrument's surface can be wiped away with a soft cloth. If necessary, a dampened soft cloth may be used. Exercise extra care when cleaning the LCD, as it is easily scratched.

Do not use chemical cleaners, as they may remove paint or markings from the instrument's surface.

安全提示

⚠ 危险!

- 若有物品掉入设备或水溅入设备, 立即关闭配电板电源。(继续使用可能引发火灾或触电)
- 若设备冒烟或起火, 立即关闭配电板电源。(继续使用可能引发火灾或触电)
- 若设备运行异常, 立即关闭配电板电源。(继续使用可能引发火灾或触电, 建议联系代理商/经销商咨询)

⚠ 警告!

- 开始安装前, 务必关闭配电板电源。(安装过程中通电可能引发火灾或触电)
- 仅使用指定电源线。(使用其他电缆可能引发火灾或触电)
- 请勿在设备可能被雨水或溅水打湿的位置安装。(水进入设备内部可能引发火灾或触电)
- 请勿将盛有液体的容器放置在设备顶部。(可能引发火灾或触电)
- 请勿用湿手操作设备。(可能引发触电)
- 请勿拆卸或改装设备。(可能引发触电、火灾或人身伤害)

⚠ 警告!

- 除非完全熟悉电气电路, 否则请勿在设备内部作业。
- 设备内部存在可能导致触电的危险电压。

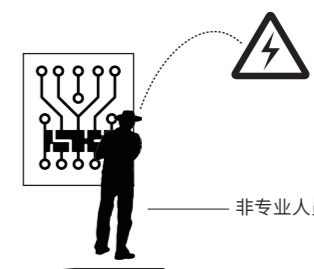

- 开始安装前, 请关闭主配电板上的电源。在开关附近张贴标志, 表明设备安装期间不应打开电源。如果设备安装期间电源未关闭或接通, 可能会导致火灾、触电或重伤。



- 除非船舶真正遇险, 否则请勿操作遇险按钮。(操作遇险按钮会发送遇险信号; 若意外发送, 需立即联系海岸电台报告)

⚠ 注意!

- 确认电源电压与设备的额定电压兼容。连接错误的电源可能会导致火灾或设备损坏。额定电压显示在显示单元背面的标签上。
- 小心使用接地铜带其边缘可能会伤到您的手。
- 请保持以下罗盘安全距离60MM以上。
- 接地设备: 未接地的设备可能会发出或收电磁干扰, 或导致触电。



目录

- 安全提示.....52
- 前言.....54
- 主要技术指标.....54
- 安装说明.....55-60
- 面板说明.....61-63
- 基本操作.....64-65
 - 如何开机.....64
 - 如何转换频道.....64
 - 如何进行无线电发射和接收.....64
 - 如何进行双看守.....64
 - 如何播放录音.....64
 - 如何快速发送DSC测试呼叫.....64
 - 如何进行全频道扫描.....64
 - 如何进行标记扫描.....65
 - 如何进行优先扫描.....65
 - 如何切换显示模式.....65
 - 如何标记/记忆当前频道.....65
 - 如何调节屏幕背光和按键背光亮度.....65
- 遇险报警呼叫操作.....66-69
 - 遇险报警呼叫.....66
 - 遇险报警转发呼叫.....68
- 普通呼叫操作.....70-80
 - 单台呼叫.....70
 - 所有台呼叫.....72
 - 群组呼叫.....73
 - 电话呼叫.....74
 - 位置请求呼叫.....76
 - 测试呼叫.....77
 - 数据呼叫.....79
 - 中立船呼叫.....79
 - 医疗船呼叫.....80
 - 查询呼叫.....80
- 菜单操作.....81-92
 - 如何使用菜单.....81
 - 编辑用户频道.....81
 - 通讯录.....82
 - 呼叫文件.....82
 - 呼叫日志.....83
 - 系统设置.....84
 - 数字选呼设置.....89
 - 清空存储器.....92
 - 自检测试.....92
 - 服务信息.....92
- GNSS 设备连接.....93
- 系统接口规格说明.....94-96
- 附录.....97-100
- 设备维护.....101

前言

感谢您选用本公司研制的产品,型号:FT-1100 名称:甚高频(A级DSC)无线电装置。产品包括主机以及随机配置附件,请参看产品《装箱清单表》。在安装使用产品前,请务必仔细阅读《产品使用说明书》,避免人员不专业、错误操作引起设备损坏或人身安全,本公司不承担由此引起的一切后果责任。

※注:若产品升级更新导致《产品使用说明书》与设备实际操作使用不一致,请以设备为准。

主要技术指标

项目名称	技术参数
电源	DC 24V +30/-10%
频道容量	57个国际海事频道并且扩展200个私有频道
频率宽带	25KHz
频率生成方法	频率合成
无线电接收机	采用双变换超外差设计,多频道接收 频率范围: 156.025Mhz-163.275Mhz IF用频率: 21.7MHz;450KHz;最大可用灵敏度: 0.5uV of 20dB/SINAD 邻频选择: ≥70dB;寄生信号干扰: ≥70dB 互调干扰: ≥68dB;寄生辐射: ≤2nW 电流: 0.9Amps(MaxAudio),0.4Amps (STBY) 音频频率响应: +1, -3dB of +6dB/octave (300-3000Hz) 噪声电平: ≤-40dB;信噪比: ≥40dB;阻塞: ≥90dB 音频输出: 2W(80hm,少于10%失真)
70频道DSC接收机	频率: CH70(156.525MHz);频率误差: ≤10Hz(1300Hz和2100Hz) 灵敏度: 1uV (在误码率小于1%的情况下) 带宽: 16KHz; IF用频率: 17.9MHz, 455KHz 邻频选择: ≥70dB;寄生信号干扰: ≥70dB 互调干扰: ≥65dB;接收模式: G2B;寄生辐射: ≤2nW, 9KHz to 2GHz
无线电发射机	调制类型: G3E(Voice), G2B(DSC);频率范围: 156.025Mhz-157.425Mhz 输出功率: 25W,1W (50 Ohms);音频谐波失真: ≤10% 音频频率响应: +1/-3dB of +6dB/octave, Pre-emphasis 300 - 3000Hz 剩余调制: ≤-40dB;频偏: ≤5KHz 最大峰值 寄生辐射: ≤0.25μW;电流: ≤5Amps(max)

安装说明

■ 电气安装

设备使用前,一定要正确的连接电源,天线以及需要连接的外部设备。
设备需要连接电压为24V,输出电流不小于5A的DC电源。

◇ 系统连接图说明

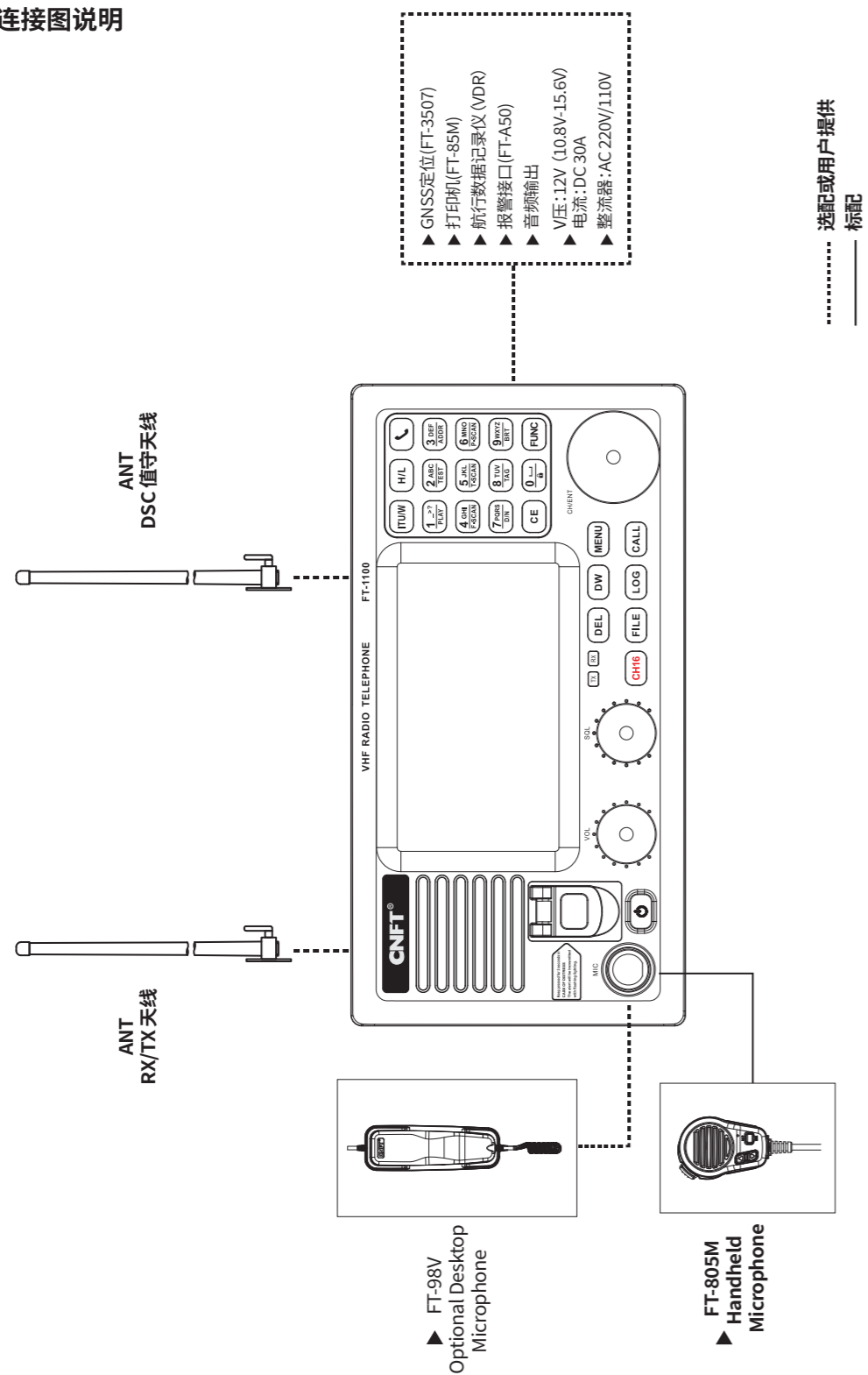

■ 固定安装

- * 产品应该安装在远离发动机并通风良好的地方。
- * 不要安装在阳光直射的地方。
- * 不要把产品放在距离罗经 1 米之内。

产品配有一个可以翻转的安装支架。支架用4枚螺丝固定。在安装之前,保证在支架后面有100mm的垂直空隙和70mm 的水平空隙,以便对产品进行调整。产品的倾斜角度可以通过夹钳进行调整。

显示单元支架类型

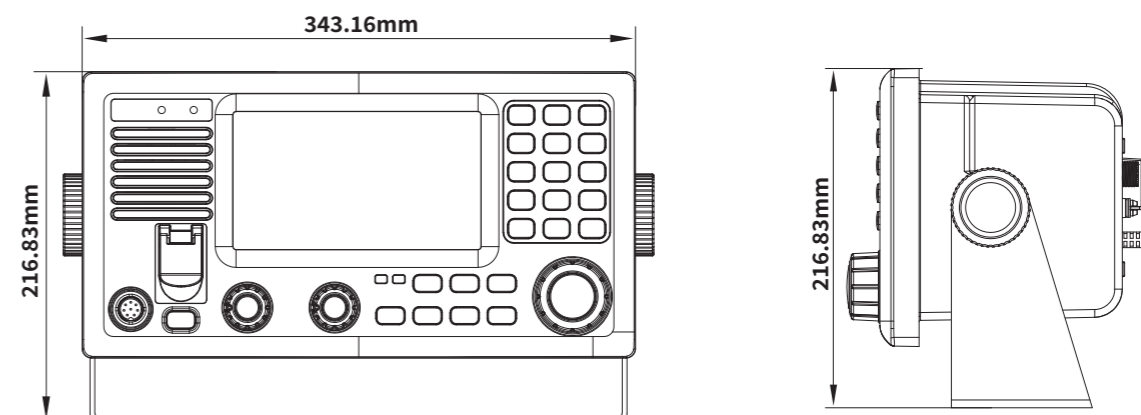

显示支架吊顶类型

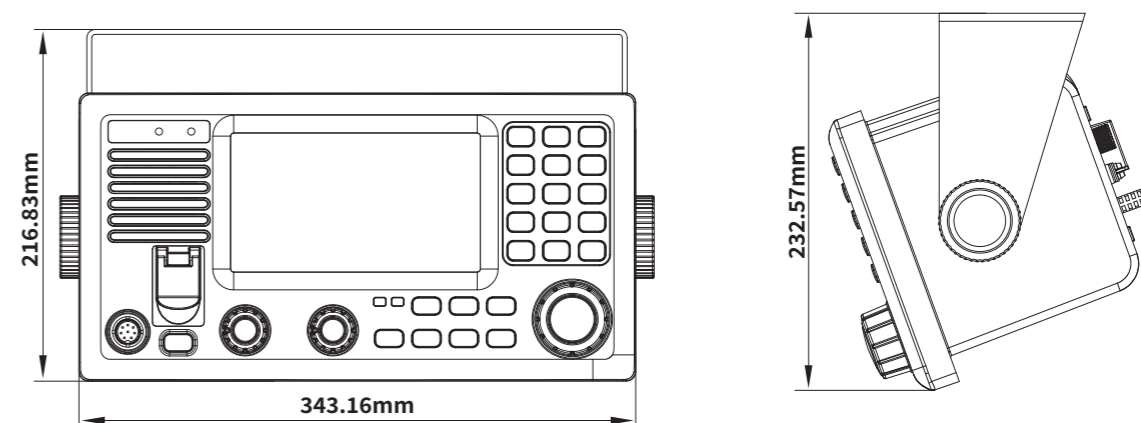

显示嵌入式类型

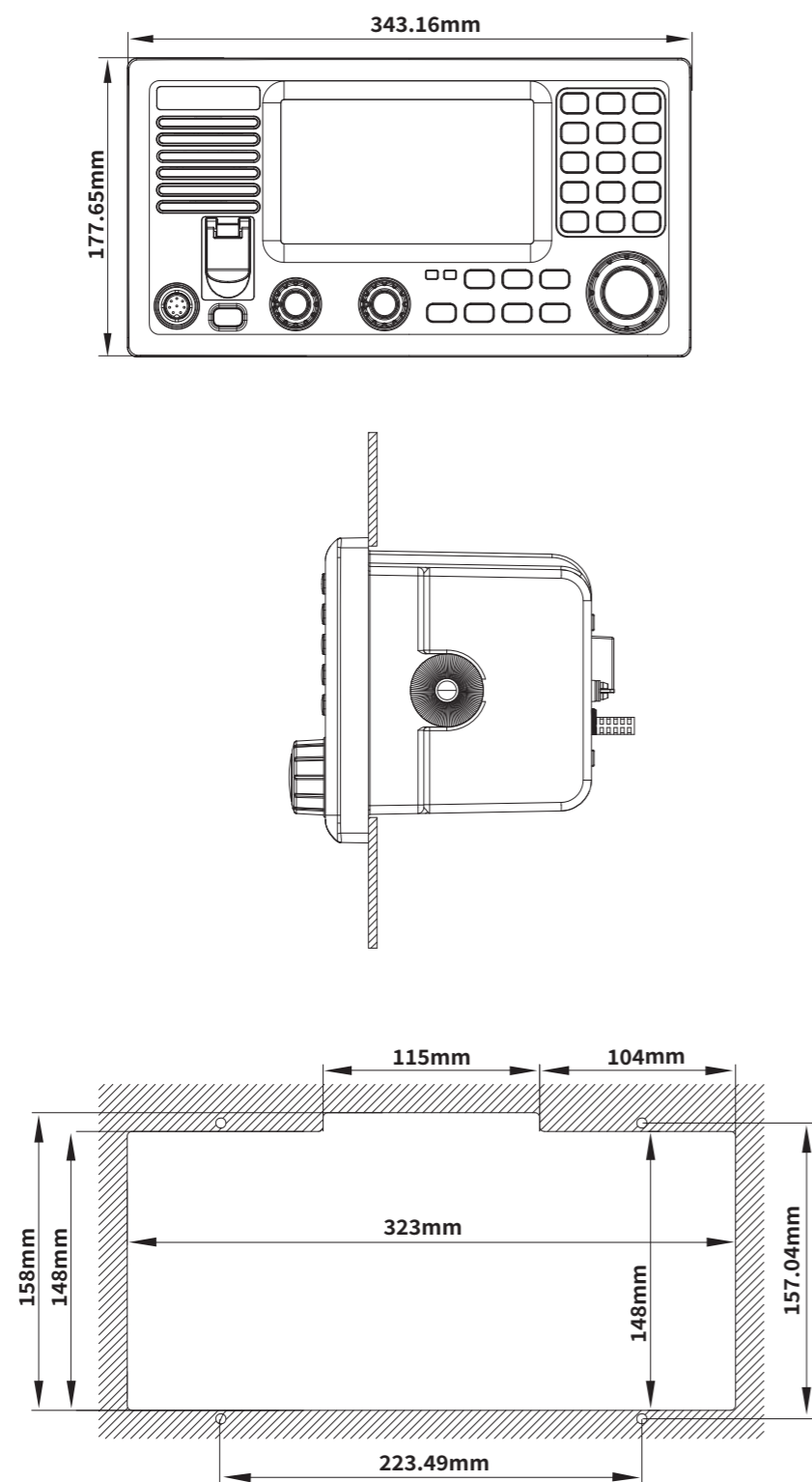

显示单元前视图说明

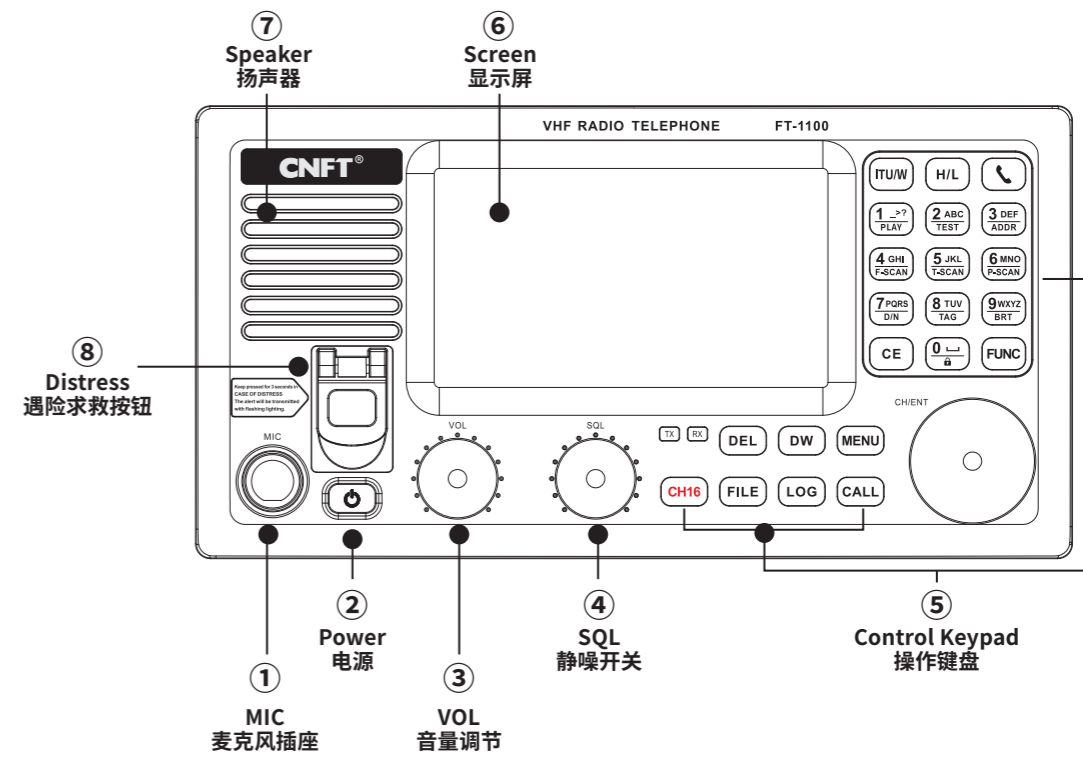

显示单元后视图说明

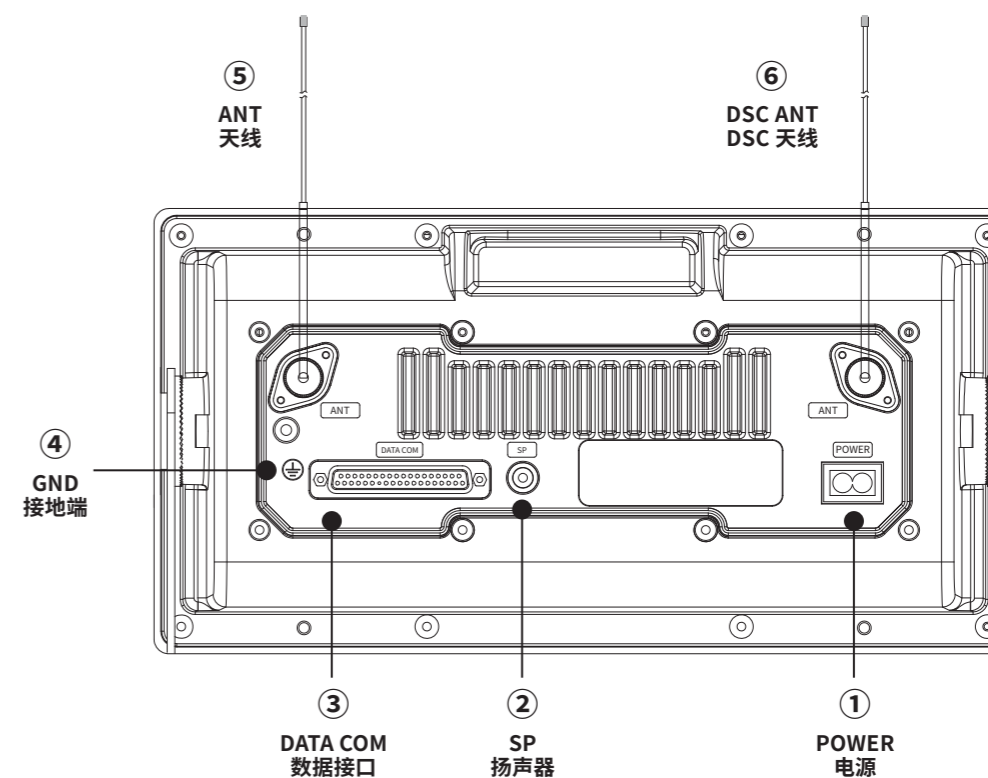

装配图

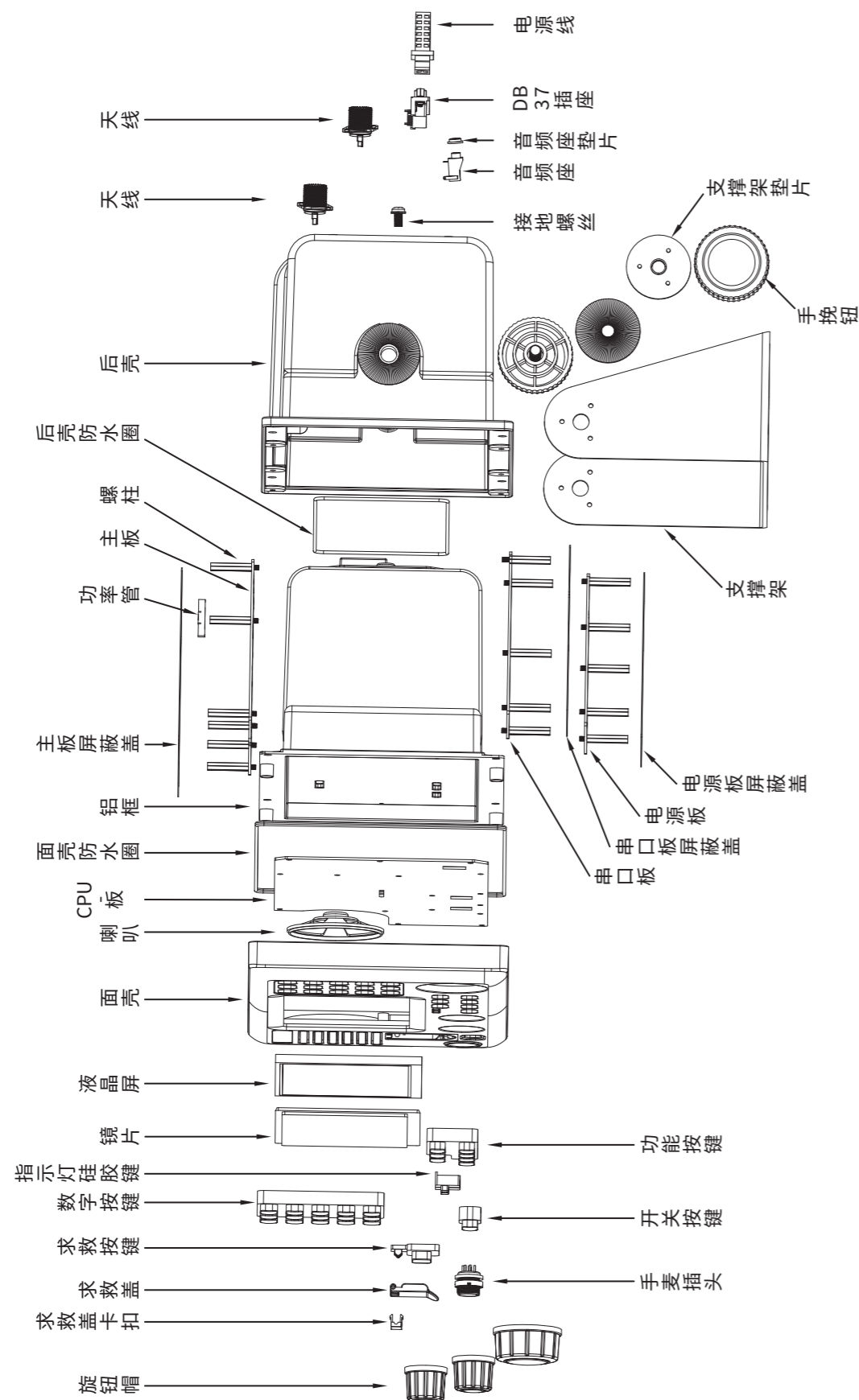

■ 天线安装

天线安装示意图

天线安装十分重要,合理的架设可减少干扰,使通讯距离达到最佳,安装时请注意以下几点:

- ① 天线应架设在垂直位置上,在水平面上应尽可能远离导电物体,最小距离不低于0.5米,天线不能靠近大型的垂直物体,并保证360°无阻挡。
- ② 天线应尽量远离大功率发射源,如雷达、电台或其他无线电天线,最好离开3米以上。
- ③ 两副天线不能在同一平面内,如在同一平面内两副天线间距应在10米以上,条件不允许可将两副天线安装成上下垂直,且高度差应超过2.5米以上。
- ④ 室外电缆接口要防水处理。
- ⑤ 天线电缆长度应尽量短,并要远离电源电缆,如果与电缆交叉应保持90°垂直。
- ⑥ 如安装在灯杆上应用绝缘物体隔离,并在高度上超过1.5米以上。

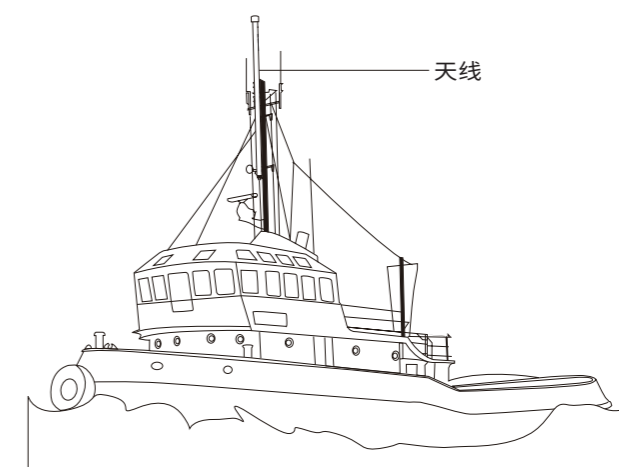

鞭状天线安装示意图

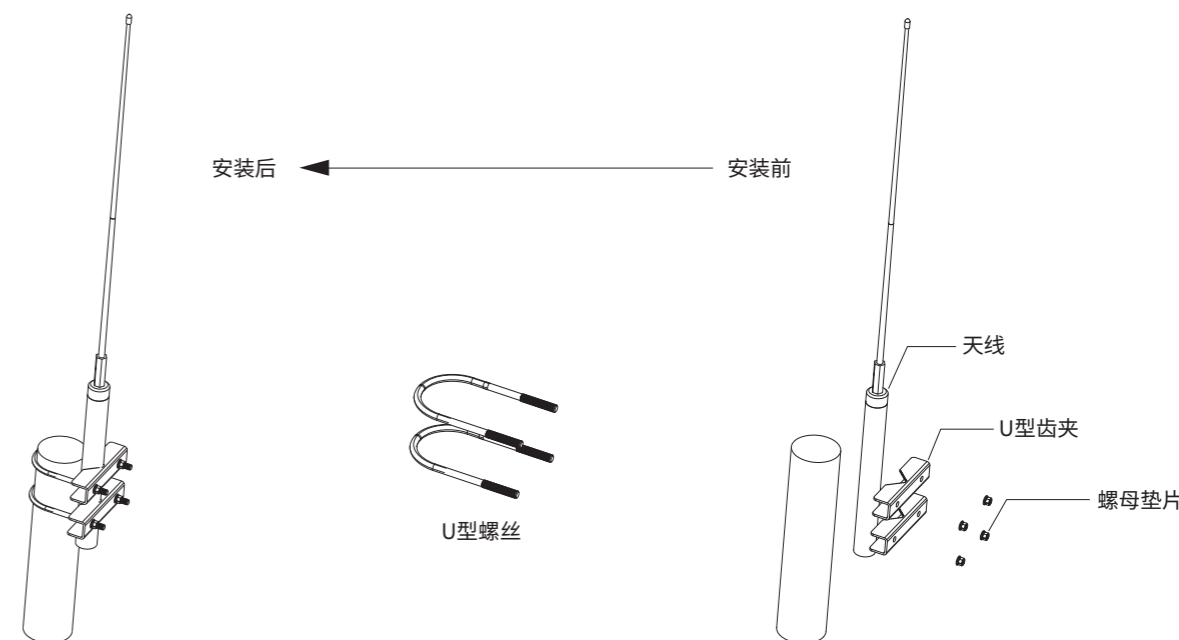

面板说明

FT-1100甚高频无线电装置(A级DSC)是配备DSC单元的多功能电台，有频段转换、扫描、看守、私有频道等功能。本机设计选择铝合金框架为主体，结合高品质的部件，增加防水措施，采用成熟合理的软、硬件技术，使用大屏幕液晶显示及简易的按键操作，使得设备更容易使用。

◇ 前面板布局图

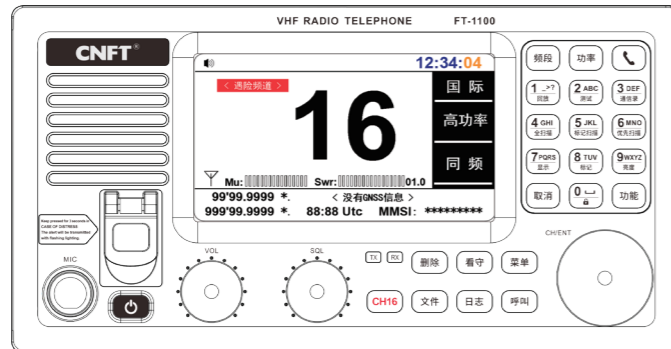

◇ 键盘操作说明

功能	数字键复用功能开启，当按下时显示器显示“功能键”标识，再按某数字键即开启该数字键的复用功能
1 .>? 回放	默认功能<数字1>，复用功能<回放> 复用功能：查看录音数据。
2 ABC 测试	默认功能<数字2>，复用功能<测试> 复用功能：打开DSC测试呼叫编辑界面，可报送/保存该呼叫
3 DEF 通信录	默认功能<数字3>，复用功能<通信录>; 复用功能：打开通信录列表
4 GHI 全扫描	默认功能<数字4>，复用功能<全扫描>; 复用功能：开启全频道扫描
5 JKL 标记扫描	默认功能<数字5>，复用功能<标记扫描>; 复用功能：开启标记/记忆频道扫描功能
6 MNO 优先扫描	默认功能<数字6>，复用功能<优先扫描>; 复用功能：开启优先频道扫描功能
7 PQR 显示	默认功能<数字7>，复用功能<显示>; 复用功能：切换主界面的主题模式，D(DAY)代表白天模式，背景为白色，字体为黑色。N(NIGHT)代表黑夜模式，背景为黑色，字体为白色。
8 TUV 标记	默认功能<数字8>，复用功能<标记>; 复用功能：标记/记忆当前频道
9 WXYZ 亮度	默认功能<数字9>，复用功能<亮度>; 复用功能：打开背景灯亮度调节对话框。
0 LOCK	默认功能<数字0>，复用功能<LOCK>; 复用功能：锁定按键/旋钮操作。该功能开启后，显示器上会显示“LOCK”标识图标(键盘锁定提示框); 此时操作按键和旋钮均无响应。可再单独按此键解除锁定，“LOCK”标识图标(提示框)消失。 *键盘被锁定期间，允许 [CH16] 和 [DISTRESS] 键响应，用于应急操作
SPKER	内置扬声器

DISTRESS	紧急遇险求救按钮：打开红色保护盖，然后长按此按钮5秒，设备将发送遇险求救呼叫
MIC	麦克风插座
POWER	电源开关：正确接通电源后，长按3秒钟开机或者关机
VOL	音量控制：调整音量输出水平，右旋增大音量，左旋减小音量
SQL	静噪控制：调整接收机静噪水平，右旋加深静噪，左旋减浅静噪
CH16	快速切换到CH16频道
删除	删除键
看守	开启双看守功能
菜单	打开系统主菜单
文件	打开保存的预先编辑的呼叫文件
日志	打开数字选择呼叫日志
呼叫	打开呼叫列表菜单，编辑要发送/保存的呼叫
CHANNEL	频道旋钮：在主界面下选择工作的频道; 在菜单下选择光标的位置。按下时，是 [确认] 功能键
频段	选择频段，按下时电台将在国际频段(INT)、美国频段(USA)、加拿大频段(CAN)、天气频段(WX)四种频段内循环选择。若选择国际频段、美国频段或加拿大频段，电台将自动转到CH16频道。若选择天气频段，电台将自动转到CH01频道
功率	切换功率，高功率(HIGH)->25W，低功率(LOW)->1W
电话	与远端话机进行内部通话请求按键
取消	取消当前操作，返回上一级菜单
LCD	10.7寸TFT显示器 [LCD]

◇ 显示界面

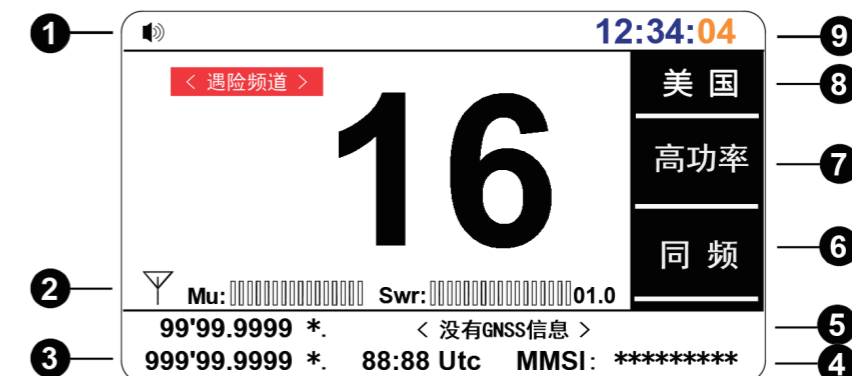

◇ 显示界面操作说明

序号	说明
1	扬声器状态
2	接收信号强度/发射输出功率指示 MU → 待机状态 TX → 发射状态 RX → 接收状态 Swr → 发射状态时天线驻波比
3	本机的GNSS信息
4	本机的9位MMSI号码
5	本机的GNSS信息输入状态
6	当前频道属性信息 同频 → RX_freq = TX_freq 异频 → RX_freq != TX_freq
7	当前频道设定输出功率状态 高功率 → 25W 低功率 → 1W NO-TX → 该频道禁止发射
8	当前频段信息 国际 → INT国际频段 美国 → USA美国频段 加拿大 → CAN加拿大频段 天气 → WX天气频段
9	本地RTC时间

基本操作

◆ 如何开机

正确接通电源后，长按3秒钟开机或者关机。

◆ 如何转换频道

旋转【CHANNEL】频道旋钮转换频道，或者直接按【数字】键输入目标频道然后按【确认】键确认。

◆ 如何进行无线电发射和接收

接收：设备开机后即进入待机状态，屏幕显示“MU”，若在当前频道上接收到信号，那么屏幕使用绿色显示“RX”和“BUSY”，信号强度指示会根据信号的强度产生变化。

发射：当按下话筒上的【PTT】键时，设备进入无线电发射状态，屏幕使用红色显示“TX”，功率输出指示会根据发射的功率的大小产生变化。

◆ 如何进行双看守

双看守功能：在当前频道和CH16频道之间交替扫描。

按面板上的【看守】键，设备将进行双看守扫描，屏幕显示“看守”图标。

当在看守频道上检测到信号时，设备将继续扫描。

当在CH16频道上检测到信号时，设备将停留在CH16频道上继续监听该信号直至消失，信号消失30秒后设备将继续扫描。设备停留期间，允许操作者按【PTT】键与对方讲话，设备将退出双看守。

按【取消】键取消看守扫描。

◆ 如何播放录音

首先按面板上的【功能】键，再按【1/回放】键打开录音回放界面，通过右旋/左旋频道旋钮选择要回放的日期，按【确认】键打开日期目录，再通过右旋/左旋频道旋钮选择要回放的录音文件，然后按【确认】键开始播放/暂停播放。按【取消】键关闭录音回放界面。

◆ 如何快速发送DSC测试呼叫

首先按面板上的【功能】键，再按【2/测试】键，打开呼叫编辑界面，详细操作请参阅本手册第5.6节。

◆ 如何进行全频道扫描

全扫描功能：扫描当前频段的所有频道。

首先按面板上的【功能】键，再按【4/全扫描】键，设备将在当前频段内扫描所有频道，包括私有频道(私有频道必须被设置)，显示器显示“全频道扫描”标识。扫描顺序可通过右旋/左旋频道旋钮设置为向上/向下扫描。

当设备在某一频道上检测到信号时，将停留在该频道上监听该信号直至消失，信号消失30秒后，设备将继续扫描。设备停留期间，允许操作者按【PTT】键与对方讲话，设备将退出扫描。按【取消】键取消全频道扫描。

◆ 如何进行标记扫描

※扫描当前频段内被标记的频道。

首先按面板上的【功能】键，再按【5/标记扫描】键，设备将在当前频段内扫描被标记的频道，包括私有频道（私有频道必须被设置），屏幕显示“标记扫描”图标。

扫描顺序可通过右旋/左旋频道旋钮设置为向上/向下扫描，当设备在某一频道上检测到信号时，将停留在该频道上监听该信号直至消失，信号消失30秒后设备将继续扫描。设备停留期间，允许操作者按【PTT】键与对方讲话，设备将退出标记扫描。

按【取消】键取消记忆频道扫描。

◆ 如何进行优先扫描

优先频道扫描功能：在当前频段内被标记的频道和CH16频道之间交替扫描。首先按面板上的【功能】键，再按【6/优先扫描】键，开启优先频道扫描功能，屏幕显示“优先扫描”，扫描顺序可通过右旋/左旋频道旋钮设置为向上/向下扫描。

当在标记频道上检测到信号时，设备将继续扫描，不停留在看守频道上。

当设备在某一频道上检测到信号时，将停留在该频道上监听该信号直至消失，信号消失30秒后设备将继续扫描。设备停留期间，允许操作者按【PTT】键与对方讲话，设备将退出扫描。

按【取消】键取消优先频道扫描。

◆ 如何切换显示模式

在主界面下，先按【功能】键，再按【7/显示】键，主界面的显示模式在日间模式和夜晚模式之间切换。

◆ 如何标记/记忆当前频道

首先按面板上的【功能】键，再按【8/标记】键或者直接按【确认】键标记/记忆当前频道。

◆ 如何调节屏幕背光和按键背光亮度

首先按面板上的【功能】键，再按【9/亮度】键打开背光亮度对话框，然后再按【功能】键选择要调节的背光选项，最后通过右旋/左旋频道旋钮设备背光等级。

遇险报警呼叫操作

※ DSC的操作须在设备有正确的MMSI号码后才可以进行，如果没有有效的MMSI号码，那么按面板上的【DIST】键和【呼叫】键时，会弹出没有MMSI号码警告提示框。以下操作默认为设备已经设置了有效的MMSI号码以及正确连接了GNSS设备。

◆ 遇险报警呼叫

◇ 发送遇险报警呼叫

a:首先按面板上的【DIST】键，打开发送遇险报警呼叫操作界面，如图4.1.1所示。

遇险报警呼叫	
呼叫目标	: 所有船
遇险船	: 888888888
遇险种类	: 未指明种类
遇险位置	: 99° 99.9999 *. 999° 99.9999 *. 88:88 Utc
通信频率	: CH-0016
发送频率	: CH-70
请按遇险键5秒钟发送遇险呼叫! 5s	

图4.1.1

b:按【确认】键打开遇险种类列表，使用频道旋钮选择遇险的种类。遇险的种类包括：火灾、进水、碰撞、搁浅、倾斜、沉没、失去动力、未指明种类、弃船、海盗、有人落水共11种。默认为未指明种类，按【确认】键确认。

c:设备允许操作者手动输入GNSS信息，旋转频道旋钮将光标转到<遇险位置>项，按【数字】键输入正确的GNSS信息（若需重新输入按【删除】键删除），然后按【确认】键确认。

d:长按【DIST】键5秒钟，5秒钟后发送遇险报警呼叫。

设备发送完遇险报警呼叫后进入等待应答呼叫模式。

在该模式下设备已经跳转到16频道上准备通话，并且在20~50秒范围内的随机时间重复发出报警声音，如果3.5~4.5分钟内没有接收到应答呼叫，那么设备自动再次发送遇险报警呼叫。

选择<停止>项，设备将停止自动重发，选择<重发>项，设备将立即重发遇险报警呼叫。

若设备被误发射了遇险报警呼叫，那么要按照如下操作及时的取消该报警：

a)在等待应答呼叫模式下选择【取消】键，发送报警取消呼叫取消该报警。

b)使用无线电在16频道上报告自己的信息。

例如：“所有船舶。。。所有船舶。。。所有船舶。。。这里是（本船的名称和本台的呼号），MMSI是XXXXXXX XX，我的位置是XX度XX分，XXX度XX分，在XXXX年XX月XX日XX点XX分取消我的未指明类型遇险报警！”

c)继续其他操作。

◇ 接收遇险报警应答呼叫

当设备接收到遇险报警应答呼叫时，会发出报警声音，显示报警应答呼叫包含的信息，如图4.1.2所示，同时设备已经跳转到16频道等待通话。



图4.1.2

◇ 接收遇险报警呼叫

当设备接收到遇险报警呼叫时，会发出报警声音，显示报警呼叫包含的信息，如图4.1.3所示，同时设备已经自动转到16频道等待通话。

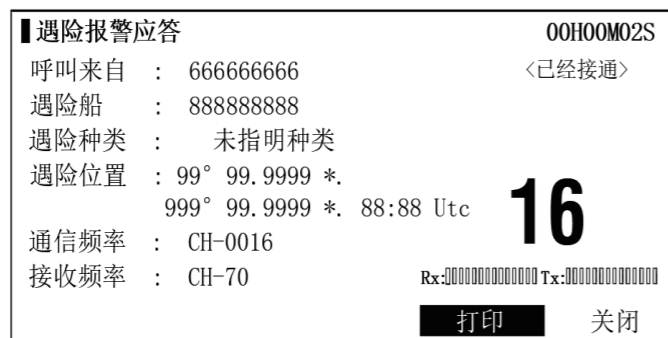

图4.1.3

若要转发该条报警，那么选择<转发>项，按【确认】键，打开转发类型菜单，选择转发到单台或所有台，然后再按【确认】键发送呼叫。

若要发送遇险报警应答呼叫，那么选择<ACK>项，按【确认】键发送应答呼叫。

按【取消】键或者选择<关闭>项返回到主界面操作。

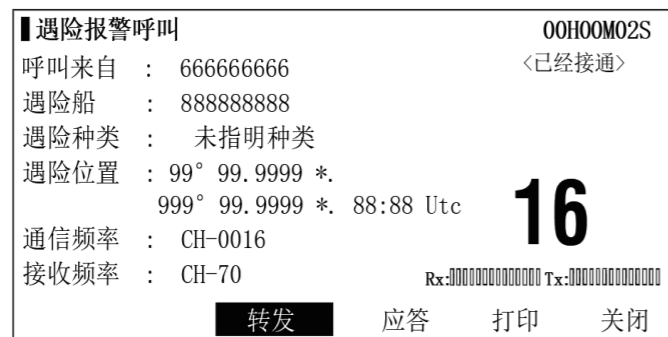
◆ 遇险报警转发呼叫

◇ 将遇险报警转发到所有台

a:按面板上的【呼叫】键，打开呼叫类型列表。

b: 使用频道旋钮选择<转发遇险报警到所有台>项，按【确认】键打开编辑界面。如图4.2.1所示。



图4.2.1

c: 旋转频道旋钮选择<遇险船>项，使用数字键盘输入遇险船的MMSI号码，也可以按【确认】键，打开通讯录，从通讯录中选择MMSI号码。

d: 旋转频道旋钮选择<遇险种类>项，遇险的种类包括：火灾、进水、碰撞、搁浅、倾斜、沉没、失去动力、未指明种类、弃船、海盗、有人落水共11种，默认为未指明种类,按【确认】键确认。

e: 设备允许操作者手动输入GNSS信息，旋转频道旋钮选择<遇险位置>项，按【数字】键打开GNSS信息输入输入正确的GNSS信息，然后按【确认】键确认。

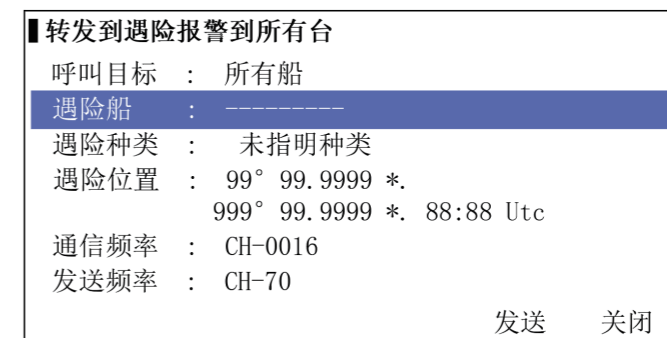
f: 旋转频道旋钮选择<发送>项，按【确认】键发送遇险报警转发呼叫。发送完毕后设备自动跳转到16频道上准备通话。

◇ 接收转发到所有台的遇险报警呼叫

参见4.1.3节接收遇险报警呼叫的操作。

◇ 将遇险报警转发到单台

a: 按面板上的【呼叫】键，打开呼叫类型列表。

b: 使用频道旋钮选择<转发遇险报警到单台>项，按【确认】键打开编辑界面，如图4.2.3所示。



图4.2.3

c: 旋转频道旋钮选择<呼叫目标>项, 使用数字键盘输入遇险船的MMSI号码, 也可以按【确认】键, 打开通讯录, 从通讯录中选择MMSI号码。

d: 旋转频道旋钮选择<遇险船项>, 使用数字键盘输入遇险船的MMSI号码, 也可以按【确认】键, 打开通讯录, 从通讯录中选择MMSI号码。

e: 旋转频道旋钮选择<遇险种类>项, 遇险的种类包括: 火灾、进水、碰撞、搁浅、倾斜、沉没、失去动力、未指明种类、弃船、海盗、有人落水共11种。默认为未指明种类, 按【确认】键确认。

f: 设备允许操作者手动输入GNSS信息, 旋转频道旋钮选择<遇险位置>项, 按【数字】键输入正确的GNSS信息(若需重新输入按【删除】键删除), 然后按【确认】键确认。

g: 旋转频道旋钮选择<发送>项, 按【确认】键发送遇险报警转发呼叫。发送完毕后设备转到等待应答界面, 并自动跳转到16频道上准备通话

◇ 接收转发到单台的遇险报警应答呼叫

参见4.1.2节接收遇险报警应答呼叫的操作。

◇ 接收转发到单台的遇险报警呼叫

参见4.1.3节接收遇险报警呼叫的操作。

普通呼叫操作

※ DSC的操作须在设备有正确的MMSI号码后才可以进行, 如果没有有效的MMSI号码, 那么面板上的【DIST】键和【呼叫】键时, 会弹出没有MMSI号码警告提示框。

以下操作默认为设备已经设置了有效的MMSI号码以及正确连接了GNSS设备。

◆ 单台呼叫

◇ 发送单台呼叫

a: 面板上的【呼叫】键, 打开呼叫类型列表。

b: 使用频道旋钮选择<单台>项, 按【确认】键打开编辑界面, 如图5.1.1所示。



图5.1.1

c: 旋转频道旋钮选择<呼叫目标>项, 使用数字键盘输入目标船的MMSI号码, 也可以按【确认】键, 打开通讯录, 从通讯录中选择MMSI号码。

d: 旋转频道旋钮选择<遇险种类>项, 按【确认】键打开呼叫级别列表, 选择后按【确认】键确认。

e: 旋转频道旋钮选择<通信频率>项, 使用【数字】键输入频道号码。

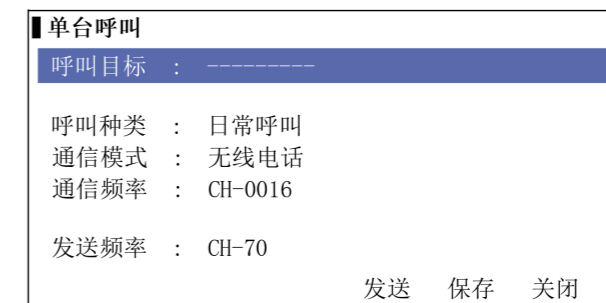
f: 旋转频道旋钮选择<发送>项, 按【确认】键发送该条呼叫。

g: 发送完呼叫后, 设备等待应答呼叫, 可以选择<RSEND>项, 按【确认】键再一次发送该条呼叫。

※ 选择<保存>项, 将该条呼叫保存到呼叫文件中。

◇ 接收单台应答呼叫

当设备接收到单台应答呼叫时, 会发出提示声音。显示应答呼叫包含的信息, 如图5.1.2所示, 同时设备已经跳转到通信频道上等待通话。



图5.1.2

选择<打印>项,按【确认】键打印该条呼叫。

选择<关闭>项,按【确认】键关闭该界面,返回到主界面操作。

◇ 接收单台呼叫

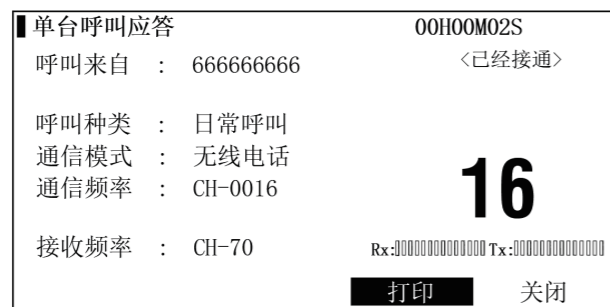
当设备接收到单台呼叫时,会发出提示声音,显示该呼叫包含的信息,如图5.1.3所示。



图5.1.3

如果需要应答,则选择<应答>项,按【确认】键发送应答呼叫,发送完毕后设备自动转到到通信频道准备通话。

如果需要半应答,则选择<半应答>项,按【确认】键打开半应答原因对话框,选择相应的原因后,按【确认】键确认,发送半应答呼叫,发送完毕后返回到主界面。

选择<打印>项,按【确认】键打印该条呼叫。

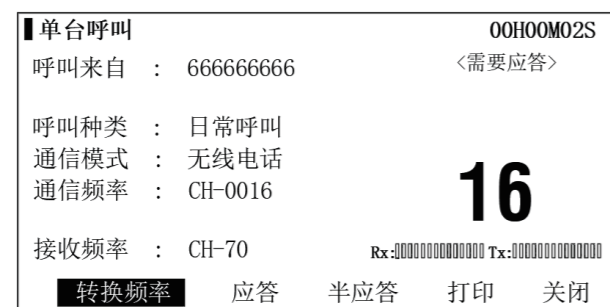
选择<关闭>项,按【确认】键关闭该界面,返回到主界面操作。

◆ 所有台呼叫

◇ 发送所有台呼叫

a:按面板上的【呼叫】键,打开呼叫类型列表。

b:使用频道旋钮选择<所有台呼叫>项,按【确认】键打开编辑界面,如图5.2.1所示。



图5.2.1

c:旋转频道旋钮选择<呼叫种类>项,按【确认】键打开呼叫种类列表,选择后按【确认】键确认。

d:旋转频道旋钮选择<通信频率>项,使用数字键盘输入频道号码。

e:旋转频道旋钮选择<发送>项,按【确认】键发送该条呼叫。

f:发送完呼叫后,设备已经转到通信频道上准备通话,也可以选择<重发>项,按【确认】键再一次发送该条呼叫。

※ 选择<保存>项,将该条呼叫保存到呼叫文件中。

◇ 接收所有台呼叫

当设备接收到所有台呼叫时,会发出提示声音,显示该呼叫包含的信息,如图5.2.2所示。



图5.2.2

如果在数字选呼菜单中的频率转换设置为自动模式，那么设备在收到呼叫的时候将自动转换频道，否则在接收到呼叫时，设备的当前频道并未转换到通信频道上，需要用户选择<转换频率>项，按【确认】键转换到通信频率。

选择<打印>项，按【确认】键打印该条呼叫。

选择<关闭>项，按【确认】键关闭该界面，返回到主界面操作。

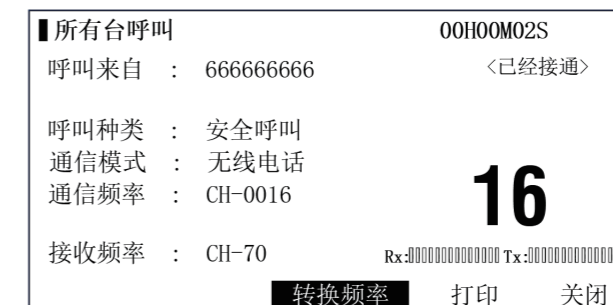
◆ 群组呼叫

◇ 发送群组呼叫

a:按面板上的【呼叫】键，打开呼叫类型列表。

b:使用频道旋钮选择<群组呼叫>项，按【确认】键打开编辑界面,如图5.3.1所示。



图5.3.1

c:旋转频道旋钮选择<群组号码>项，使用数字键盘输入群组的ID号码，也可以按【确认】键，打开通讯录，从通讯录中选择群组ID号码。

d:旋转频道旋钮选择<遇险种类>项，按【确认】键打开呼叫种类列表，选择后按【确认】键确认。

e:旋转频道旋钮选择<通信频率>项，使用数字键盘输入频道号码。

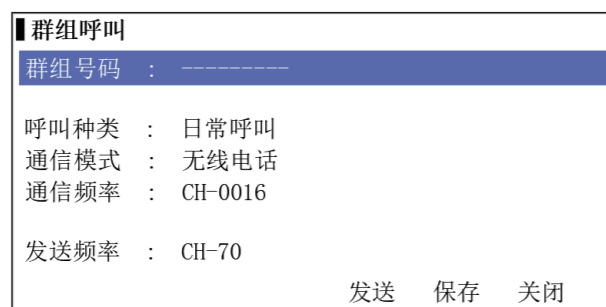
f:旋转频道旋钮选择<发送>项，按【确认】键发送该条呼叫。

g:发送完呼叫后，设备已经转到通信频道上准备通话，也可以选择<重发>项，按【确认】键再一次发送该条呼叫。

※群组呼叫的呼叫种类仅可以选择日常呼叫。

※选择<保存>项，将该条呼叫保存到呼叫文件中。

◇ 接收群组呼叫

当设备接收到群组呼叫时，会发出提示声音，显示该呼叫包含的信息，如图5.3.2所示。



图5.3.2

如果在数字选呼菜单中的频率转换设置为自动模式，那么设备在收到呼叫的时候将自动转换频道，否则在接收到呼叫时，设备的当前频道并未转换到通信频道上，需要用户选择<转换频率>项，按【确认】键转换到通信频率。

选择<打印>项，按【确认】键打印该条呼叫。

选择<关闭>项，按【确认】键关闭该界面，返回到主界面操作。

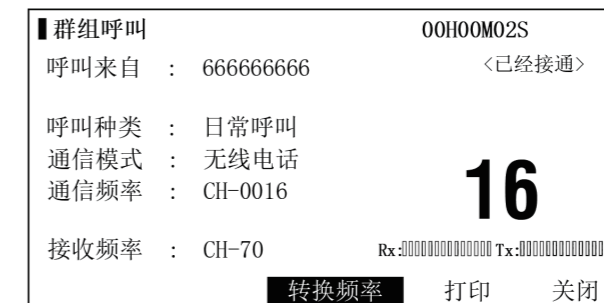
◆ 电话呼叫

◇ 发送电话呼叫

a:按面板上的【呼叫】键，打开呼叫类型列表。

b:使用频道旋钮选择<电话呼叫>项，按【确认】键打开编辑界面,如图5.4.1所示。



图5.4.1

c:旋转频道旋钮选择<呼叫目标>项，使用数字键盘输入目标的MMSI号码，也可以按【确认】键，打开通讯录，从通讯录中选择MMSI号码。

d:旋转频道旋钮选择<电话号码>项，使用数字键盘输入要接通的电话号码，也可以按【确认】键打开通讯录，从通讯录中选择电话号码。

e:旋转频道旋钮选择<发送>项,按【确认】键发送该条呼叫。

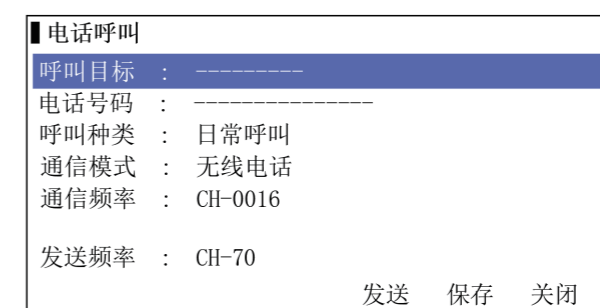
f:发送完呼叫后,设备等待应答呼叫,可以选择<重发>项,按【确认】键再一次发送该条呼叫。

※选择<保存>项,将该条呼叫保存到呼叫文件中。

◇ 接收电话应答呼叫

当设备接收到电话应答呼叫时,会发出提示声音。显示应答呼叫包含的信息,如图5.4.2所示,同时设备已经跳转到通话频道上等待通话。



图5.4.2

选择<打印>项,按【确认】键打印该条呼叫。

选择<关闭>项,按【确认】键关闭该界面,返回到主界面操作。

◇ 接收电话呼叫

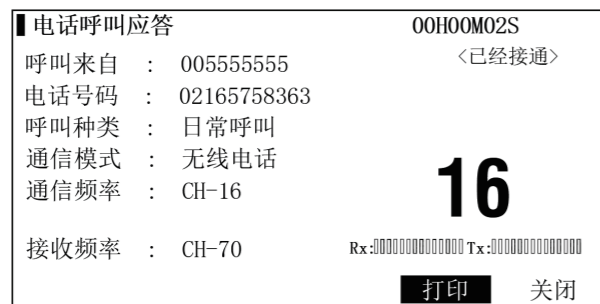
当设备接收到电话呼叫时,会发出提示声音,显示该呼叫包含的信息,如图5.4.3所示。



图5.4.3

如果需要应答,则选择<应答>项,按【确认】键发送应答呼叫,发送完毕后设备自动转到到通信频道准备通话。

如果需要半应答,则选择<半应答>项,按【确认】键打开半应答原因对话框,选择相应的原因后,按【确认】键确认,发送半应答呼叫,发送完毕后返回到主界面。

选择<打印>项,按【确认】键打印该条呼叫。

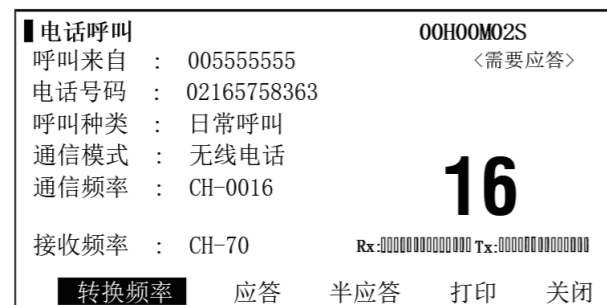
选择<关闭>项,按【确认】键关闭该界面,返回到主界面操作。

◆ 位置请求呼叫

◇ 发送位置请求呼叫

a:按面板上的【呼叫】键,打开呼叫类型列表。

b:使用频道旋钮选择<位置请求呼叫>项,按【确认】键打开编辑界面,如图5.5.1所示。



图5.5.1

c:旋转频道旋钮选择<呼叫目标>项,使用数字键盘输入目标船的MMSI号码,也可以按【确认】键,打开通讯录,从通讯录中选择MMSI号码。

d:旋转频道旋钮选择<发送>项,按【确认】键发送该条呼叫。

e:发送完呼叫后,设备等待应答呼叫,可以选择<重发>项,按【确认】键再一次发送该条呼叫。

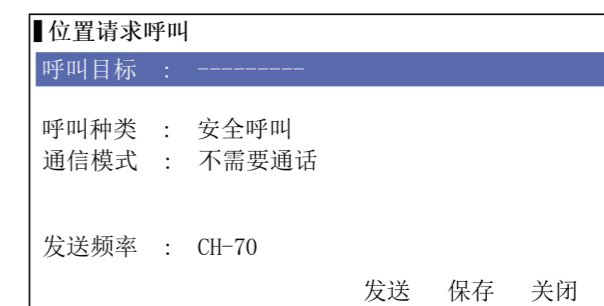
※选择<保存>项,将该条呼叫保存到呼叫文件中。

◇ 接收位置请求应答呼叫

当设备接收到位置请求应答呼叫时,会发出提示声音,显示应答呼叫包含的信息,如图5.5.2所示。



图5.5.2

选择<打印>项,按【确认】键打印该条呼叫。

选择<关闭>项,按【确认】键关闭该界面,返回到主界面操作。

◇ 接收位置请求呼叫

当设备接收到位置请求呼叫时,会发出提示声音,显示该呼叫包含的信息,如图5.5.3所示。



图5.5.3

选择<应答>项,按【确认】键发送应答呼叫。

选择<打印>项,按【确认】键打印该条呼叫。

选择<关闭>项,按【确认】键关闭该界面,返回到主界面操作。

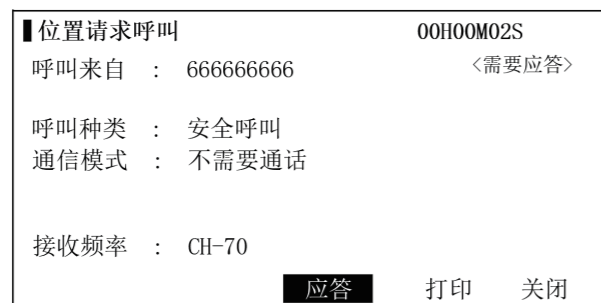
◆ 测试呼叫

◇ 发送测试呼叫

a:按面板上的【呼叫】键,打开呼叫类型列表。

b:使用频道旋钮选择<测试呼叫>项,按【确认】键打开编辑界面,如图5.6.1所示。



图5.6.1

c: 旋转频道旋钮选择<呼叫目标>项,使用数字键盘输入目标船的MMSI号码,也可以按【确认】键,打开通讯录,从通讯录中选择MMSI号码。

d:旋转频道旋钮选择<发送>项,按【ENT】键发送该条呼叫。

e:发送完呼叫后,设备等待应答呼叫,可以选择<重发>项,按【确认】键再一次发送该条呼叫。

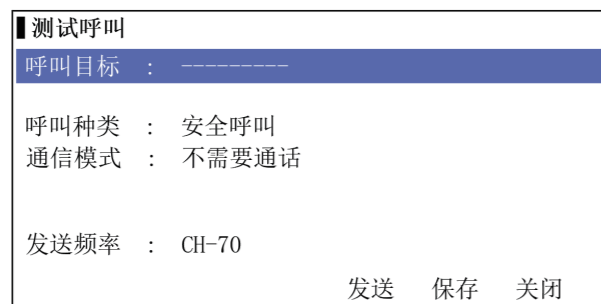
※选择<保存>项,将该条呼叫保存到呼叫文件中。

◇ 接收测试应答呼叫

当设备接收到测试应答呼叫时,会发出提示声音,显示应答呼叫包含的信息,如图5.6.2所示。



图5.6.2

选择<打印>项,按【确认】键打印该条呼叫。

选择<关闭>项,按【确认】键关闭该界面,返回到主界面操作。

◇ 接收测试呼叫

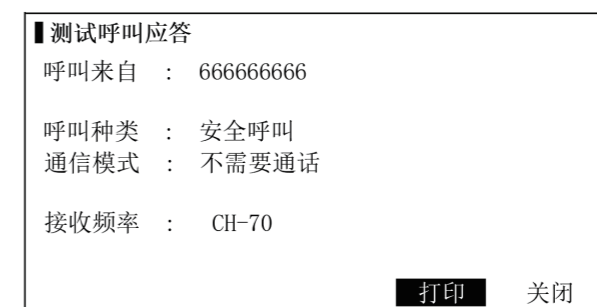
当设备接收到测试呼叫时,会发出提示声音,显示该呼叫包含的信息,如图5.6.3所示。



图5.6.3

选择<应答>项,按【确认】键发送应答呼叫。

选择<打印>项,按【确认】键打印该条呼叫。

选择<关闭>项,按【确认】键关闭该界面,返回到主界面操作。

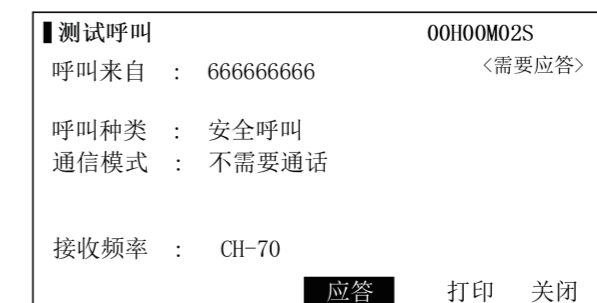
◆ 数据呼叫

呼叫列表中选择<数据呼叫>项。参见本手册第5.1节有关单台呼叫的操作。



图5.7.1



图5.7.2

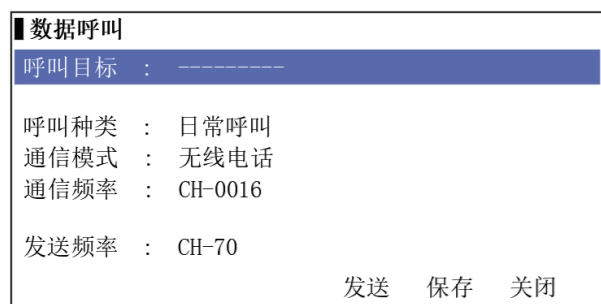

图5.7.3

◆ 中立船呼叫

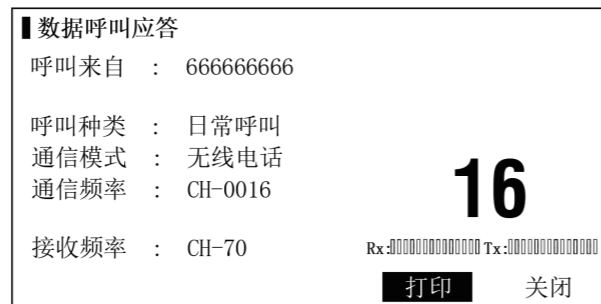
※ 只有在设备的特殊呼叫被使能情况下才可以发送中立船呼叫。使能特殊呼叫操作详见菜单操作。

呼叫列表中选择<中立船呼叫>项。参见本手册第5.2节有关所有台呼叫的操作。

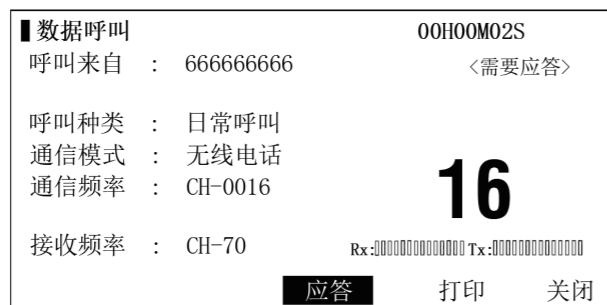
中立船呼叫的呼叫种类仅为紧急呼叫。



图5.8.1



图5.8.2

◆ 医疗船呼叫

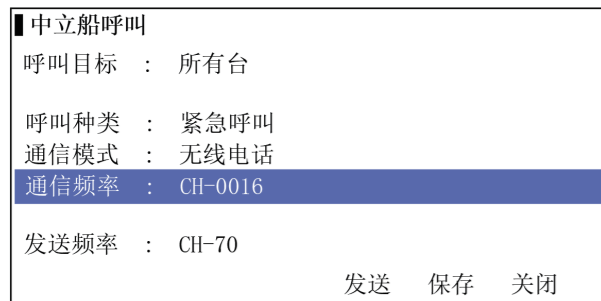
※ 只有在设备的特殊呼叫被使能情况下才可以发送医疗船呼叫。使能特殊呼叫操作详见菜单操作。

呼叫列表中选择<医疗船呼叫>项。参见本手册第5.2节有关所有台呼叫的操作。

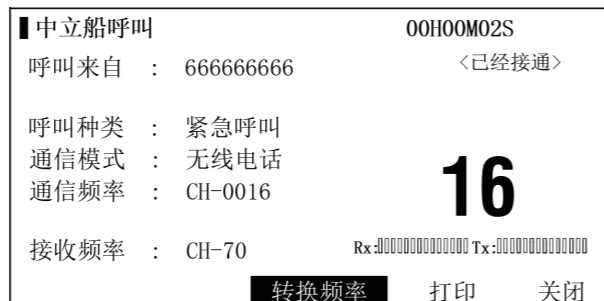
医疗船呼叫的呼叫种类仅为紧急呼叫。



图5.9.1



图5.9.2

◆ 查询呼叫

※ 设备仅接收查询呼叫

当设备接收到查询呼叫时，会发出提示声音，显示该呼叫包含的信息，如图5.10.1所示。

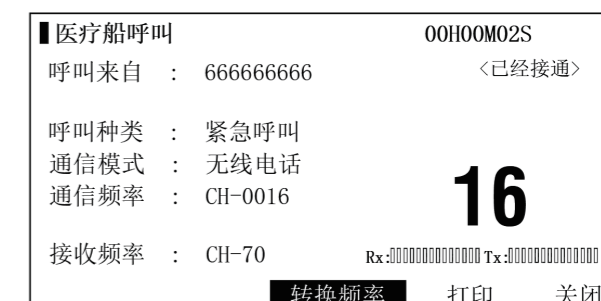
选择<应答>项，按【确认】键发送应答呼叫。

选择<打印>项，按【确认】键打印该条呼叫。

选择<关闭>项，按【确认】键关闭该界面，返回到主界面操作。



图5.10.1

菜单操作

◆ 如何使用菜单

按面板上的【菜单】键打开主菜单, 旋转【CHANNEL】频道旋钮选择要进入的子菜单或操作项, 再按【确认】键确认并进入子菜单。按【取消】键返回上一级菜单。



图6.1

◆ 编辑用户频道

设备可以使用200个用户频道, 使用之前必须先设置用户频道的发送和接收频率。

如何编辑用户频道:

- a: 在主菜单中, 选择<编辑用户频道>项, 按【确认】键打开频道信息列表。
- b: 选择需要编辑的频道号码, 然后按【确认】键打开频道操作对话框, 如图6.2.1所示, 选择<编辑选中的频道>, 按【确认】键打开编辑对话框。



图6.2.1



图6.2.2

- c: 使用【数字】键输入发射频率和接收频率, 然后旋转【CHANNEL】频道旋钮选择<SAVE>项, 按【确认】键保存。

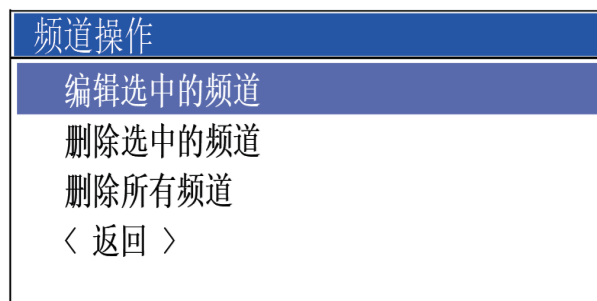
如何删除用户频道:

在本节b步骤打开的频道操作对话框中, 旋转【CHANNEL】频道旋钮选择<删除选中的频道>项或者<删除所有频道>项, 然后按【确认】键后设备将删除对应的频道。

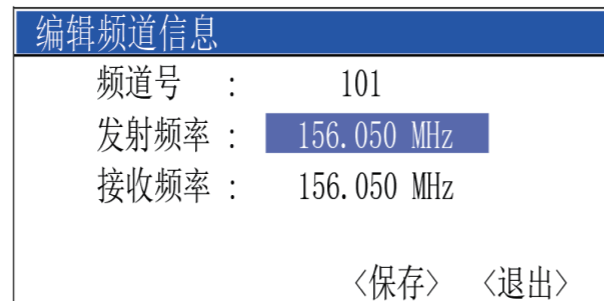
※用户频道的发射/接收频率必须要在海事频率的范围内, 并且要能被25KHz整除。

◆ 通讯录

设备允许操作者存储20条船舶、20条岸台, 20条群组的MMSI号码和20条电话号码, 方便在发送呼叫时输入。

如何增加/编辑一个条目:

- a: 在主菜单中选择<通讯录>项, 按【确认】键打开通讯录列表, 选择要编辑的条目类型, 按【确认】键打开通讯录列表。
- b: 旋转【CHANNEL】频道旋钮选择要编辑的条目, 按【确认】键打开条目操作对话框, 如图6.3.1所示。



图6.3.1



图6.3.2

- c: 旋转【CHANNEL】频道旋钮选择<编辑选中的条目>项, 按【确认】键打开编辑条目信息对话框, 使用数字键输入条目的名称和号码。

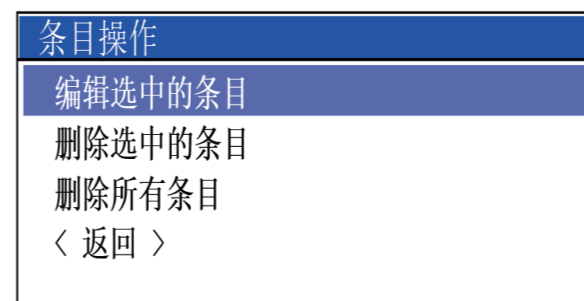
- d: 信息输入完毕后, 旋转【CHANNEL】频道旋钮到<SAVE>项, 按【确认】键确认保存。

如何删除条目:

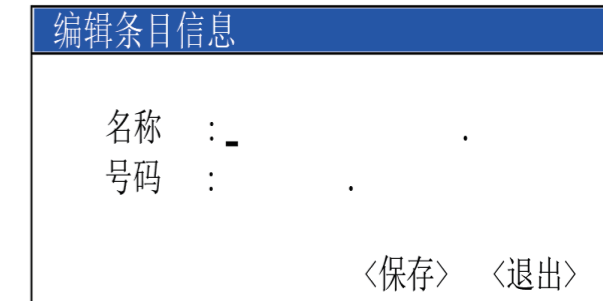
在本节b步骤打开的条目操作对话框中, 旋转【CHANNEL】频道旋钮选择<删除选中的条目>项或者<删除所有条目>项, 按【确认】键后设备将删除对应的条目。

◆ 呼叫文件

设备可以保存预先编辑的100条普通呼叫。

- a: 在主菜单中选择<呼叫文件>项, 按【确认】键打开呼叫文件列表;

b:旋转【CHANNEL】频道旋钮(也可按【数字3】和【数字9】键进行翻页)选择要操作的呼叫,按【确认】键打开操作对话框,如图6.4所示。



图6.4

c:旋转频道旋钮选择要进行的操作(查看,删除)。

d:按【取消】键退出文件列表。

◆ 呼叫日志

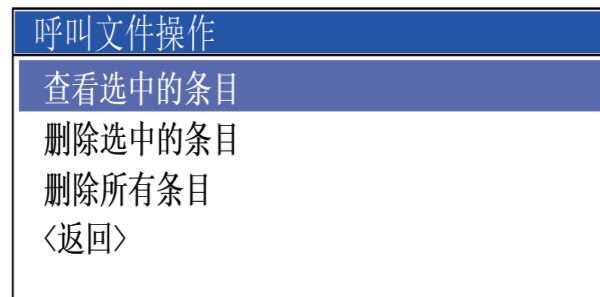
设备可以保存发射和接收的报警呼叫与普通呼叫,每种类型的呼叫可以保存100条。

a:在主菜单中选择<呼叫日志>项,按【确认】键打开呼叫日志列表。



图6.5

b:旋转【CHANNEL】频道旋钮选择要查看的呼叫类型,按【确认】键打开相应的呼叫日志文件列表。

c:旋转【CHANNEL】频道旋钮(也可按【数字3】和【数字9】键进行翻页)选择要操作的呼叫,按【确认】键打开呼叫日志操作对话框,如图6.5所示。

c:旋转频道旋钮选择要进行的操作(查看,删除)。

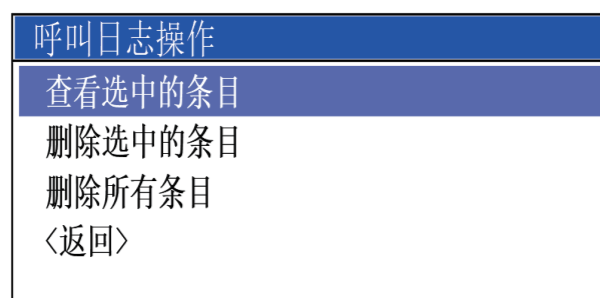
d:按【取消】键退出文件列表。

◆ 系统设置

◇ 本地时间设置

设备内部有RTC时间模块,可以产生本地日期和时间。

如何设置内部RTC:

a:在系统设置菜单中选择<本地时间设置>项,按【ENT】键打开本地时间设置对话框,如图6.6.1所示。

b:使用数字键输入日期与时间信息,也可旋转【CHANNEL】频道旋钮控制光标的位置,更改该位置上的数字。输入完毕后按选择<保存>项,按【确认】键保存时间信息。



图6.6.1

◇ 时差设置

当设备接收到有效的GNSS数据时,设备可以通过UTC时间计算出本地时间并显示在主界面上。

计算公式为: $RTC = UTC + \text{时差}$

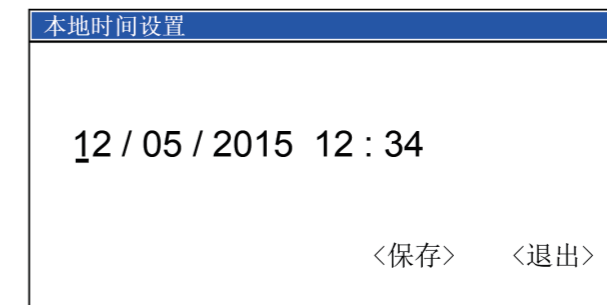
如何设置时差:

a:在系统设置菜单中选择<时差设置>项,按【确认】键打开时差设置对话框,如图6.6.2所示。

b:按【确认】键打开时差列表,可选择-12小时~+12小时。

c:旋转频道旋钮选择要设置的时差,按【确认】键确认。

d:按【取消】键返回到系统设置菜单。



图6.6.2

◇ 超时设置

在操作者按PTT的时间超出设定的时间时，设备将自动关闭发射机终止发射。

如何设置超时时间：

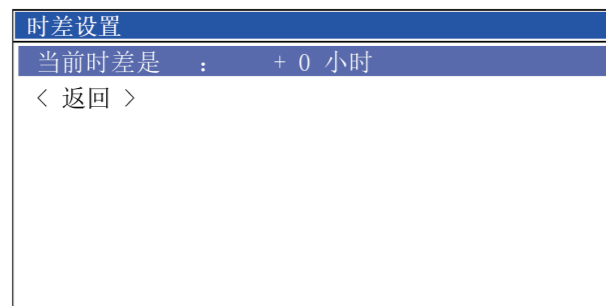
- a:在系统设置菜单中选择<超时设置>项，按【确认】键打开超时时间设置对话框，如图6.6.3所示。
- b:按【确认】键打开超时时间列表，可选择1分钟，3分钟，5分钟和无限制。
- c:旋转频道旋钮选择要设置的超时时间，按【确认】键确认。
- d:按【取消】键返回到系统设置菜单。



图6.6.3

◇ 扬声器设置

设备在前面板上内置了扬声器，另外也支持外接扬声器，根据用户需要进行选择。

- a:在系统设置菜单中选择<扬声器设置>项，按【确认】键打开扬声器设置对话框，如图6.6.4所示。

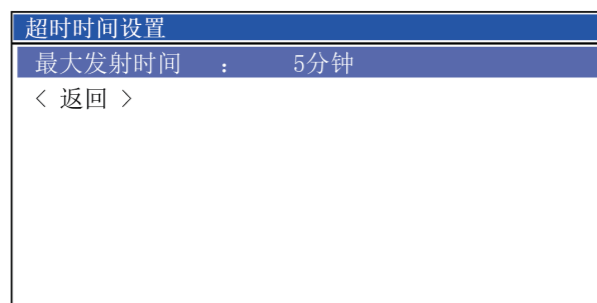
- b:按【确认】键打开扬声器类型列表，可选择内部扬声器或者外部扬声器。
- c:旋转频道旋钮选择要设置的扬声器类型，按【确认】键确认。
- d:按【取消】键返回到系统设置菜单。



图6.6.4

◇ 语言设置

设备支持中文和英文显示。

- a:在系统设置菜单中选择<语言设置>项，按【确认】键打开选择语言对话框，如图6.6.5所示。
- b:按【确认】键打开语言类型列表，可选择中文或者英文。
- c:旋转频道旋钮选择要设置的语言，按【确认】键确认，返回到主界面。



图6.6.5

◇ 声音设置

设备允许用户关闭按键声音和错误操作提示音。

- a:在系统设置菜单中选择<声音设置>项，按【确认】键打开声音设置对话框，如图6.6.6所示。

- b: 旋转频道旋钮选择要设置的声音类型，按【确认】键打开状态列表，可选择开启或者关闭。
- c: 旋转频道旋钮选择状态，按【确认】键确认。
- d: 按【取消】键返回到系统设置菜单。



图6.6.6

◇ 通信速率设置

- a: 在系统设置菜单中选择<通信速率设置>项，按【确认】键打开通信速率设置对话框，如图6.6.7所示。
 - b: 旋转频道旋钮选择速率选择要设置的项，按【确认】键打开速率列表，可选择4800bps, 9600bps, 19200bps, 38400bps, 115200bps。
 - c: 旋转频道旋钮选择速率，按【确认】键确认。
 - d: 按【取消】键返回到系统设置菜单。
- ※ 连接GNSS时一定要选择对应的速率，一般GPS的输入速率是4800bps，北斗的输入速率是9600bps。

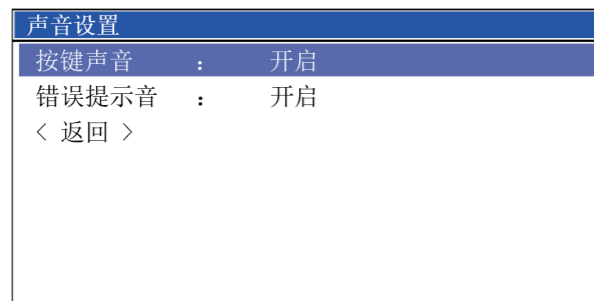

图6.6.7

◇ 显示模式设置

- a: 在系统设置菜单中选择<显示模式设置>项，按【确认】键打开显示模式设置对话框，如图6.6.8所示。
- b: 旋转频道旋钮选择速率选择要设置的项，按【确认】键打开显示模式列表，可选择明亮和暗黑两种模式。
- c: 旋转频道旋钮选择要设置的模式，按【确认】键确认。
- d: 按【取消】键返回到系统设置菜单。

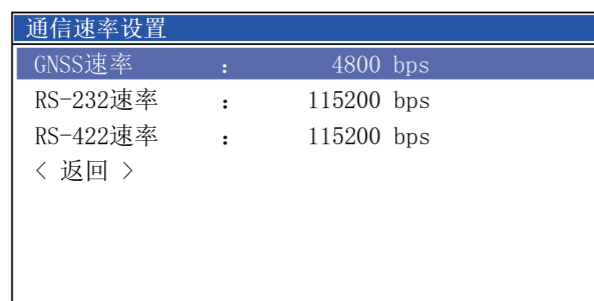

图6.6.8

◇ 录音设置

- a: 在系统设置菜单中选择<录音设置>项，按【确认】键打开录音设置对话框，如图6.6.9所示。
- b: 按【确认】键打开录音时间列表，可选择1~7天。
- c: 旋转频道旋钮选择要设置的时间，按【确认】键确认。
- d: 按【取消】键返回到系统设置菜单。

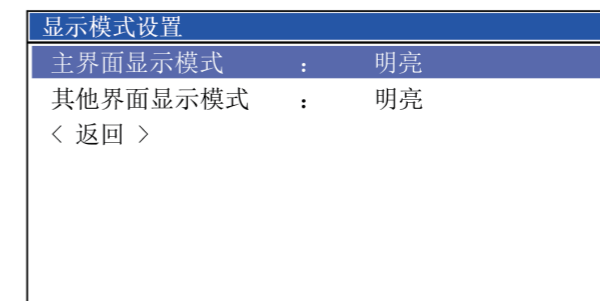

图6.6.9

◆ 数字选呼设置

◇ 本机MMSI设置

设备可以允许用户更改3次本机MMSI号码，超过3次后要输入更改密码才可以继续更改MMSI号码。

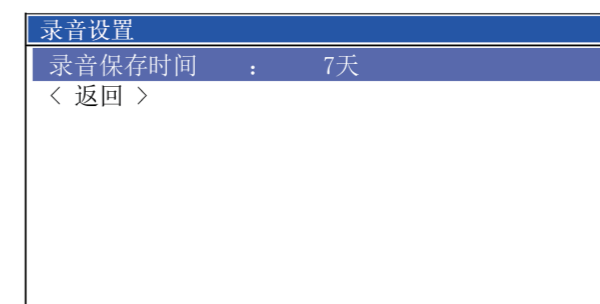
a:在数字选呼设置菜单中选择<本机MMSI设置>项，按【确认】键打开本机MMSI号码设置对话框，如图6.7.1所示。

b:使用【数字】键输入MMSI号码信息，旋转【CHANNEL】频道旋钮控制光标的位置，更改该位置上的数字。

输入完毕后按选择<SAVE>项保存时间信息。

c:按【确认】键返回到数字选呼设置菜单。



图6.7.1

◇ 位置设置

当设备没有外接GNSS时，设备允许用户手动输入GNSS信息。

a:在数字选呼设置菜单中选择<GNSS信息设置>项，按【确认】键打开GNSS信息设置对话框,如图6.7.2所示。

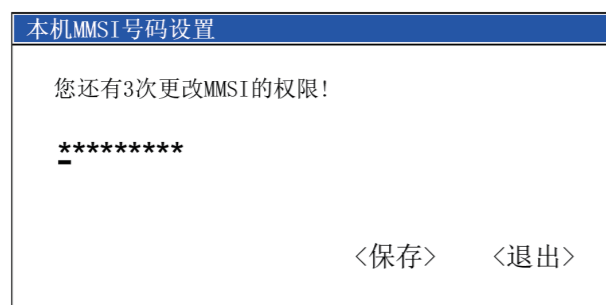
b:使用【数字】键输入GNSS信息，旋转【CHANNEL】频道旋钮控制光标的位置，更改该位置上的数字。

输入完毕后按选择<保存>项保存时间信息。

c:按【确认】键返回到数字选呼设置菜单。



图6.7.2

◇ 应答设置

设备允许用户自行设置呼叫的应答模式，所有呼叫的应答模式默认为手动应答。

a:在数字选呼设置菜单中选择<应答设置>项，按【确认】键打开应答设置对话框,如图6.7.3所示。

b:旋转【CHANNEL】频道旋钮选择要设置的呼叫类型，按【确认】键打开应答模式列表，可选择手动应答,自动应答等。

c:旋转【CHANNEL】频道旋钮选择应答模式，按【确认】键确认。

应答设置		
单呼	:	手动
电话呼叫	:	手动
UNABLE原因	:	无原因
位置请求呼叫	:	手动
测试呼叫	:	手动
查询呼叫	:	手动
< 返回 >		

图6.7.3

d:按【取消】键返回到数字选呼设置菜单。

※UNABLE原因是当应答模式设置为自动应答(UNABLE)模式时，需要设置的UNABLE原因。

◇ 打印设置

设备支持连接串口打印机(需连接指定型号，具体请咨询供应商)，当发送或者接收到呼叫时打印呼叫信息。

设备可以设置打印模式为自动打印或者手动打印两种模式，设备默认是手动打印模式。

a:在数字选呼设置菜单中选择<打印设置>项，按【确认】键打开打印设置对话框,如图6.7.4所示。

b:旋转【CHANNEL】频道旋钮选择需要设置的呼叫类型，按【确认】键打开状态列表，可选择手动打印和自动打印。

打印设置		
发送的报警呼叫	:	手动
发送的其他呼叫	:	手动
接收的报警呼叫	:	手动
接收的其他呼叫	:	手动
< 返回 >		

图6.7.4

c:旋转【CHANNEL】频道旋钮选择要设置的打印模式，按【ENT】键确认。

d:按【CE】键返回到数字选呼设置菜单。

※打印机需接入RS-232接口，RS-232的通信速率需与打印机匹配。

◇ 频率转换设置

当设备收到普通呼叫时，设备允许用户设置通话频道的转换模式，分为自动转换和手动转换。设备默认是手动转换。

a:在数字选呼设置菜单中选择<频率转换设置>项，按【确认】键打开频率转换设置对话框,如图6.7.5所示。

b:旋转【CHANNEL】频道旋钮选择要设置的呼叫级别，按【确认】键打开转换模式列表，可选择手动或者自动。

c:旋转【CHANNEL】频道旋钮选择转换模式，按【确认】键确认。

d:按【取消】键返回到数字选呼设置菜单。

频率转换设置		
日常呼叫	:	自动
安全呼叫	:	自动
紧急呼叫	:	自动
< 返回 >		

图6.7.5

◇ 特殊呼叫设置

特殊呼叫包括中立船呼叫和医疗船呼叫，设备默认特殊呼叫是禁止发送的，用户可在该菜单项中使能特殊呼叫。

a:在数字选呼设置菜单中选择<特殊呼叫设置>项，按【确认】键打开特殊呼叫设置对话框，如图6.7.6所示。

b:旋转【CHANNEL】频道旋钮选择要设置的呼叫类型，按【确认】键打开特殊呼叫状态列表，可选择禁止或者使能。

c:旋转【CHANNEL】频道旋钮选择特殊呼叫的使能状态，按【确认】键确认。

d:按【取消】键返回到数字选呼设置菜单。

特殊呼叫设置		
中立船呼叫	:	禁止
医疗船呼叫	:	禁止
< 返回 >		

图6.7.6

◆ 清空存储器

当设备设置有误或者需要清除各类信息时，可以使用此功能。主菜单中<CLEAR FLASH>将清除用户所设置的所有信息，包括菜单项设置、用户频道的频率和通讯录信息。

a:在主菜单中选择<清空存储器>项，按【确认】键打开恢复出厂设置对话框。

b:旋转【CHANNEL】频道旋钮选择<确认>项，按【确认】键将清除存储器上所有的用户信息。

c:按【取消】键返回主菜单。

◆ 自检测试

设备具有自检功能，检测设备的接收，发射，DSC和存储器的工作状态是否正确。

a:在主菜单中选择<自检测试>项，按【确认】键打开自检测试对话框，设备开始进行自检。

b:待自检完成后，按【确认】键或者【取消】键返回主菜单。

◆ 服务信息

显示设备的机器编号，当前的硬件版本信息和软件版本信息，出厂日期。

a:在主菜单中选择<服务信息>项，按【确认】键打开服务信息对话框。

b:按【取消】键返回主菜单。

GNSS设备连接

FT-1100的GNSS接口可连接带有RS232或者RS422输出的GNSS接收机，通信速率可选，详见菜单操作，FT-1100接收的GNSS数据格式为NMEA0183 version 2.0中的RMC,GGA,GLL,ZDA,GNS语句。

当设备正确连接到了GNSS设备并且接收到有效的GNSS信息时，屏幕显示“<自动输入>”，如果设备与GNSS设备连接中断30秒后，那么设备将保存最后接收的GPS信息，屏幕显示“<信号丢失30秒>”。

设备的GNSS信息如果在4小时内没有得到更新，那么设备屏幕显示“<信号丢失4小时>”，并且会发出警告提示框，如图7.1所示，按【取消】键关闭警告提示框。

设备的GNSS信息如果在23.5小时内没有得到更新，那么设备屏幕显示“<没有GNSS信息>”，并且会发出警告提示框，如图7.2所示，同时将设备的GNSS信息设置为默认的无效信息，按【取消】键关闭警告提示框。

※GNSS的无效信息为经纬度的数字全为9，UTC时间的数字全为8。



图7.1



图7.2

系统接口规格说明

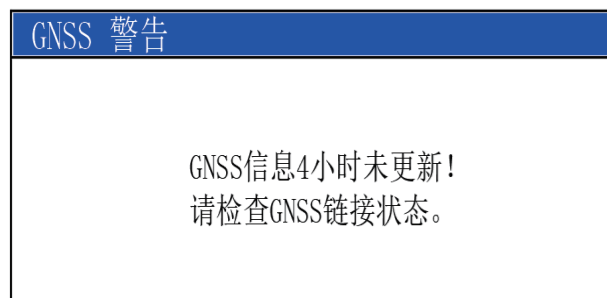
显示单元前视图说明

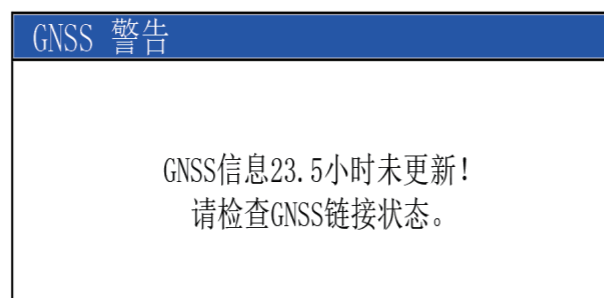
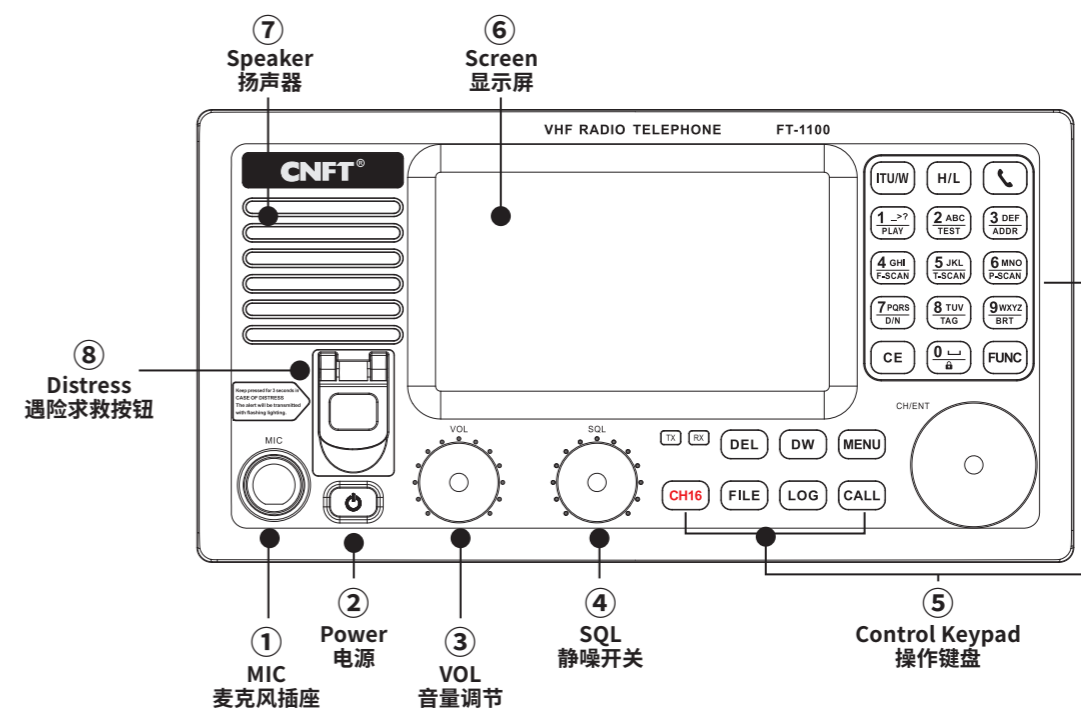

显示单元后视图说明

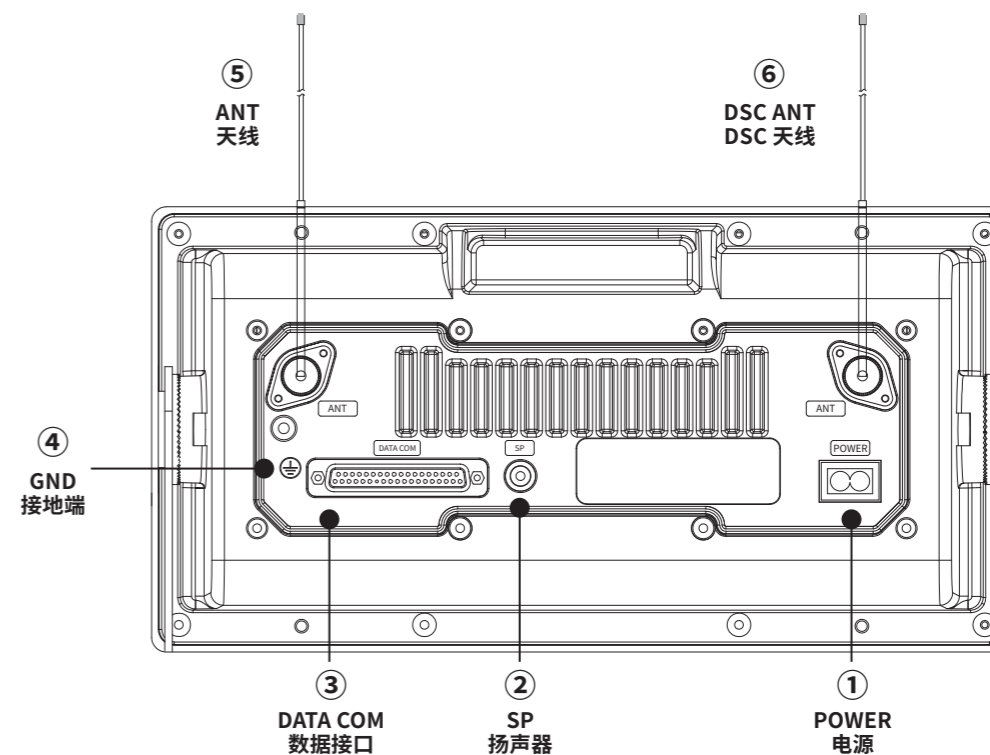

■ 显示单元后视图接口规格

① POWER(电源输入接口)

※注明：电源输入接口 (12V (10.8V-15.6V) DC:5A)

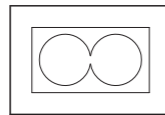

红色：电源输入端(+)
黑色：电源输入端(-)

② SP(3.5mm外接扬声器输出接口)

③ DATA COM(数据接口)

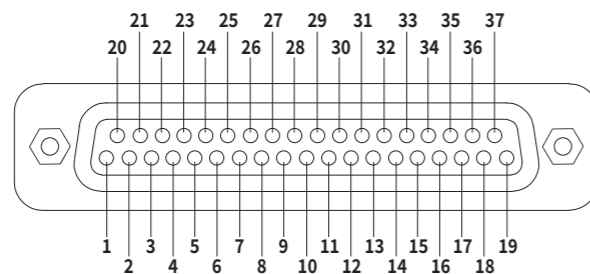

序号	定义	功能
1	GNSS+	定位数据输入
2	GNSS-	定位数据输入-
3	3.3V	3.3V电源输出
4	GND	内部接地
5	RX232_RXD	RS-232接收端
6	RX232_TXD	RS-232发送端
7	EXP_ALARM_L+	外部报警接口(低电平有效)
8	EXP_ALARM_L-	外部报警接口(低电平有效)
9	RS422_RXD+	RS-422接收端+
10	RS422_RXD-	RS-422接收端-
11	RS422_TXD-	RS-422接收端-
12	RS422_TXD+	RS-422接收端-
13	EXP_ALARM_H+	外部报警接口(高电平有效)

序号	定义	功能
14	EXP_ALARM_H-	外部报警接口(高电平有效)
15	CAN_H	外部话机通信接口
16	CAN_L	外部话机通信接口
17	EXP_SP+	外部话机通信接口
18	EXP_MIC1	外部话机音频输出
19	EXP_MIC4	外部话机音频输出
20	GND	内部地线
21	VDR+	VDR设备接口
22	VDR+	VDR设备接口
23	VDR-	VDR设备接口
24	VDR-	VDR设备接口
25	RELAY2	外部话机控制2
26	DI0	控制程序更新接口
27	CLK	控制程序更新接口
28	RST	控制程序更新接口
29	RELAY3	外部话机控制3
30	USB_DM	操作程序更新接口
31	USB_DP	操作程序更新接口
32	B00T0	操作程序更新接口
33	B00T1	操作程序更新接口
34	GND	内部地线
35	GND	内部地线
36	13.8V	13.8V输出
37	13.8V	13.8V输出

④ GND(整机接地端口)

⑤ ANT(RX/TX ANT接收和发射天线)

⑥ DSC ANT(DSC值守天线接口)

附录

◆ 附录A: 美国频段频率表 (USA)

频道号	频率 (MHZ)		频道号	频率 (MHZ)	
	发射频率	接收频率		发射频率	接收频率
1001	156.050	156.050	60		
2			61		
3			62		
4			1063	156.175	156.175
1005	156.250	156.250	64		
6	156.300	156.300	1065	156.275	156.275
1007	156.350	156.350	1066	156.325	156.325
8	156.400	156.400	67 *L	156.375	156.375
9	156.450	156.450	68	156.425	156.425
10	156.500	156.500	69	156.475	156.475
11	156.550	156.550	70 *D	156.525	156.525
12	156.600	156.600	71 *L	156.575	156.575
13 *L	156.650	156.650	72	156.625	156.625
14	156.700	156.700	73	156.675	156.675
15	*RX only	156.750	74	156.725	156.725
16	156.800	156.800	75		
17 *L	156.850	156.850	76		
1018	156.900	156.900	77 *L	156.875	156.875
1019	156.950	156.950	1078	156.925	156.925
20	157.000	161.600	1079	156.975	156.975
1020	157.000	157.000	1080	157.025	157.025
1021	157.050	157.050	1081	157.075	157.075
1022	157.100	157.100	1082	157.125	157.125
1023	157.150	157.150	1083	157.175	157.175
24	157.200	161.800	84	157.225	161.825
25	157.250	161.850	85	157.275	161.875
26	157.300	161.900	86	157.325	161.925
27	157.350	161.950	87	157.375	157.375
28	157.400	162.000	88	157.425	157.425

* L:仅低功率 * D:DSC频段 *RX only:禁止发射

◆ 附录B: 国际频段频率表 (INT)

频道号	频率 (MHZ)		频道号	频率 (MHZ)	
	发射频率	接收频率		发射频率	接收频率
1	156.050	160.650	60	156.025	160.625
2	156.100	160.700	61	156.075	160.675
3	156.150	160.750	62	156.125	160.725
4	156.200	160.800	63	156.175	160.775
5	156.250	160.850	64	156.225	160.825
6	156.300	156.300	65	156.275	160.875
7	156.350	160.950	66	156.325	160.925
8	156.400	156.400	67	156.375	156.375
9	156.450	156.450	68	156.425	156.425
10	156.500	156.500	69	156.475	156.475
11	156.550	156.550	70 *D	156.525	156.525
12	156.600	156.600	71	156.575	156.575
13	156.650	156.650	72	156.625	156.625
14	156.700	156.700	73	156.675	156.675
15 *L	156.750	156.750	74	156.725	156.725
16	156.800	156.800	75 *L	156.775	156.775
17 *L	156.850	156.850	76 *L	156.825	156.825
18	156.900	161.500	77	156.875	156.875
19	156.950	161.550	78	156.925	161.525
1019	156.950	156.950	1078	156.925	156.925
2019	*RX only	161.550	2078	*RX only	161.525
20	157.000	161.600	79	156.975	161.575
1020	157.000	157.000	1079	156.975	156.975
2020	*RX only	161.600	2079	RX only	161.575
21	157.050	161.650	80	157.025	161.625
22	157.100	161.700	81	157.075	161.675
23	157.150	161.750	82	157.125	161.725
24	157.200	161.800	83	157.175	161.775
25	157.250	161.850	84	157.225	161.825
26	157.300	161.900	85	157.275	161.875
			86	157.325	161.925
1027	157.350	157.350	87	157.375	157.375
1028	157.400	157.400	88	157.425	157.425

* L:仅低功率 * D:DSC频段 *RX only:禁止发射

◆ 附录C: 加拿大频段频率表 (CAN)

频道号	频率 (MHZ)		频道号	频率 (MHZ)	
	发射频率	接收频率		发射频率	接收频率
1001	156.050	156.050	60		
2			61		
3			62		
4			1063	156.175	156.175
1005	156.250	156.250	64		
6	156.300	156.300	1065	156.275	156.275
1007	156.350	156.350	1066	156.325	156.325
8	156.400	156.400	67 *L	156.375	156.375
9	156.450	156.450	68	156.425	156.425
10	156.500	156.500	69	156.475	156.475
11	156.550	156.550	70 *D	156.525	156.525
12	156.600	156.600	71 *L	156.575	156.575
13 *L	156.650	156.650	72	156.625	156.625
14	156.700	156.700	73	156.675	156.675
15	*RX only	156.750	74	156.725	156.725
16	156.800	156.800	75		
17 *L	156.850	156.850	76		
1018	156.900	156.900	77 *L	156.875	156.875
1019	156.950	156.950	1078	156.925	156.925
20	157.000	161.600	1079	156.975	156.975
1020	157.000	157.000	1080	157.025	157.025
1021	157.050	157.050	1081	157.075	157.075
1022	157.100	157.100	1082	157.125	157.125
1023	157.150	157.150	1083	157.175	157.175
24	157.200	161.800	84	157.225	161.825
25	157.250	161.850	85	157.275	161.875
26	157.300	161.900	86	157.325	161.925
27	157.350	161.950	87	157.375	157.375
28	157.400	162.000	88	157.425	

* L:仅低功率 * D:DSC频段 *RX only:禁止发射 *CH20xx等同于CHxxB

◆ 附录D: 天气频段频率表 (WX)

频道号	频率 (MHZ)	
	发射频率	接收频率
01	*RX only	162.550
02	*RX only	162.400
03	*RX only	162.475
04	*RX only	162.425
05	*RX only	162.450
06	*RX only	162.500
07	*RX only	162.525
08	*RX only	161.650
09	*RX only	161.775
10	*RX only	163.275
11	*RX only	149.225
12	*RX only	149.850
13	*RX only	160.650

*RX only:禁止发射

设备维护

现象	可能原因	排除方法
无法开机	电源接反;电源线未插紧; 设备输入电压超压	检查电源连接方向,重新正确连接; 插紧电源线; 确认设备输入电压在设备工作电压范围内
发射功率不足	天线安装不到位,如松动、角度偏差; 周围有遮挡物影响信号	重新安装天线,确保稳固且角度合适; 移除天线周围的遮挡物
接收信号弱或无信号	天线未正确连接; 天线被异物缠绕	检查天线连接部位,重新连接; 清理天线周围的异物
通信杂音大	设备未接地; 附近有干扰源,如其他电器设备	为设备正确接地; 将设备远离干扰源

◇ 定期检查

请定期对仪器进行以下必要项目的检查,这将有助于仪器保持良好的性能。

项目	现象	操作方法
电源电缆	暴露、破损	更换
电源插头	松动	插紧
显示部件	腐蚀	清洁
供电电压	过压、欠压	检查供电系统

◇ 整机的清洁

仪器表面的灰尘和污渍可以用软布擦除,如果必要,也可以用湿润的软布进行清洁。擦拭液晶表面时,请特别注意,因为它容易被擦伤。不要使用化学清洁剂,因为它们可能会把仪器表面的漆或标记擦掉。